

ICE ROBOTICS

www.icecobotics.com

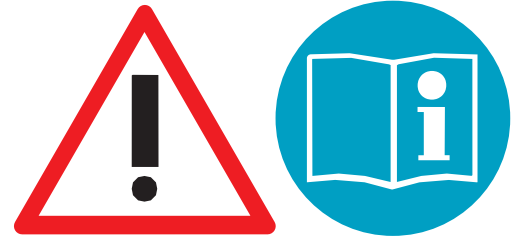

Operator & Parts Manual

Automatic Scrubber



i28BT
i28BT-CY
i32BT

8210060
REV.08 (01-2025)



READ OPERATOR MANUAL CAREFULLY!

IMPORTANT: To ensure full warranty protection, please fill out & return your warranty card.

Please fill out at time of installation for future reference.

Model No. _____

Serial No. _____

Machine Options _____

Sales Rep. _____

Sales Rep. Phone No. _____

Customer ID Number _____

Installation Date _____

HOW TO ORDER PARTS

Only use ICE Company supplied or equivalent parts. Parts and supplies may be ordered online, by phone, by fax or by mail.

1. Identify the machine model.
2. Identify the machine serial number from the data label.
3. Ensure the proper serial number is used from the parts list.
4. Identify the part number and quantity.
Do not order by page or reference numbers.
5. Provide your name, company name, customer ID number, billing and shipping address, phone number and purchase order number.



PROTECT THE ENVIRONMENT

Please dispose of packaging materials, old machine components such as batteries, hazardous fluids, including antifreeze and oil, in an environmentally safe way according to local waste disposal regulations.



Always remember to recycle.

ICE Cobotics (GuangDdong) Company Limited

XiangShi Road LiaoBu DongGuan GuangDong China

Tel: 0769 - 81869000

Fax: 0769 - 81863000

Specifications and parts are subject to change without notice.

TABLE OF CONTENTS

SAFETY PRECAUTIONS.....	4
MACHINE COMPONENTS.....	5
MACHINE SETUP & INSTALLATION.....	6
MACHINE OPERATION.....	7
WHILE OPERATING MACHINE.....	7
TANK DRAINING.....	8
BATTERY CHARGING.....	9
PREVENTATIVE MAINTENANCE.....	9
CYLINDRICAL BRUSH MODEL.....	11
CLINDRICAL ASSEMBLY INSTRUCTIONS.....	12
BASIC TROUBLESHOOTING.....	14
TECHNICAL SPECIFICATION.....	15
PARTS LIST.....	16-45
WEAR AND TEAR PARTS.....	44
WIRING DIAGRAM.....	45

SAFETY PRECAUTIONS

This machine is intended for commercial use. It is designed exclusively to scrub hard floors in an indoor environment and is not constructed for any other use. Only use recommended accessories.

All operators shall read, understand and exercise the following safety precautions:

1. Do not operate machine:

- Unless trained and authorized.
- Unless you have read and understand the operators manual.
- In flammable or explosive areas.
- If not in proper operating condition.
- In outdoors areas.

2. Before starting machine:

- Make sure all safety devices are in place and operate properly.

3. When using machine:

- Go slow on inclines and slippery surfaces.
- Follow all safety guidelines.
- Be very careful when using the machine in reverse.
- Reduce speed when turning.
- Report and fix any damage to machine prior to operating it.
- Never allow children to play on or around.
- Do not operate on inclines that exceed 5% (3°).

4. Before leaving or servicing machine:

- Stop on level surface.
- Turn off machine.

5. When servicing machine:

- Read operators manual thoroughly prior to operating or servicing this machine.
- Use manufacturer supplied or approved replacement parts.
- Secure machine with wheel blocks prior to jacking the machine up.
- Use approved jack or hoist to safely elevate the machine.
- Disconnect batteries prior to working on machine.
- Wear gloves when handling batteries or battery cables.

- Avoid any contact with battery acid
- Avoid moving parts. Do not wear loose fitting clothing while servicing machine.



WARNING: Batteries emit hydrogen gas. Explosion or fire can result from hydrogen gas. Keep sparks and open flames away! Keep battery compartment open when charging.



WARNING: Flammable materials can cause an explosion or fire. Do not use flammable materials in tanks.



WARNING: Flammable materials or reactive metals can cause explosion or fire. Do not pick up.

MACHINE COMPONENTS

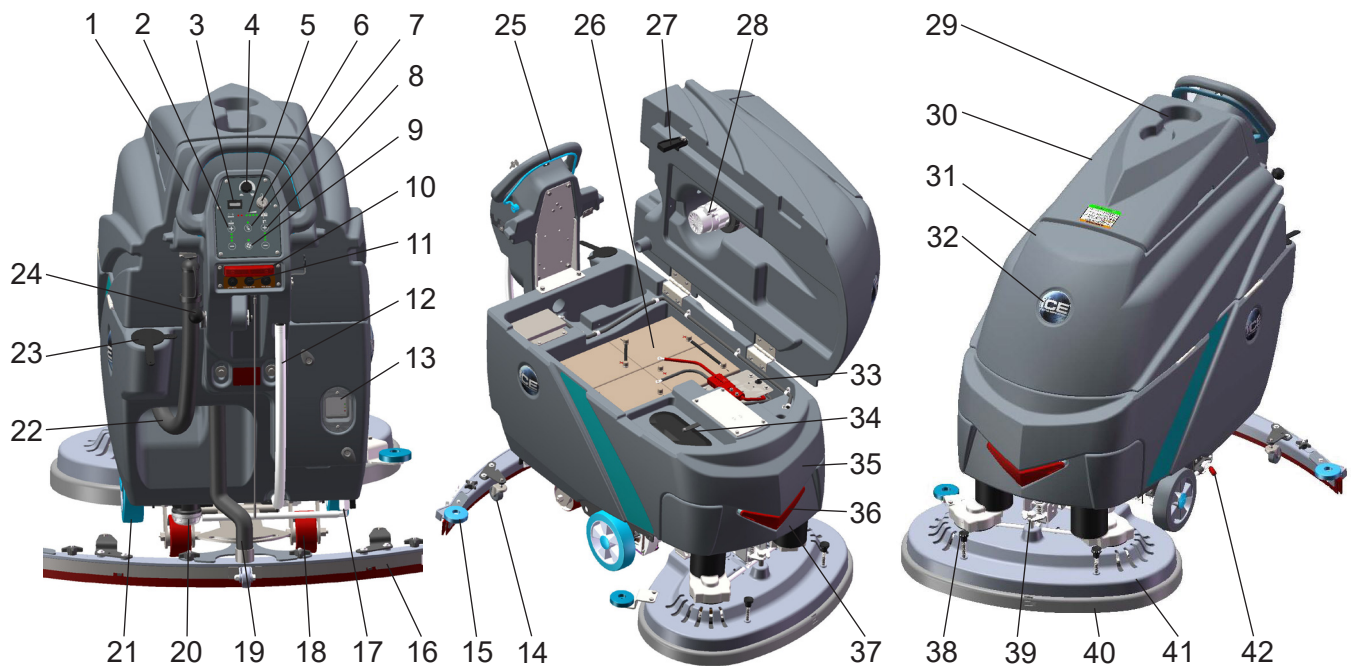

1. Control Handle
2. Brush pressure adjusting buttons & indicator light
 - + Brush pressure increase button
 - Brush pressure decrease button
3. Hour meter
4. Speed Control Knob
 - Slow Speed
 - Fast Speed
5. Battery Meter
6. Main Power Key Switch
7. 1-STEP scrub head up/down switch & indicator light
8. Solution flow Control Buttons & Indicator Light
 - + Solution flow Increase button
 - Solution flow Decrease button
9. Vacuum Motor Switch & Indicator Light
10. Emergency stop button
11. Drive motor circuit breaker
12. Solution Tank Level / Drain Hose
13. On-board battery charger
14. Caster, 2Inch, Squeegee Adjustment
15. Bumper Rollers
16. Squeegee Assembly
17. Ball Valve
18. Casters, 4 Inch
19. Squeegee Vacuum Hose
20. Filter Assembly
21. Wheels, 8 Inch
22. Recovery Tank Drain Hose
23. Hose fill-port
24. Squeegee Lift Lever
25. Control Handle Start Bail
 - Direction Decal
26. Batteries
27. Recovery Tank Support Stand
28. Vacuum Motor, 24VDC
29. Cup Holder
30. Recovery Tank Cover
31. Recovery Tank
32. ICE Logo
33. Vacuum motor circuit breaker
34. Bucket Fill Port/ Clean-Out Port
35. Solution Tank
36. LED Light
37. Front cover
38. Brush & Pad release plunger
39. Scrub Head adjusting bolt
40. Scrub Head Skirt
41. Scrub Head Assembly
42. Parking Brake (Option)

MACHINE SET UP & INSTALLATION

UNCRATING MACHINE

Be sure and check packing carton for any damage. Immediately report any damage to carrier. Check the contents of package to ensure that the following items are included:

- Machine
- 4-6V Batteries
- Squeegee assembly
- 2-Pad Drivers
- 2-Brushes

INSTALLING BATTERIES

The batteries are already in the machine upon delivery; However you will need to connect the cables to the battery posts.

⚠ WARNING: Batteries emit hydrogen gas. Explosion or fire can result from hydrogen gas. Keep sparks and open flames away! Keep battery compartment open when charging.

Recommended Battery spec:
4-6V, 260AH@20HR deep cycle batteries.
Max. batteries dimensions :
265mm (L) X 190mm (W) X 280mm (H)

1. Turn the main power key switch off.
2. Open recovery tank to gain access to battery compartment.
3. Carefully place the batteries into the compartment as shown in figure below. Place the battery brace at the rear of the batteries.
DO NOT DROP BATTERIES INTO COMPARTMENT!
4. Connect battery cables to posts in numbered order as shown in drawing below.
RED to POSITIVE and BLACK to NEGATIVE.

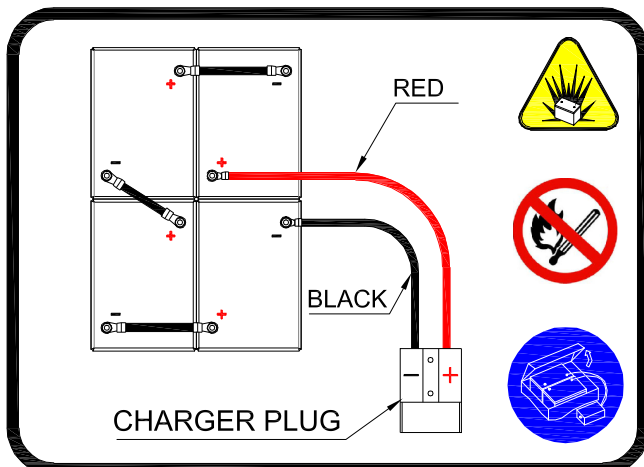

MACHINE SET UP

PRE-OPERATION CHECKS

1. Sweep or dust mop the surface to be cleaned.
2. Check battery meter to make sure batteries are fully charged. (See BATTERY CHARGING)
3. Check that squeegee is properly installed.
4. Check that brushes / pads is properly installed.

INSTALLING BRUSHES OR PADS

1. Turn off the 1-STEP Scrub head up/down switch (see machine components, item #7) and Raise the Scrub head off the floor, then stop machine on the level surface, remove the key and ensure the machine is turned off.
2. If using the Pad Driver, first attach the appropriate pad to the pad driver surface.
3. Align the pad driver or brush under the motor hub and push it upward to engage.



4. To remove the pad driver or brush, raise the scrub head and push the pad release plunger (see machine components, item #38) downward.

MOUNTING THE SQUEEGEE ASSEMBLY

1. Lift the squeegee lift lever (see machine components, item #24) to the upward position.
2. Mount the squeegee assembly to the squeegee pivot bracket. make sure the knobs are completely seated into the slots before securing knobs.
3. Connect the vacuum hose to the squeegee assembly. Loop the hose by using the hose clip provided.
4. Check the squeegee blades for proper adjustment.

FILLING THE SOLUTION TANK

The machine is equipped with a hose fill-port (see machine components, item #23) at the rear of the machine, and a bucket fill-port (see machine components, item #34) located under the recovery tank. Before accessing the bucket fill-port make sure that the recovery tank is empty.

Fill the solution tank to the "100L" level on the solution tank sight gauge. When using the bucket fill-port, stop filling when the level reaches the bottom edge of the fill-port.

NOTE: When filling the solution tank with a bucket, make sure that the bucket is clean. Do not use the same bucket for filling and draining the machine.

 **WARNING:** Do not put any flammable materials into solution tank. this can cause an explosion or a fire. Only use recommended cleaning chemicals. Contact your janitorial supply distributor for recommendations on proper chemicals.

MACHINE OPERATION

 **WARNING:** Do not operate machine unless you have read and understand this manual.

1. Turn the main power key switch(see machine components, item #6) to the on (I) position.
2. Check the battery level meter (see machine components, item #5), if the battery meter is in the red, **DO NOT** continue to operate the machine and recharge the batteries immediately.
3. Turn on the 1-STEP scrub head up/down switch (see machine components, #7) to lower the scrub head to the floor, the 1-STEP switch indicator is light.
4. Lower squeegee assembly to the floor by lowering the squeegee lift lever(see machine components, item #24).
5. Check the solution flow indicator (see machine components, item #8), adjust the solution flow control switch to a desired flow rate.

NOTE: Solution will not begin to flow until the control handle bail is pulled.

6. Turn on the vacuum motor switch(see machine components, item #9).
7. Pull the control handle bail (see machine components, item #25) backwards to start scrubbing .The machine will automatically propel forward. To reverse the machine, simply push the control handle bail forward.
NOTE: Raise squeegee when reversing machine.
8. The scrubbing speed can be adjusted, Adjust the speed control knob (see machine components, item #4) to a desired speed.
NOTE: 45-60 meters (150-200 ft)per minute is the recommended scrubbing speed.
9. simply press the pressure adjuting button to increase (+) or decrease (-) the brush pressure as needed.
10. To stop scrubbing, release the control handle bail, turn off the 1-STPE switch to raise the scrub head assembly, raise he squeegee assembly.

WHILE OPERATING MACHINE

 **WARNING:** Fire Or Explosion Hazard. Do Not Pick Up Flammable Materials Or Reactive Metals.

1. Go slow on inclines and slippery surfaces. Do not operate the machine on inclines that exceed 5% (3°).
2. Do not keep the machine in the same position with pad / brush spinning, keep the machine moving to prevent damage to floor finish.
3. If the squeegee assembly leaves streaks on the floor, raise the squeegee off the floor and wipe the blades down with a damp cloth. Pre-sweep the area to prevent leaving streaks on the floor.
4. Pour a recommended defoamer into the recovery tank if excessive foam appears.

 **WARNING:** Do not allow foam to enter the float shut-off screen, vacuum motor damage will result. Foam will not activate the float shut-off screen.

5. Occasionally check the battery level meter(see machine components, item #5). when meter is in the red, stop scrubbing and recharge the batteries.

 **WARNING:** When battery meter is in the red, do not continue to operate the machine. Battery damage may result.

6. When the solution tank runs empty, press the 1-STEP switch raise the brush head. Keep the squeegee down and continue to vacuum until all the dirty water is picked up.

NOTE: *Brush motors will not work when the scrub head assembly raised.*

NOTE: See **TANK DRAINING** section to learn how to drain recovery and solution tanks.

CIRCUIT BREAKER / FUSES

The machine is equipped with 2 resettable circuit breakers(see machine components, item #11, item# 33) to protect the drive motor and the vacuum motor from damage. If the circuit breakers should trip, it can't be reset immediately. You must first determine what caused the breaker to trip, and allow the motor to cool down and then you can manually reset the circuit breakers.

The machine is also equipped with a 60A fuse to protect the brush motors from damage. When replacing a fuse never substitute a higher Amps rated fuse than specified.

HOURLY METER

The hour meter (see machine components, item #3) records the number of total hours the brush motor has been powered on. Use the hour meter to determine when to perform recommended maintenance procedures and to record service history.

EMERGENCY STOP BUTTON/ BRAKE

The machine is equipped with an Electromagnetic Brake Mechanism on the Transaxle. When in case of Emergency, release the Control Handle bail(see machine components, item #25) or strike the Emergency stop button (see machine components, item #10), the machine will be braked and then stop. Reset the emergency stop button, turn on the Main power key switch, and then pull the control handle bail, the machine will be restart.

NOTE: *The machine can not be moved unless the Main Power Key Switch and the Control Handle bail be turned on.*



WARNING: Do Not Change the Default Settings of the Electromagnetic Brake Mechanism unless Authorized, otherwise it may cause Machine Damage or Personal Injury. Contact the Authorized Service center for machine repairs.

TANK DRAINING

1. Turn the machine off.
2. With the squeegee and scrub head in their "up" position, transport machine to approved area for draining tank(s).

DRAINING THE RECOVERY TANK

Any time scrubbing is completed, or when refilling solution tank, the recovery tank should be drained and cleaned.

! WARNING: If the recovery tank is not drained when the solution tank has been refilled, foam or water may enter the float shut-off screen and cause damage to the vacuum motor.

1. While holding the drain hose (see machine components, item #22) upward, remove the cap and lower hose to drain.
2. Open the recovery tank cover and rinse out the tank. Use a rag to remove any excess dirt.
3. Clean the float shut-off screen and debris tray located in the recovery tank .

DRAINING THE SOLUTION TANK

Any time scrubbing operation is completed, the solution tank should be drained and cleaned.

1. Pull the solution tank level hose(see machine components, item #12) off the hose fitting, this will allow the solution to flow freely into a bucket or floor drain.
2. Remove the cover of the filter assembly(see machine components, item #20) to drain the solution tank, check the filter screen and clean up it if necessary.
3. Rinse the solution tank with clean water after every use. This will help prevent chemical buildup and clogging of the solution lines.
4. After rinsing out the tank, securely reconnect the tank level hose to the hose fitting, replace the filter assembly cover and be sure the filter screen and the "O" ring is in the correct position.

BATTERY CHARGING



WARNING: Fire Or Explosion Hazard.

Batteries Emit Hydrogen Gas. Keep Sparks and Open Flame Away. Keep Battery Compartment Propped Open When Charging.

NOTE: Use only approved chargers with the following specifications:

- Automatic shut off circuit
- Deep cycle charging
- Output current of 20-30 Amps
- Output voltage of 24 volts

ON-BOARD BATTERY CHARGER

As standard configuration, the machine is equipped with the On-board battery charger (see machine components, item #13). The settings of On-board battery charger had been set for the recommended batteries type.



WARNING: The On-board battery charger setting's change are to be completed by authorized service centers only. Failure to properly set will result in the batteries or charger damage.

1. Transport the machine to a well ventilated area.
2. Turn the machine off.
3. If charging wet (lead acid) batteries check the fluid level before charging.
4. Prop up the recovery tank by the support stand (see machine components, item #27) for ventilation.
5. Connect the charger's AC power supply cord to a properly grounded receptable.
6. The charger will automatically begin to charge, once the charging cycle begins, the indicator lights will progress from red, yellow to green. when the green indicator light comes on, the charging cycle is done. Unplug the charger cord.

NOTE: The machine will can not operate when charging.

OFF-BOARD BATTERY CHARGER (OPTION)

1. Place charger and machine in a well ventilated area.
2. Turn the machine off.

3. If charging wet (lead acid) batteries check the fluid level before charging.
4. Prop up the recovery tank by the support stand (see machine components, item #27) for ventilation.
5. Connect the charger's AC power supply cord to a properly grounded receptable.
6. Connect the charger's DC cord into the machine's battery receptacle at the rear of the machine.
7. The charger will automatically begin to charge and will automatically shut off once the batteries are fully charged.
8. Upon completion of charging, disconnect the AC power supply cord first, and then disconnect the charger from the machine.

PREVENTATIVE MAINTENANCE



WARNING: Before performing any maintenance on the machine, be sure that the power is turned off, or the batteries are disconnected!



WARNING: Repairs are to be completed by Authorized service centers only. Any repairs completed by unauthorized persons will void the warrenty.

DAILY MAINTENANCE

1. Remove pad driver/ brush and clean with approved cleaner.
2. Drain recovery and solution tanks completely and rinse out with clean water. Visually check the recovery tank for debris and clean out as necessary.
3. Raise the squeegee assembly off floor and wipe it down with a damp towel. Be sure to store the squeegee in the up position.
4. Remove the float shut-off assembly and rinse it out with clean water.
5. Clean machine with an approved cleaner and a damp towel.
6. Recharge the batteries.
7. Check the condition of the squeegee blade wiping edge, rotate blade if worn.

MONTHLY MAINTENANCE

1. Clean the battery tops to prevent corrosion.
2. Check for loose battery cable connections.
3. Inspect and clean the recovery tank cover seal. Replace it if damaged.
4. Lubricate all grease points and pivot points with silicon spray and approved grease.
5. Check the machine for loose nuts and bolts.
6. Check the machine for leaks.
7. Battery must be stored in a charged state, please charge monthly.

MOTOR MAINTENANCE

1. Contact your local Distributor for any motor maintenance.
2. Motor should have the brushes checked every 250 hours. Brushes should be replaced when they are worn to a length of 10 mm or less.



BATTERY MAINTENANCE

WARNING: Batteries emit hydrogen gas and an explosion or fire can result. Keep sparks and fire away from batteries at all times.



WARNING: Whenever servicing batteries, be sure to wear protective gloves. Avoid contact with battery acid at all times.

NOTE: For the best machine performance, keep batteries charged at all times. Do not let them sit in a discharged condition.

1. Always follow the battery charging directions as outlined in the BATTERY CHARGING section of this manual.
2. Keep battery tops and terminals free from corrosion. A strong solution of baking soda and water is the best way to keep the batteries corrosion free. **DO NOT ALLOW THE BAKING SODA / WATER SOLUTION TO ENTER THE BATTERY CELLS.**
3. Use a wire brush with the baking soda solution to properly clean the battery posts and connections.
4. Check battery connections for wear and loose terminals. replace if necessary.

MACHINE STORAGE

1. Always store the machine indoors.
2. Always store the machine in a dry area.
3. Always store the machine in its upright position.
4. Always store the machine with the pad driver/brush raised off the floor.
5. Always store the machine with the squeegee assembly raised off the floor.
6. If storing in an area which may reach freezing temperatures, be sure to drain all fluids from the machine prior to storage. Any damage caused by freezing temperatures will not be covered by the warranty.
7. Drain the recovery tank.
8. Drain the solution tank of all fluid.

CYLINDRICAL BRUSH MODEL

INSTALL BRUSH

1. Raise scrub head off the floor and turn off the power.(remove key)
2. Remove brush door from scrub head by loosening the knob.
3. Attach brush door to the brush end that has the double row of bristles to install brush.
4. Check the brushes to ensure they are properly adjusted.

INSPECT THE BRUSH PATTERN

After installing a new set of cylindrical brushes check the brush pattern to ensure proper brush adjustment.

1. Measure the distance from the front edge of the scrub head to the floor and from the back edge of the scrub head to the floor. The measurements should be the same.
2. To level the scrub head, loosen the lock nut and turn the leveling screw clockwise to lower the rear of the scrub head or counter--clockwise to lower the front.

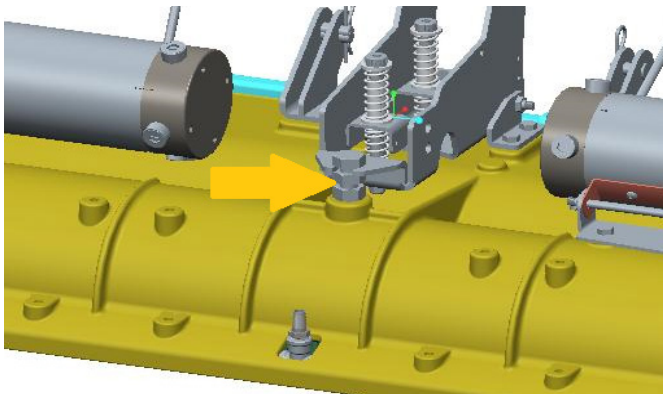

3. Position the machine on a dry dusty floor or apply a powdered substance, such as chalk.
4. Adjust the speed control knob to "zero" ()
5. Shut off the solution flow.
6. Pull the control handle bail to create a brush pattern on the floor.
7. Raise the scrub head and pull the machine away.
8. Observe the brush pattern on floor. If the brush pattern is uneven or tapered, adjustment is required.

Correct Brush Pattern



TO ADJUST A TAPPED BRUSH PATTERN

1. Remove the brush door from the brush.

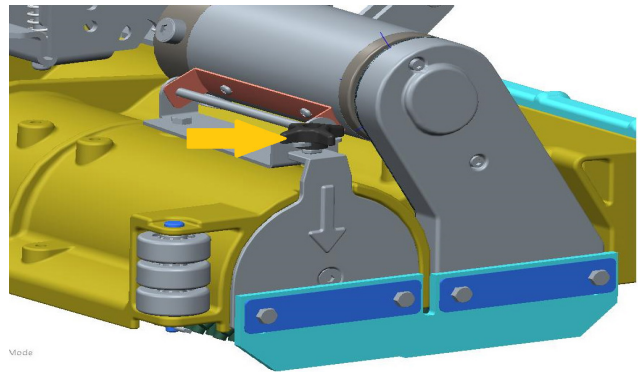

2. Hold the brush plug shaft with a wrench and loosen the 6mm hex screw.

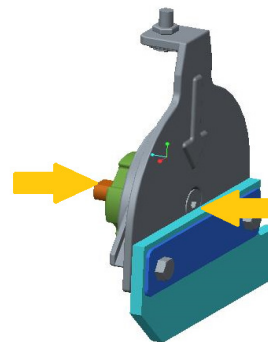

3. To lower the brush end, turn the shaft clockwise for the front brush and counter--clockwise for the rear brush. Retighten hex screw.
4. Recheck brush pattern.
NOTE: Replace brushes when worn to 5/8" (15mm).

Cylindrical Assembly Instructions

Lower scrub head to the ground, then turn off the power (remove key).

STEP#1: Remove Front Cover

1. Remove knob (2) from solution tank.
2. Disconnect cable (1) of the led light.
3. Remove front cover from solution tank

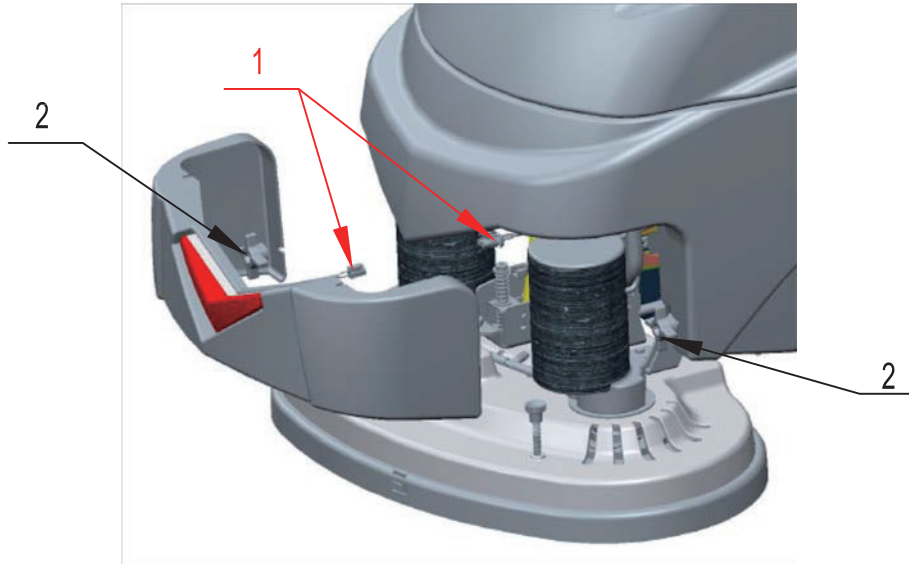

STEP#2: Remove Disc Scrub Head Assembly

1. Remove cotter pin and pins (5) from scrub head lift bracket, then remove cotter pin and pin (3) from spring bracket.
2. Remove lock nut and hex bolt (6) from roller guide (1).
3. Disconnect motor power cords (2).
4. Loosen clamp on the solenoid valve and remove tubing (4).
5. Remove scrub head assembly.

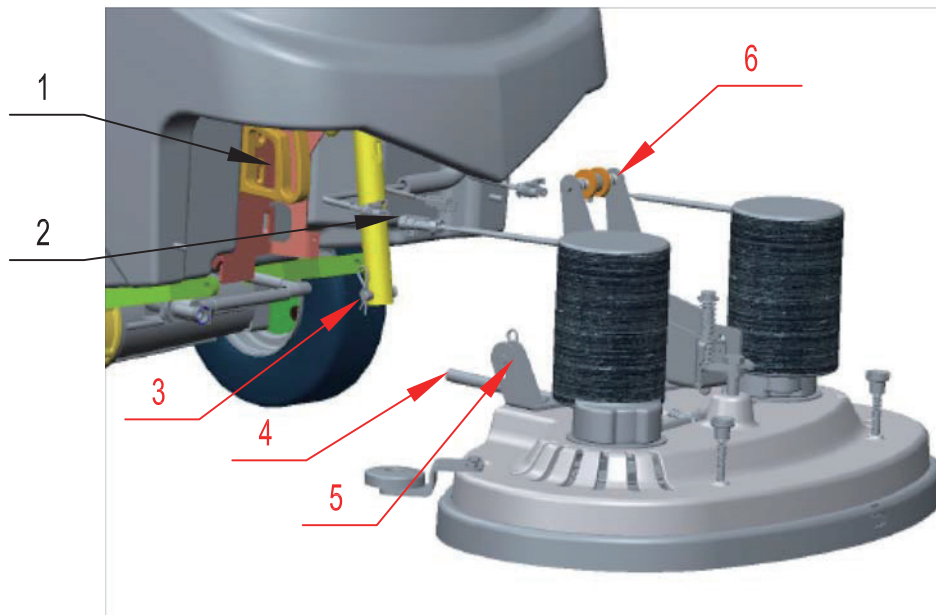

RECOVERY TANK GROUP

INSTRUCTION

STEP#3: Assembly Cylindrical Scrub Head Group

1. Adjust initial position of sleeve nut(10) on the actuator(1) to right place(L) by rotating manually.
2. Place cylindrical scrub head under solution tank.
3. Connect tubing(3) and fasten clamp.
4. Insert pins into cylindrical scrub head lift bracket(4) through arm(9) installing on the frame, and place cotter pin into holes on the pin.
5. Insert pin into spring bracket(5) through sleeve nut installing on the actuator, and place cotter pin into holes on the pin(6).
6. Insert hex bolt into roller guide(8) through lifting bracket and fasten lock nut(2).
7. Connect motor power cords(7).

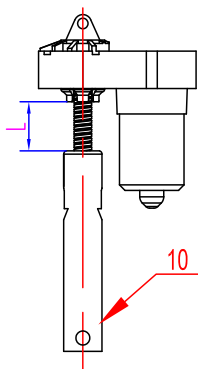

L=35±5MM

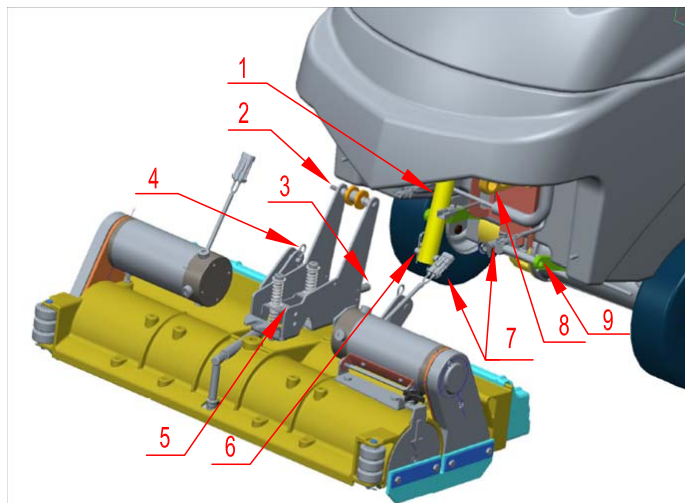

STEP#4: Assembly Front Cover

1. Connect cable of the led light(3).
2. Install front cover through stud fixing(1) on solution tank.
3. Fasten the knobs(2).

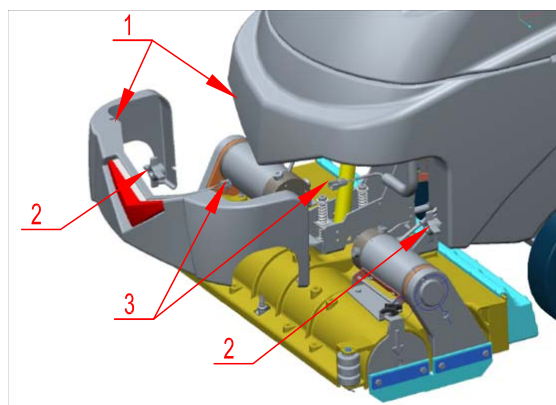

BASIC TROUBLESHOOTING

PROBLEM	CAUSE	SOLUTION
Machine will not operate	Control handle bail not pulled	Pull control handle bail
	Batteries need to be charged	Charge batteries
	Bad battery(s)	Replace battery(s)
	Loose battery cable	Tighten loose cable
	Emergency stop button activated	Reset Emergency stop button
	Main PCB fuse blown	Contact ICE service center
	Faulty key switch	Contact ICE service center
Brush motor will not operate	1-STEP scrub head up/down switch is off	Turn on the 1-STEP switch
	Battery meter lockout activated	Recharge batteries
	Brush motor fuse blown	Replace 60A fuse
	Brush motors over load	Turn on / off the 1-STEP switch
	Faulty control handle bail switch	Contact ICE service center
	Faulty brush motor or wiring	Contact ICE service center
	Worn Motor carbon brushes	Contact ICE service center
	Bad solenoid	Contact ICE service center
Machine does not propel	The Main Power Key Switch be Turned off, the Control handle bail not pulled	Turn on the Key switch, Pull the control handle bail
	Tripped drive motor circuit breaker	Reset drive motor circuit breaker button
	Faulty transaxle motor or wiring	Contact ICE service center
	Worn Motor carbon brushes	Contact ICE service center
Vacuum motor will not operate	Tripped vacuum motor circuit breaker	Reset vacuum circuit breaker button
	Faulty vacuum motor or wiring	Contact ICE service center
	Worn Motor carbon brushes	Contact ICE service center
Little or no solution flow	Ball valve set too low or shut off	Turn on the ball valve
	Solution flow control knob set too low or shut off	Adjust solution control flow knob
	Clogged solution tank filter or solution hose	Clean solution tank filter or flush out solution hose
	Clogged solution Solenoid valve	Remove valve and clean
Poor water pick up	Recovery tank is full	Drain recovery tank
	Loose drain hose cap	Tighten cap
	Clogged float shut-off screen located in recovery tank	clean screen
	Clogged squeegee assembly	Clean squeegee assembly
	Worn squeegee blades	Replace or rotate squeegee blades
	Incorrect squeegee blade deflection	Adjust squeegee blade height
	Loose vacuum hose connections	Secure hose connections
	Clogged vacuum hose	Remove clogged debris
	Damaged vacuum hose	Replace vacuum hose
	Recovery tank cover not in place	Properly position cover
	Damaged recovery tank cover seal	Replace seal
	Faulty vacuum motor	Contact ICE service center
Short run time	Low battery charge	Fully recharge batteries
	Defective batteries	Replace batteries
	Batteries need maintenance	See BATTERY MAINTENANCE
	Faulty battery charger	Repair or replace battery charger
	Down pressure lever is set for extra scrub head pressure	Lower down pressure lever

TECHNICAL SPECIFICATIONS

MODEL	i28BT-CY	i28BT	i32BT
DIMENSIONS - L	61.02 in / 1,550 mm		62.21 in / 1,580 mm
DIMENSIONS - W	30.51 in / 775 mm		34.06 in / 865 mm
DIMENSIONS - H	44.49 in / 1,130 mm		44.49 in / 1,130 mm
WEIGHT	352.74 lbs / 160 Kg		374.79 lbs / 170 Kg
WEIGHT WITH BATTERIES	661.39 lbs / 300 Kg		683.43 lbs / 310 Kg
SOLUTION TANK CAPACITY	26.42 Gal / 100 L		
RECOVERY TANK CAPACITY	31.7 Gal / 120 L		
SQUEEGEE WIDTH	Standard: 40.5 in / 1,030 mm Option: 44.5 in / 1,130 mm		Standard: 46.5 in / 1,185 mm Option: 44.5 in / 1,130 mm
CLEANING PATH WIDTH	28 in / 700 mm		32 in / 800 mm
PRODUCTIVITY RATE	30,667 ft ² / 2,850 m ² h		34,983 ft ² / 3,250 m ² h
DRIVE SYSTEM	Transaxle, 24VDC, 0.27 hp / 200 W		
TRAVEL SPEED, MAXIMUM	Cleaning: 65 m/Min 213.25 ft/min		Transporting: 72 m/Min 236.22 ft/Min
MINIMUM AISLE TURN	63 in / 1600 mm		
PAD/BRUSH PRESSURE	0 ~ 79.37 lbs 0 ~ 36 kg	39.68 lbs / 18 kg 79.37 lbs / 36 kg 119.05 lbs / 54 kg	
SOLUTION FLOW RATE	0 ~ 0.66 Gal / Min 0 ~ 2.5 L/Min		
BRUSH / CYLINDRICAL MOTORS	0.75 hp / 560W × 2, 750 RPM	0.75 hp / 550W × 2, 210 RPM	
BRUSH / CYLINDRICAL DIMENSIONS (x2)	Dia: 150 mm / 6 in Length: 700 mm / 28 in	Diameter: 355.6 mm / 14 in	Diameter: 406.4 mm / 16 in
VACUUM MOTOR	0.8 hp / 600 W		
WATER LIFT - AIR FLOW	65 in / 1650 mm		
BATTERIES	4 - 6V, 260 AH @ 20 Hr		
RUN TIME PER CHARGE	3.5~4 Hours		
VOLTAGE DC	24 V		
DECIBEL RATING AT OPERATOR'S EAR, INDOORS	68 dB(A)		
GRADE LEVEL, MAX	5% (3°)		

RECOVERY TANK GROUP

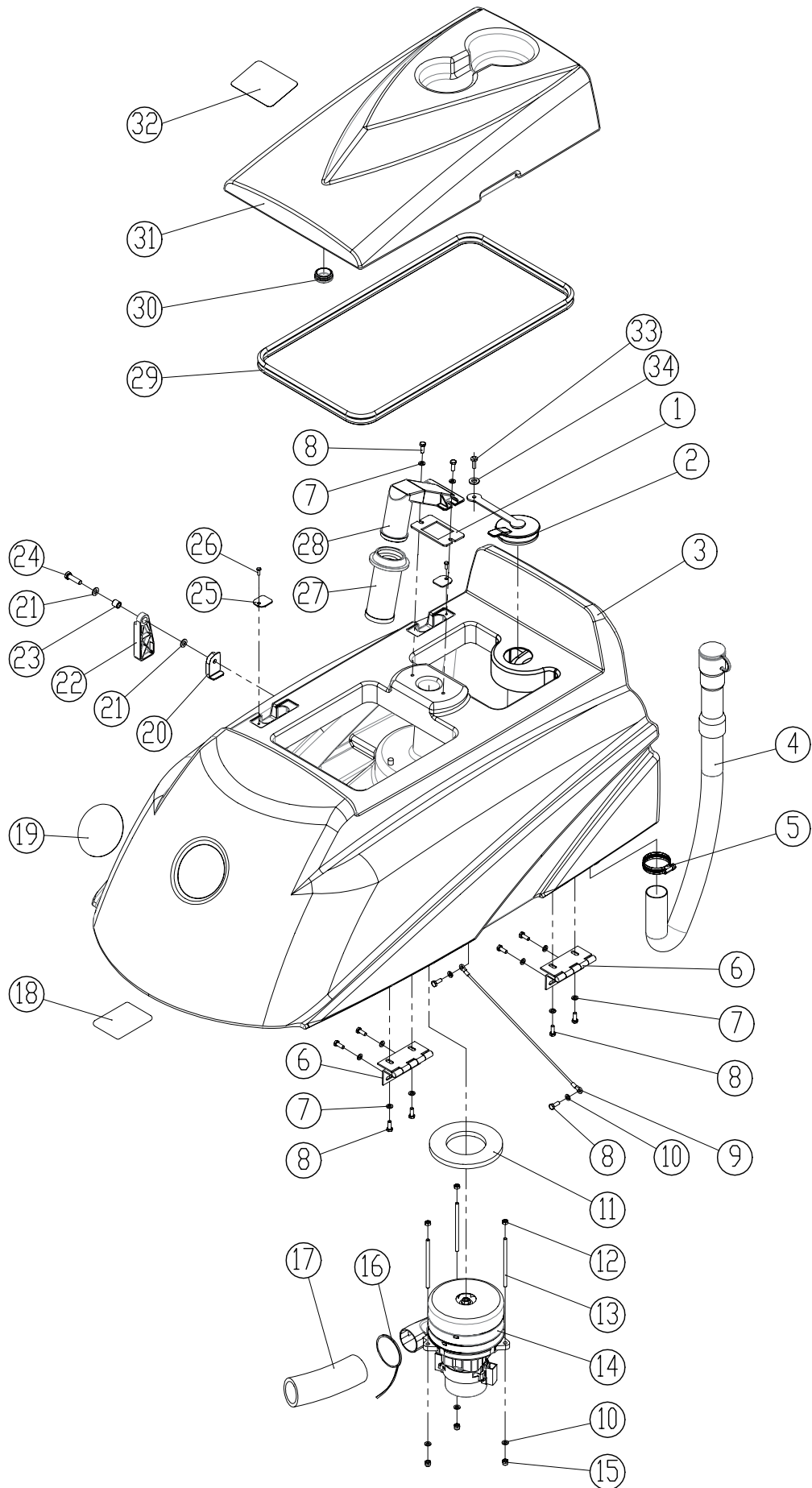

RECOVERY TANK GROUP

DIA NO.	PART NUMBER	DESCRIPTION	SERIAL NUMBER	NO REQ'D
1	8111001	GASKET		1
2	8131004	CAP	60018100496~	1
3	8210102	RECOVERY TANK		1
4	8131031	DRAIN HOSE	60018100496~	1
5	1962050	CLAMP		1
6	8111300	HINGE ASSEMBLY		2
7	1421618	FLAT WASHER M6×18×1.6		10
8	1021616	HEX BOLT M6 X 16		12
9	8210207	CABLE		1
10	1421612	FLAT WASHER M6×12×1.6		5
11	8112005	GASKET, VACUUM MOTOR		1
12	1121605	HEX NUT M6		3
13	8210209	STUD M6×110		3
14	8210260	AMETEK VACUUM MOTOR 24VDC, KIT		1
	8132006	CARBON BRUSH, VACUUM MOTOR		2
15	1123608	LOCK NUT M6		3
16	1914300	TIE, NYLON, 5X300		1
17	8132007	MUFFLER, VACUUM MOTOR		1
18	8210230	LABEL, BATTERY INSTALLATION		1
19	4010316	ICE LOGO		1
20	8111008	BRACKET		1
21	1421816	FLAT WASHER M8×16×1.6		2
22	8111007	RECOVERY TANK SUPPORT		1
23	8115404	SLEEVE, P/M		1
24	1021830	HEX BOLT M8×30		1
25	8111016	PLATE		2
26	1221512	SCREW M5×12		2
27	8111015	FLOAT, SHUT-OFF		1
28	8111014	FLOAT ADAPTER		1
29	8210201	RECOVERY TANK COVER SEAL		1
30	8011005	CAP		1
31	8210103	RECOVERY TANK COVER		1
32	8111022	WARNING LABEL		1
33	1321110	SELF-TAPPING SCREW ST3.5 ×10		1
34	1421409	FLAT WASHER M4× ϕ 9×0.8		1

Note:

NO 2、32、33: Design improvement,the new design can fit old machine.

SOLUTION TANK GROUP

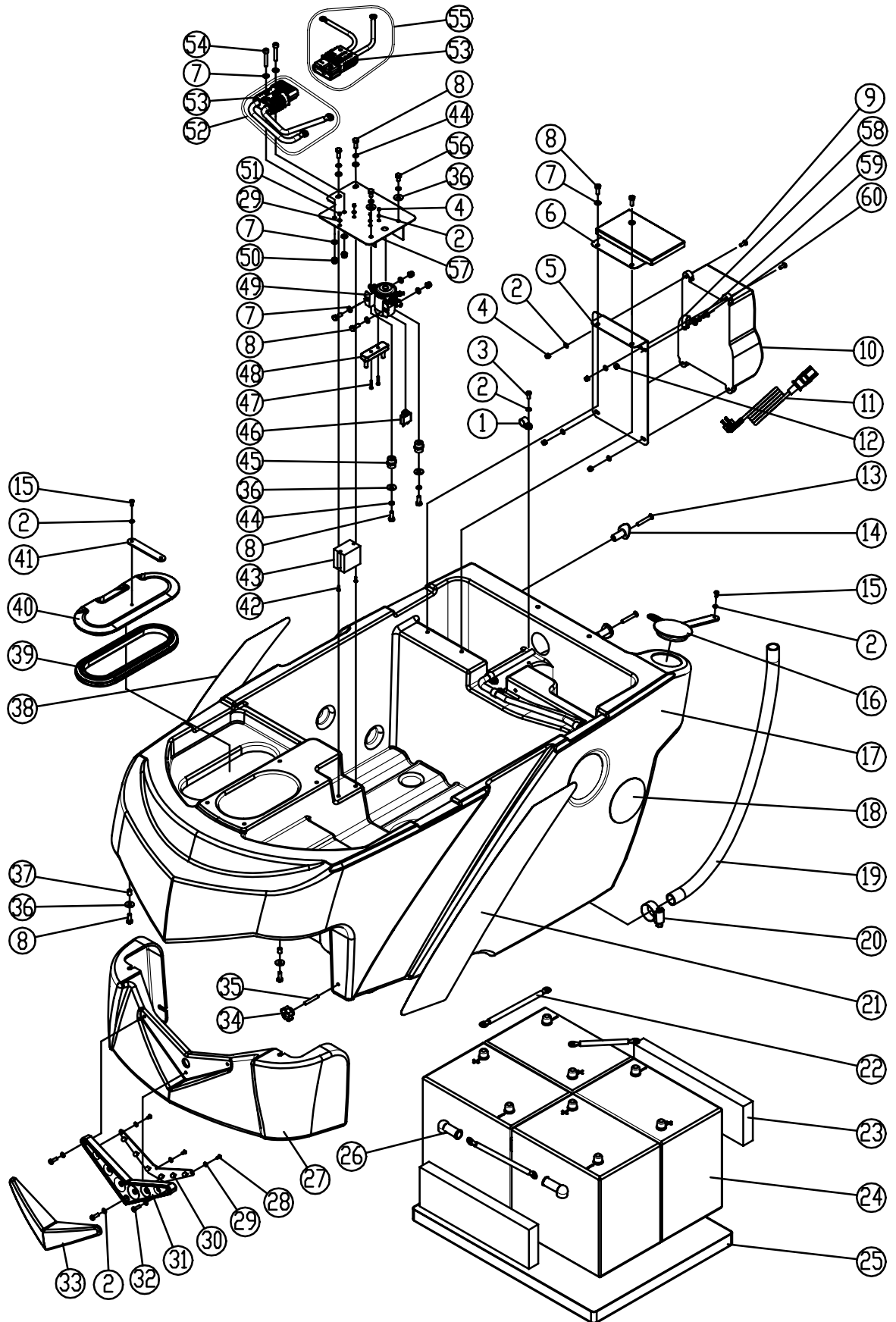

SOLUTION TANK GROUP

DIA NO.	PART NUMBER	DESCRIPTION	SERIAL NUMBER	NO REQ'D
1	6210131	NYLON, CLAMP		6
2	1421510	FLAT WASHER M5×10×1		20
3	1221512	SCREW M5×12		9
4	1123507	LOCK NUT M5		6
5	8210127	BRACKET, ON BOARD BATTERY CHARGER MNTG		1
	8210119	BRACKET, BATTERY CHARGER MNTG	60018100502~	1
6	8210117	CAP, CHARGER		1
7	1421612	FLAT WASHER M6×12×1.6		12
8	1021616	HEX BOLT M6 X 16		10
9	1221525	SCREW M5×25		4
10	8210106A	25A ON BOARD BATTERY CHARGER	i28BT : ~000342; i32BT : ~000235, 60007100239~60007100240	1
	8350425A	DELTA-Q BATTERY CHARGER, 24VDC 650W, OPTION	i28BT : 000342-000365, 60006100387-100493; i32BT : 000235-000238	1
	8350525	BATTERY CHARGER, 24VDC 650W	60018100496~	1
11	8112030	POWER CORD, FOR SPE BATTERY CHARGER(FOR 8210106A)	i28BT : ~000342; i32BT : ~000235, 60007100239~60007100240	1
	8350425A-C	POWER CORD, FOR DELTA-Q BATTERY CHARGER(FOR 8350425A),US PART-NUMBER	i28BT : 000342-000365, 60006100387-100493; i32BT : 000235-000238	1
	8312060US	POWER CORD, FOR BATTERY CHARGER(FOR 8350525)	60018100496~	1
12	1123406	LOCK NUT M4		1
13	1222641	SCREW M6 X 40		1
14	8210112	HOOK, CORD		2
15	1321213	SELF-TAPPING SCREW ST4.2X13		2
16	8210113	CAP, SOLUTION FILL		1
17	8210101	SOLUTION TANK		1
18	4010316	ICE LOGO		2
19	8210145	CLEAN TUBING		1
20	1962025	CLAMP 16-25MM		1
21	8210151	LABEL, LEFT SIDE		1
22	8210141	BATTERY CONNECT CABLE, BLACK		3
23	8113013	SPACER, BATTERY		2
24	8210105	BATTERY, 260AH @ 20Hr		4
25	8210107	BATTERY TRAY		1
26	8114751	JACKET, BATTERY TERMINAL, BLACK		8

PARTS LIST

SOLUTION TANK GROUP

DIA NO.	PART NUMBER	DESCRIPTION	SERIAL NUMBER	NO REQ'D
27	8210104	COVER, FRONT		1
28	1321110	SELF-TAPPING SCREW ST3.5 ×10		3
29	1421409	FLAT WASHER M4×9×0.8		5
30	8133610	LED LIGHT, KIT		1
31	8133601	LED LIGHT MNTG BASE		1
32	1221520	SCREW M5X20		3
33	8133602	LED LIGHT COVER		1
34	8210531	KNOB, M6		2
35	1535630	SET SCREW M6 ×30		2
36	1421618	PLAIN WASHER 6×18×1.6,SS		6
37	8113112	BUSHING		2
38	8210152	LABEL, RIGHT SIDE		1
39	8113030	SEAL		1
40	8113002	COVER		1
41	8113007	STRAP		1
42	1221412	SCREW M4×12		2
43	8210421	RELAY		1
44	1422616	LOCK WASHER, M6		6
45	8114705	STAND-OFF, M6, RED		2
46	8114703	CIRCUIT BREAKER, 35A		1
47	1222520	SCREW M5X20		2
48	8210422	60A FUSE ASSEMBLY		1
	8210423	FUSE, 60A		1
49	8124704	SOLENOID SWITCH		1
50	1123608	LOCK NUT M6		4
51	1123406	LOCK NUT M4		2
52	8210160	BATTERY CONNECT CABLE, ASSEMBLY		1
53	8210161	CONNECTOR, SB175-RED		2
54	1521635	SCREW, HEX SOCKET, M6 X 35		2
55	8210165	BATTERY CONNECT CABLE, ASSEMBLY		1
56	1021610	HEX BOLT M6 × 10		2
57	8210126	BRACKET, SOLENOID SWITCH		1
58	1885119	NYLON, CLAMP		1
59	1422411	SPRING WASHER		1
60	1221412	SCREW M4×20		1

Note:

No.5,10: Charger supplier replacement, the parts involved replacement.

No.12,58,59,60 : Structure optimization new parts.

CONTROL CONSOLE GROUP

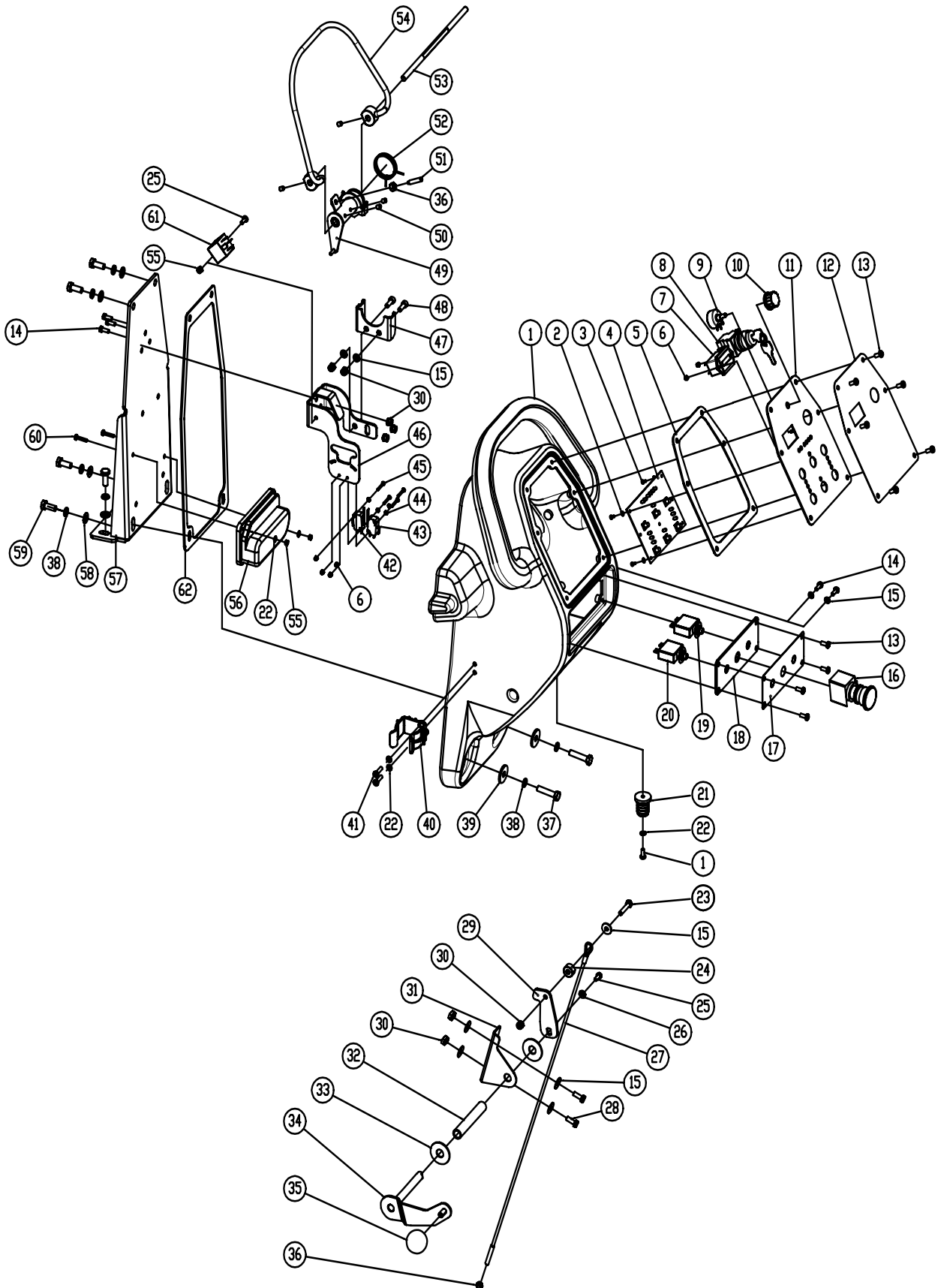

PARTS LIST

CONTROL CONSOLE GROUP

DIA NO.	PART NUMBER	DESCRIPTION	SERIAL NUMBER	NO REQ'D
1	8134001	CONTROL CONSOLE HOUSING		1
2	1421307	FLAT WASHER M3×7×0.5		5
3	1221306	SCREW M3×6		5
4	8210401	PCB ASSEMBLY		1
5	8134015	GASKET		1
6	1123305	LOCK NUT M3		6
7	8114710	TIMER		1
8	8114709	KEY SWITCH		1
	8114752	KEY		1
9	8124717A	POTENTIOMETER, KIT		1
10	8124718	KNOB, POTENTIOMETER		1
11	8210410	CONTROL PANEL		1
12	8210415	CONTROL PANEL DECAL, i28BT		1
	8210412	CONTROL PANEL DECAL, i32BT		1
13	1221512	SCREW M5×12		12
14	1021616	HEX BOLT M6 X 16		5
15	1421618	PLAIN WASHER 6×18×1.6,SS		9
16	8310707	EMERGENCY STOP BUTTON		1
17	8144029	DECAL, EMERGENCY STOP		1
18	8134008	PLATE, EMERGENCY STOP MNTG		1
19	8114703	CIRCUIT BREAKER, 35A		1
20	8310740	CIRCUIT BREAKER, 5A		1
21	8114005	CONNECTOR		1
22	1421510	FLAT WASHER M5×10×1.0		5
23	1021630	HEX HEAD BOLT M6×30,SS		1
24	8014101	LIFTING ROPE SPACER		1
25	1021512	HEX HEAD BOLT M5×12,SS		2
26	1421515	FLAT WASHER M5×15×1.0		1
27	8210413	CABLE, SQGE LIFT		1
28	1021620	HEX HEAD BOLT, M6 ×20		2
29	8014012	BAFFLE		1
30	1123608	LOCK NUT M6		8
31	8134501	BRACKET		1
32	8134508	SLEEVE		1
33	1421132	FLAT WASHER 12×32×1.5		2
34	8014010	SQUEEGEE LIFTING HANDLE		1

CONTROL CONSOLE GROUP

DIA NO.	PART NUMBER	DESCRIPTION	SERIAL NUMBER	NO REQ'D
35	8113104	BALL KNOB M8		1
36	1121605	HEX NUT M6		2
37	1021840	HEX BOLT M8×40		2
38	1422821	LOCK WASHER M8		8
39	1421828	FLAT WASHER M8×28×3		2
40	6210120	CLAMP, DRAIN HOSE		1
41	1221515	PH SCREW M5×15,SS		2
42	8124743	MICRO SWITCH		1
43	8114712	MICRO SWITCH		1
44	1434300	LOCK WASHER, TOOTH, M3		4
45	1021320	SCREW M3×20		4
46	8134022	BRACKET, SWITCH		1
47	8114402	BRACKET, SPRING		1
48	1521616	SCREW M6X16, HEX SCOKET		2
49	8114300	ACTUATOR		1
50	1534608	SET SCREW M6 ×8		4
51	1535630	SET SCREW M6 ×30		1
52	8114306	SPRING		1
53	8114101	SHAFT		1
54	8134300	LEVER, BAIL		1
55	1123507	LOCK NUT M5		3
56	8124501B	SPEED CONTROL BOARD		1
57	8134021	REAR PLATE, CONTROL CONSOLE		1
58	1421824	FLAT WASHER M8×24×2		6
59	1021820	HEX BOLT M8×20		6
60	1021535	SCREW, M5 × 35		2
61	8114707	RELAY, 40A		1
62	8134086	SEALING RING ON back OF CONTROL BOX	60018100496~	1

NOTES:

NO 40: Supplier change, code update.

NO 62: Design optimization of new parts.

FRAME & TRANSAXLE GROUP

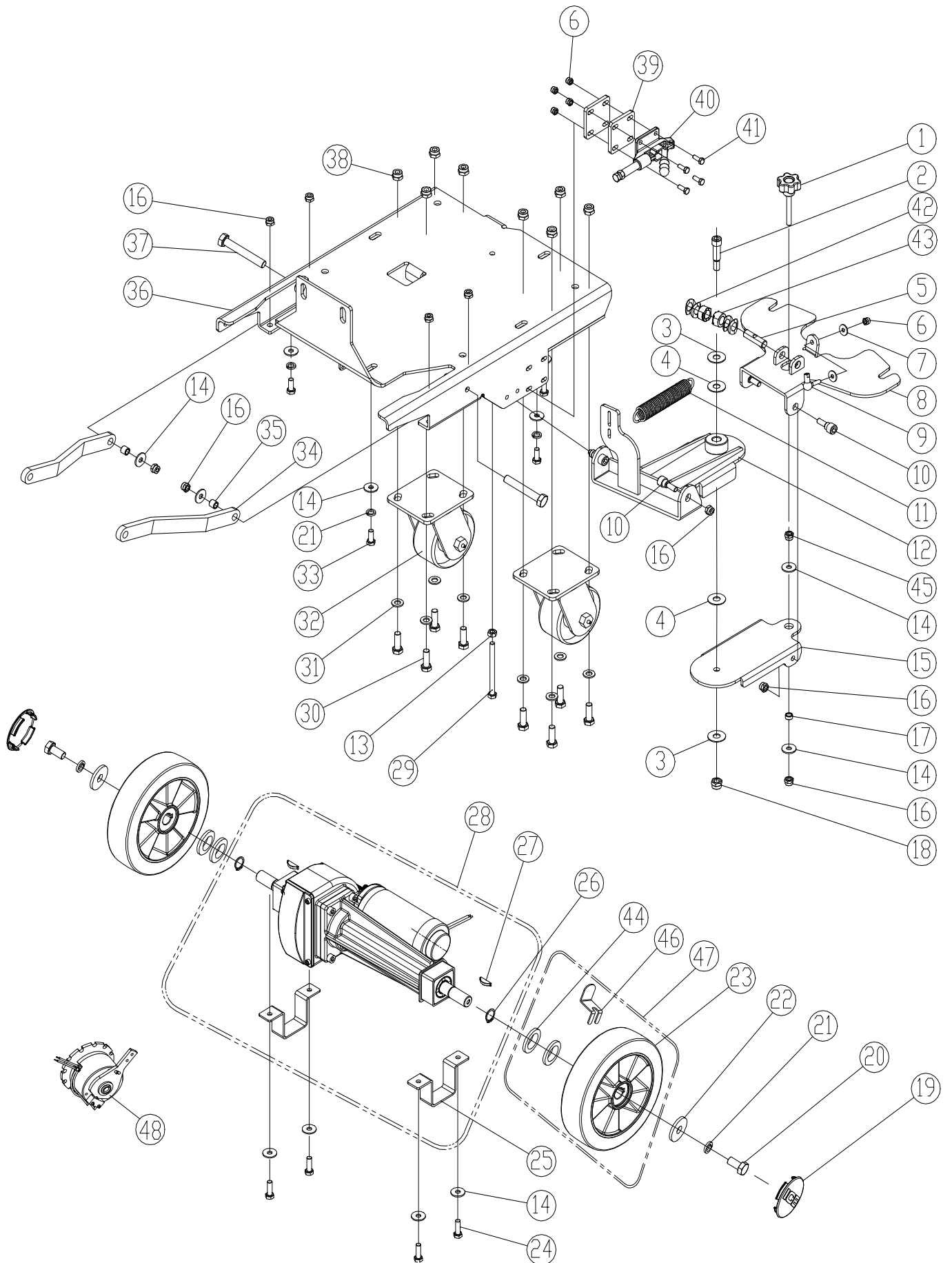

FRAME & TRANSAXLE GROUP

DIA NO.	PART NUMBER	DESCRIPTION	SERIAL NUMBER	NO REQ'D
1	8211507	KNOB M8 ×60		1
2	8211505	SHOULDER SCREW,M12		1
3	1421132	FLAT WASHER 12×32×1.5		2
4	8135001	PLASTIC THRUST WASHER M12× ϕ 30×1.5		2
5	8211506	SHAFT		1
6	1123608	LOCK NUT M6		7
7	1421618	FLAT WASHER M6×18×1.6		2
8	8211503	BRACKET, SQUEEGEE		1
9	8114511	BALL JOINT M6		1
10	8211504	SHOULDER SCREW,M8		4
11	8210508	SPIRNG		1
12	8211501	BRACKET, SQGE LIFT		1
13	1121807	NUT, M8		2
14	1421824	FLAT WASHER M8×24×2		12
15	8211502	BRACKET,SQGE SWING		1
16	1123810	LOCK NUT M8		11
17	8211508	BUSHING		1
18	1123115	LOCK NUT M12		1
19	8115203	COVER, WHEEL		2
20	1021816	HEX BOLT M8 × 16		2
21	1422821	LOCK WASHER M8		7
22	1421828	FLAT WASHER M8×28×2		2
23	8225203	FOAM FILLED WHEEL, 8INCH		2
24	1021825	HEX BOLT M8 × 25		4
25	8210123	BRACKET, TRANSAXLE MNTG		2
26	1436019	RETAINING RING 19		2
27	8125403	WOODRUFF KEY		2
28	8210120A	TRANSAXLE, 24VDC		1
29	1022800	HEX BOLT M8 X 100		1
30	1021030	HEX BOLT M10 X 30		8
31	1421020	FLAT WASHER 10×20×2.0		8
32	8210109	4" CASTER		2
33	1021820	HEX BOLT M8×20		5
34	8210115	ARM, SCRUB HEAD LIFTING		2
35	8210116	BUSHING		2
36	8210130	FRAME		1
37	1021855	HEX BOLT M8 × 55		2
38	1123012	LOCK NUT M10		8

PARTS LIST

FRAME & TRANSAXLE GROUP

DIA NO.	PART NUMBER	DESCRIPTION	SERIAL NUMBER	NO REQ'D
39	8210138	SPACER (OPTION)		2
40	8210137	TOGGLE CLAMP, BRAKE (OPTION)		1
41	1021630	HEX BOLT M6 X 30		4
42	1435013	GASKET	60018100496~	4
43	8118085	SHAFT SLEEVE	60018100496~	2
44	8116001	GASKET	60018100496~	4
45	1123809	METAL LOCK NUTS		1
46	8225205	BRACKET		1
47	8225210	FOAM FILLED WHEEL, 8INCH, KIT		1
48	8210122	BRAKE ASSEMBLY(FOR TRANSAXLE 8210120A)		1

Note:

No.42~44:Structure optimization new parts.

No.45:The changes are consistent with the real objects.

SCRUB HEAD GROUP

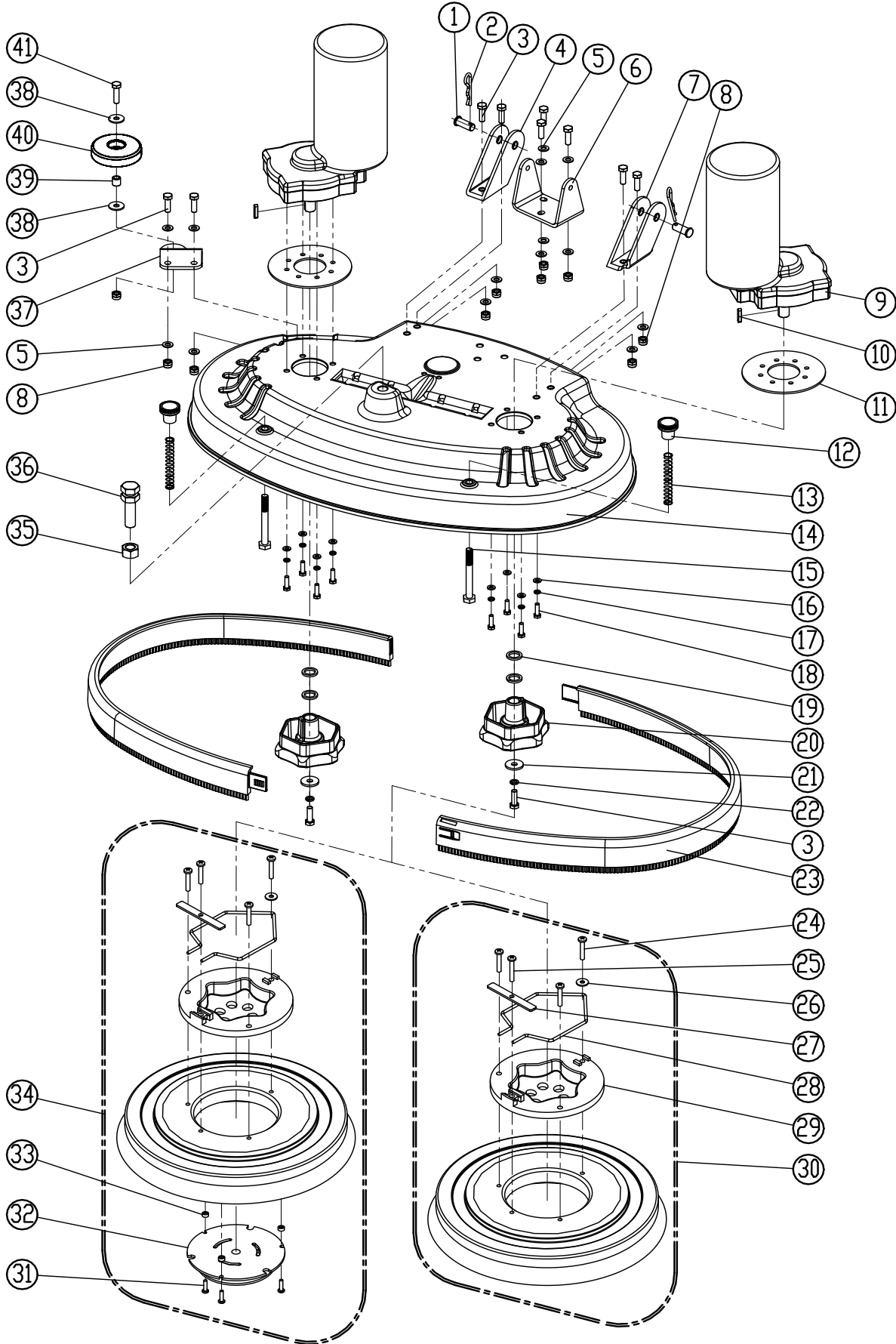

PARTS LIST

SCRUB HEAD GROUP

DIA NO.	PART NUMBER	DESCRIPTION	SERIAL NUMBER	NO REQ'D
1	8210807	PIN	60061000102~60006100478 60020000111~60020100240	2
	8210812	PIN	60018100479~	
2	8210309	PIN, COTTER		2
3	1021825	HEX BOLT M8 × 25		11
4	8210830	BRACKET, SCRUB HEAD LIFT, RIGHT	60061000102~60006100478 60020000111~60020100240	1
	8210831	BRACKET, SCRUB HEAD LIFT, RIGHT	60018100479~	1
5	1421816	FLAT WASHER M8×16×1.6		14
6	8210806	BRACKET, ACTUATOR MNTG		1
7	8210820	BRACKET, SCRUB HEAD LIFT, LEFT	60061000102~60006100478 60020000111~60020100240	1
	8210832	BRACKET, SCRUB HEAD LIFT, LEFT	60018100479~	1
8	1123810	LOCK NUT M8		10
9	8210899	BRUSH MOTOR, 24VDC, 550W, KIT		2
	8210850	CARBON BRUSH		2
10	1655025	KEY, 5X5X25		2
11	8210803	SPACER, RUBBER		2
12	8210808	KNOB, M10		2
13	8210809	SPRING		2
14	8220801	HOUSING, SCRUB HEAD, i28BT		1
	8210801	HOUSING, SCRUB HEAD, i32BT		1
15	1022090	HEX BOLT M10 × 90		2
16	1421612	FLAT WASHER M6×12×1.6		8
17	1422616	LOCK WASHER, M6		8
18	1021620	HEX BOLT M6 × 20		8
19	8210804	SPACER		4
20	8210805	HUB, BRUSH DRIVE		2
21	1421828	FLAT WASHER M8×28×3.0		2
22	1422821	LOCK WASHER M8		2
23	8220810	BUMPER, SCRUB HEAD, i28BT		2
	8218050	BUMPER, SCRUB HEAD, i32BT		2
24	1221635	SCREW, M6 × 35		12
25	1221640	SCREW, M6 × 40		4
26	1421618	FLAT WASHER M6×18×1.6		4
27	8210861	RETAINER BAR		4
28	8210862	SPRING, G-400S		4
29	9000004	CLUTCH, G-400S		4

SCRUB HEAD GROUP

DIA NO.	PART NUMBER	DESCRIPTION	SERIAL NUMBER	NO REQ'D
30	9050014	BRUSH ASSEMBLY, 14 INCH, i28BT, OPTION		2
	9050014P	SOFT WHITE BRUSH ASSEMBLY, 14 INCH, i28BT, OPTION		2
	9050016	BRUSH ASSEMBLY, 16 INCH, i32BT, OPTION		2
	9050016P	SOFT WHITE BRUSH ASSEMBLY, 16 INCH, i32BT, OPTION		2
31	1321325	SELF-TAPPING SCREW, ST5 X 25		6
32	9000003	CENTER LOCK, #3		2
33	8116040	SPACER, 6.5×14.5×7.0		6
34	9040014	PAD DRIVER, 14INCH, i28BT		2
	9040016	PAD DRIVER, 14INCH, i32BT		2
35	1111215	HEX NUT, M16		1
36	8210811	AJUSTMENT STUD, M16		1
37	8210810	BRACKET, ROLLER MNTG		1
38	1421824	FLAT WASHER M8×24×2		2
39	8115404	SLEEVE, P/M		1
40	8116009	PROTECTIVE WHEEL		1
41	1021830	HEX BOLT M8 × 30		1

Note:

No.4、7:Structure optimization new parts.

SCRUB HEAD LIFT GROUP

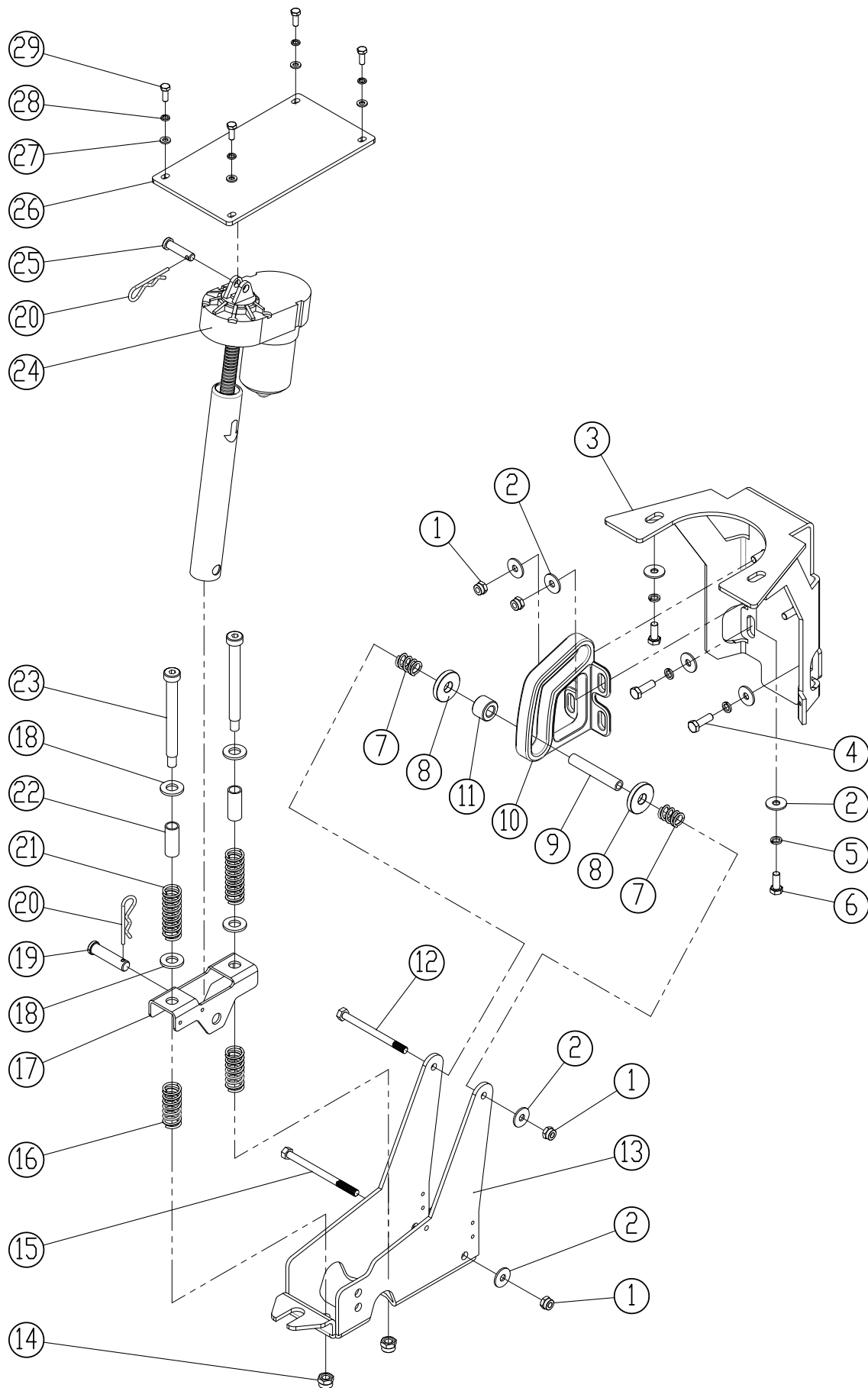

SCRUB HEAD LIFT GROUP

DIA NO.	PART NUMBER	DESCRIPTION	SERIAL NUMBER	NO REQ'D
1	1123810	LOCK NUT M8		6
2	1421824	FLAT WASHER M8×24×2		10
3	8210306	BRACKET, GUIDE MNTG		1
4	1021825	HEX BOLT M8×25		2
5	1422821	LOCK WASHER M8		4
6	1021820	HEX BOLT M8×20		2
7	8210311	SPRING		2
8	8210312	WASHER, PM		2
9	8210314	SHAFT		1
10	8210310	GUIDE, ROLLER		1
11	8210313	ROLLER		1
12	1022800	HEX BOLT M8 X 100		1
13	8210316	BRACKET, SCRUB LIFT		1
14	1123008	LOCK NUT 3/8		2
15	1022811	HEX BOLT M8 X 110		1
16	8210319	SPRING		2
17	8210317	BRACKET, SPRING		1
18	1421132	FLAT WASHER 12×32×1.5		4
19	8210322	PIN		1
20	8210309	PIN, COTTER		2
21	8210318	SPRING		2
22	8210320	SLEEVE		2
23	8210321	BOLT, SHOULDER, 3/8		2
24	8210302	ACTUATOR, 24VDC		1
25	8210301	PIN		1
26	8210303	BRACKET, ACTUATOR MNTG		1
27	1421612	FLAT WASHER M6×12×1.6		4
28	1422616	LOCK WASHER M6		4
29	1021616	HEX BOLT M6 X 16		4

46.5 INCH SQUEEGEE GROUP, i32BT (STANDARD)

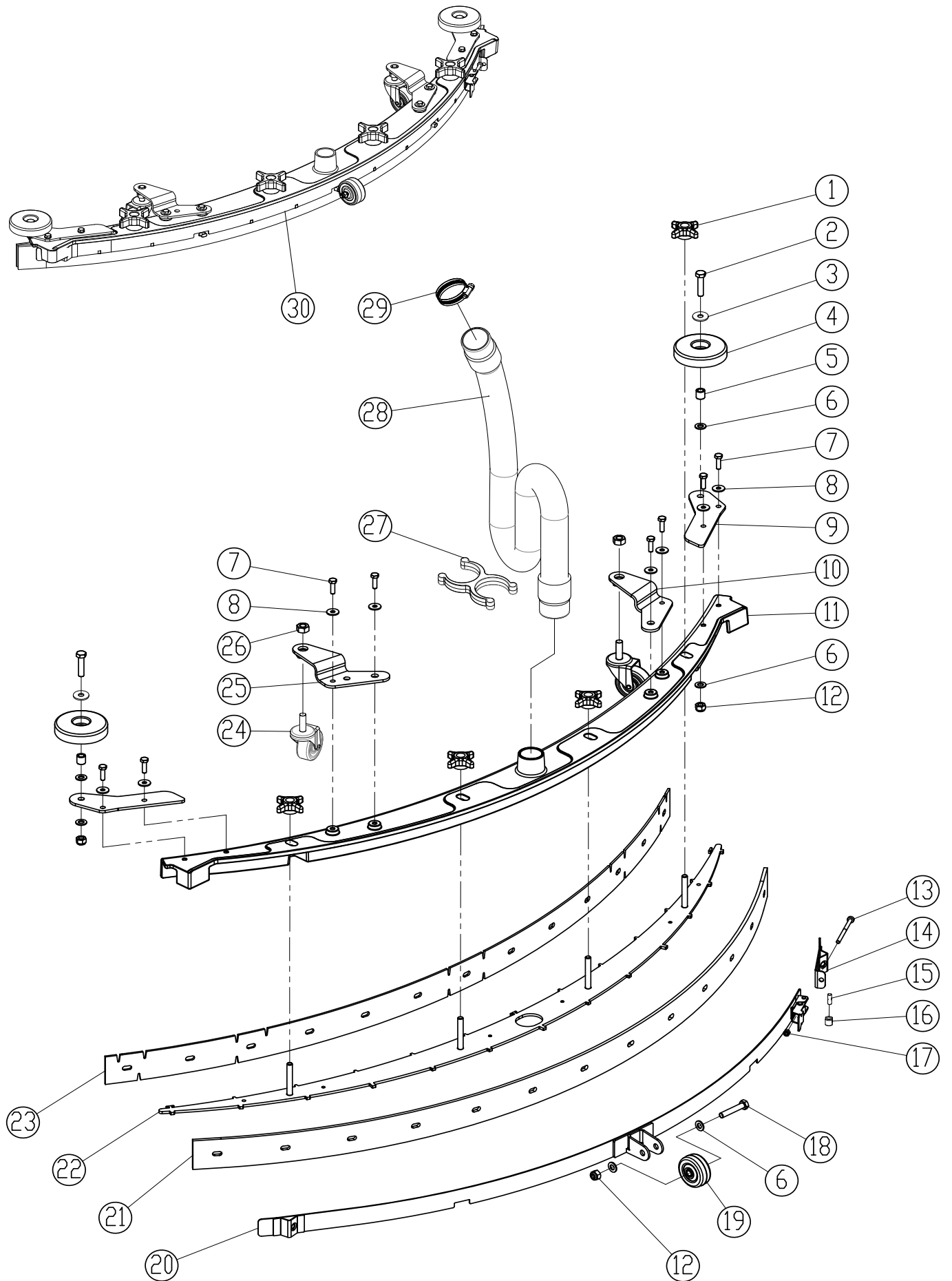

46.5 INCH SQUEEGEE GROUP, i32BT (STANDARD)

DIA NO.	PART NUMBER	DESCRIPTION	SERIAL NUMBER	NO REQ'D
1	8210518	STAR KNOB M8		4
2	1021835	HEX BOLT M8×35		2
3	1421824	FLAT WASHER M8×24×2.0		2
4	8116009	PROTECTIVE WHEEL		2
5	8115404	BEARING, JOURNAL		2
6	1421816	FLAT WASHER M8×16×1.6		6
7	1021616	HEX BOLT M6×16		8
8	1421618	FLAT WASHER M6×18×1.6		8
9	8210515	BRACKET, ROLLER MNTG		2
10	8118300	LEFT BRACKET		1
11	8230501	SQUEEGEE HOUSING		1
12	1123810	LOCK NUT M8		2
13	1221575	SCREW M5×75		1
14	8210525	SHORT CLAMP ASSEMBLY		1
15	8118624	SHAFT		1
16	8118623	SPACER		1
17	1123507	LOCK NUT M5		1
18	1022845	HEX BOLT M8×45		1
19	8210527	WHEEL, 2 INCH		1
20	8210520	CLAMP ASSEMBLY, SQUEEGEE		1
21	8230504	SQUEEGEE BLADE, REAR, LINATEX		1
	8230534	SQUEEGEE BLADE, REAR, PU (OPTION)		1
22	8230502	RETAINER,SQUEEGEE		1
23	8230503	SQUEEGEE BLADE, FRONT, LINATEX		1
	8230513	SQUEEGEE BLADE, FRONT, PU (OPTION)		1
24	8118400	CASTER, 2 INCH		2
25	8118200	RIGHT BRACKET		1
26	1121008	HEX NUT M10		2
27	8118109	HOLDER VACUUM HOSE		1
28	8118006	VACUUM HOSE		1
	8118018	VACUUM HOSE		1
29	1962050	CLAMP		1
30	8230500	SQUEEGEE ASSEMBLY FOR i32BT, 46.5 INCH, STANDARD		1

Note:No28: supplier replacement code replacement, suitable for old models;

44.5 INCH SQUEEGEE GROUP, i32BT(OPTION)

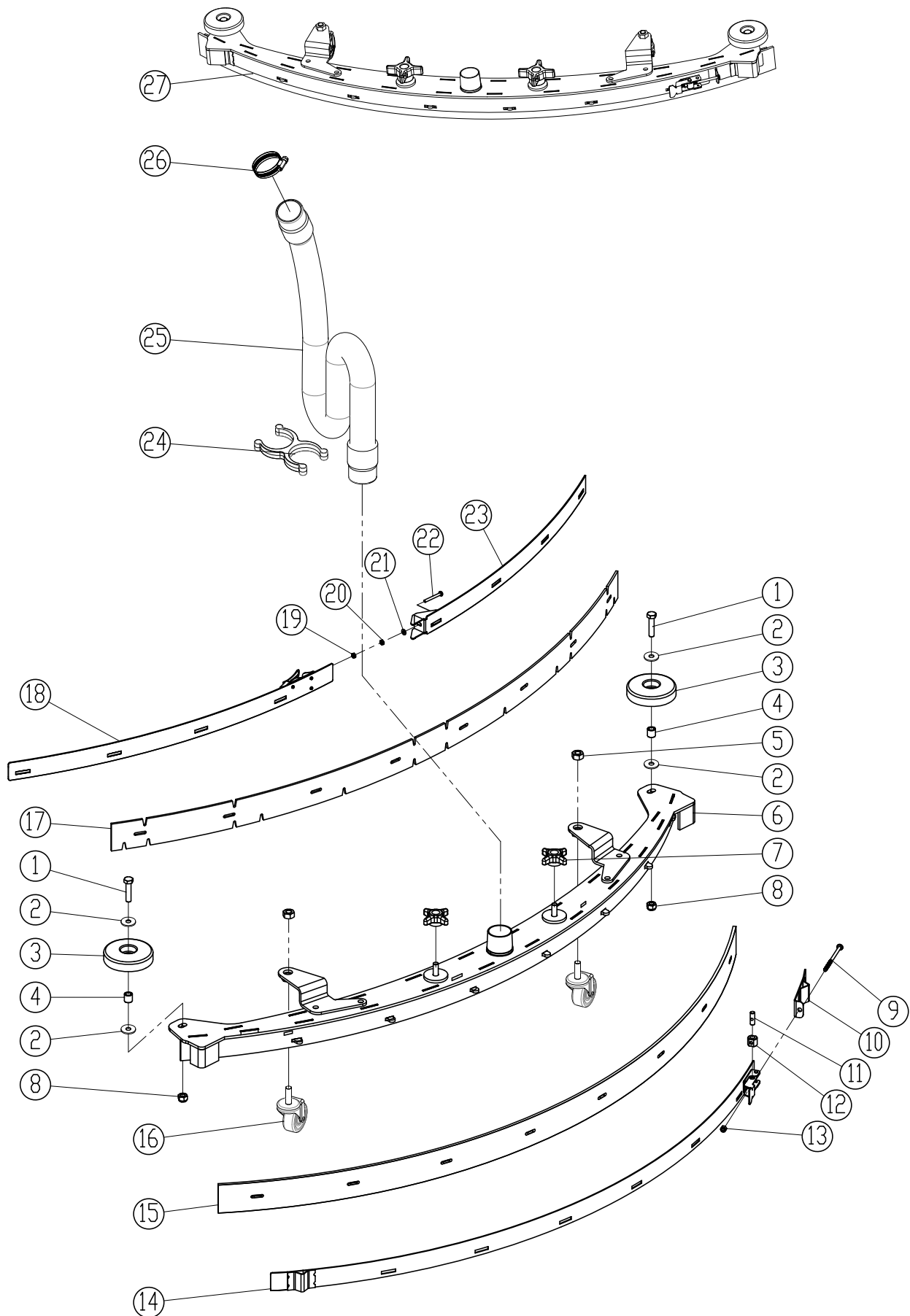

44.5 INCH SQUEEGEE GROUP, i32BT(OPTION)

DIA NO.	PART NUMBER	DESCRIPTION	SERIAL NUMBER	NO REQ'D
1	1021835	HEX BOLT M8×35		2
2	1421824	FLAT WASHER M8×24×2.0		2
3	8116009	PROTECTIVE WHEEL		2
4	8115404	BEARING, JOURNAL		2
5	1121008	HEX NUT M10		2
6	8220501	SQUEEGEE HOUSING		1
7	8210518	STAR KNOB M8		2
8	1123810	LOCK NUT M8		2
9	1221575	SCREW M5×75		1
10	8210525	SHORT CLAMP ASSEMBLY		1
11	8118624	SHAFT		1
12	8118623	SPACER		1
13	1123507	LOCK NUT M5		1
14	8220521	CLAMP ASSEMBLY, SQUEEGEE		1
15	8220513	SQUEEGEE BLADE, REAR, LINATEX		1
	8220523	SQUEEGEE BLADE, REAR, PU (OPTION)		1
16	8118400	CASTER, 2 INCH		2
17	8220514	SQUEEGEE BLADE, FRONT, LINATEX		1
	8220524	SQUEEGEE BLADE, FRONT, PU (OPTION)		1
18	8220518	FRONT CLAMP, LEFT		1
19	1121403	HEX NUT M4		1
20	1123406	LOCK NUT M4		1
21	1421409	FLAT WASHER M4×9×0.5		1
22	1211435	SCREW M4×35		1
23	8220515	FRONT CLAMP, LEFT		1
24	8118109	HOLDER VACUUM HOSE		1
25	8118006	VACUUM HOSE		1
	8118018	VACUUM HOSE		1
26	1962050	CLAMP		1
27	8220500	SQUEEGEE ASSEMBLY, 44.5 INCH		1

Note:No25: supplier replacement code replacement, suitable for old models;

40.5 INCH SQUEEGEE GROUP,i28BT(STANDARD)

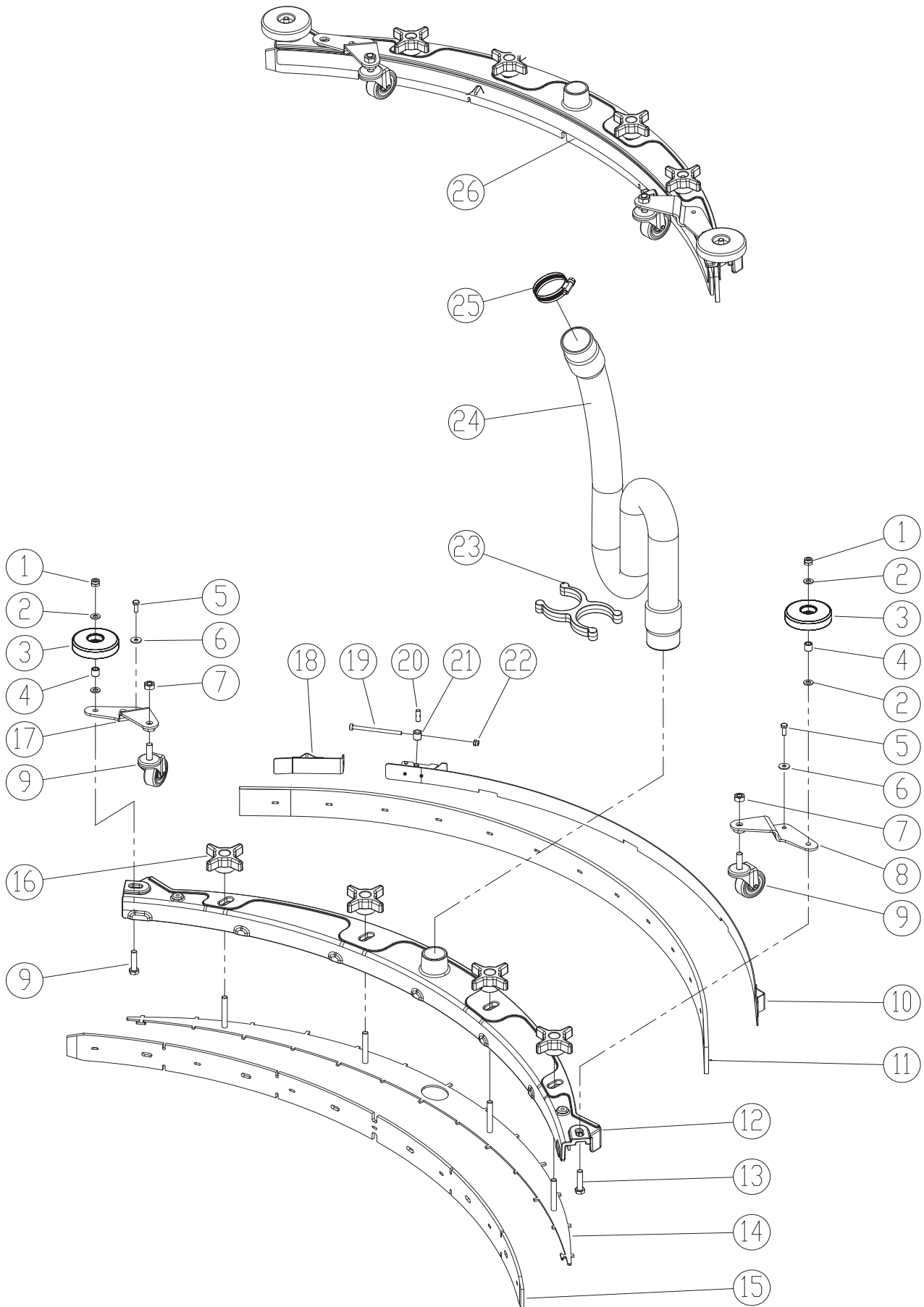

40.5 INCH SQUEEGEE GROUP,i28BT(STANDARD)

DIA NO.	PART NUMBER	DESCRIPTION	SERIAL NUMBER	NO REQ'D
1	1123810	LOCK NUT M8		2
2	1421824	FLAT WASHER M8× ϕ 24×2.0		4
3	8116009	PROTECTIVE WHEEL		2
4	8115404	BEARING, JOURNAL		2
5	1021616	HEX BOLT M6×16		2
6	1421612	FLAT WASHER M6× ϕ 12×1.6		2
7	1121008	HEX NUT M10		2
8	8118300	LEFT BRACKET		1
9	8310550	CASTER, 2 INCH		2
10	8310514	CLAMP ASSEMBLY		1
11	8310535	SQUEEGEE BLADE, REAR, LINATEX		1
	8310545	SQUEEGEE BLADE, REAR, PU (OPTION)		1
12	8310561	SQUEEGEE HOUSING		1
13	1021835	BOLT, HEX HEAD, M8×35		2
14	8310512	RETAINER, SQUEEGEE		1
15	8310536	SQUEEGEE BLADE, FRONT, LINATEX		1
	8310546	SQUEEGEE BLADE, FRONT, PU (OPTION)		1
16	8210518	STAR KNOB M8		2
17	8118200	RIGHT BRACKET		1
18	8210525	SHORT CLAMP ASSEMBLY		1
19	1221575	SCREW M5×75		1
20	8118624	SHAFT		1
21	8118623	SPACER		1
22	1123507	LOCK NUT M5		1
23	8118109	HOLDER VACUUM HOSE		1
24	8118006	VAGUUM HOSE		1
	8118018	VACUUM HOSE		1
25	1962050	CLAMP		1
26	8310570	SQUEEGEE ASSEMBLY, 40.5 INCH		1

Note:No24: supplier replacement code replacement, suitable for old models;

SOLUTION GROUP

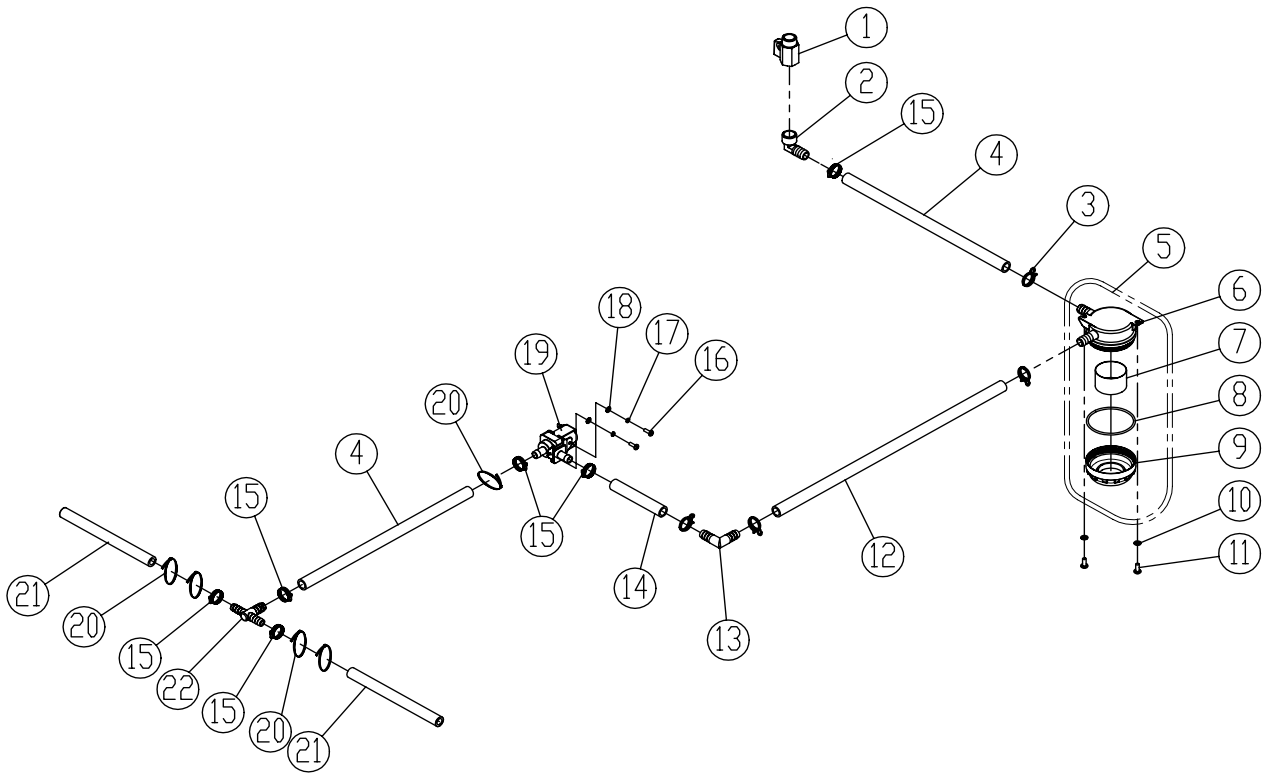

SOLUTION GROUP

DIA NO.	PART NUMBER	DESCRIPTION	SERIAL NUMBER	NO REQ'D
1	8119005	BALL VALVE, G1/2		1
2	8119007	ELBOW G1/2		1
3	8119006	CLAMP		4
4	8210901	TUBING ID=12MM L=330MM		2
5	8119200	FILTER ASSEMBLY, 40 MESH		1
6	8119101	BASE, FILTER ASSEMBLY		1
7	8119105	SCREEN, FILTER, 40 MESH		1
8	1622760	O RING		1
9	8119102	CAP, FILTER ASSEMBLY		1
10	1421510	FLAT WASHER M5×10×1		2
11	1221512	SCREW M5×12		2
12	8210902	TUBING ID=12MM L=480MM		1
13	8119002	ELBOW, TUBING BARB		1
14	8210903	TUBING ID=12MM L=120MM		1
15	1962016	CLAMP, 10-16mm		6
16	1221412	SCREW M4×12		2
17	1422411	LOCK WASHER M4		2
18	1421409	FLAT WASHER M4×9×0.8		2
19	8119003	SOLENOID VALVE,24VDC		1
20	1914300	TIE, NYLON, 5X300		5
21	8210904	TUBING ID=10MM L=180MM		2
22	8119008	FITTING, PLASTIC, TEE		1

CYLINDRICAL SCRUB HEAD GROUP

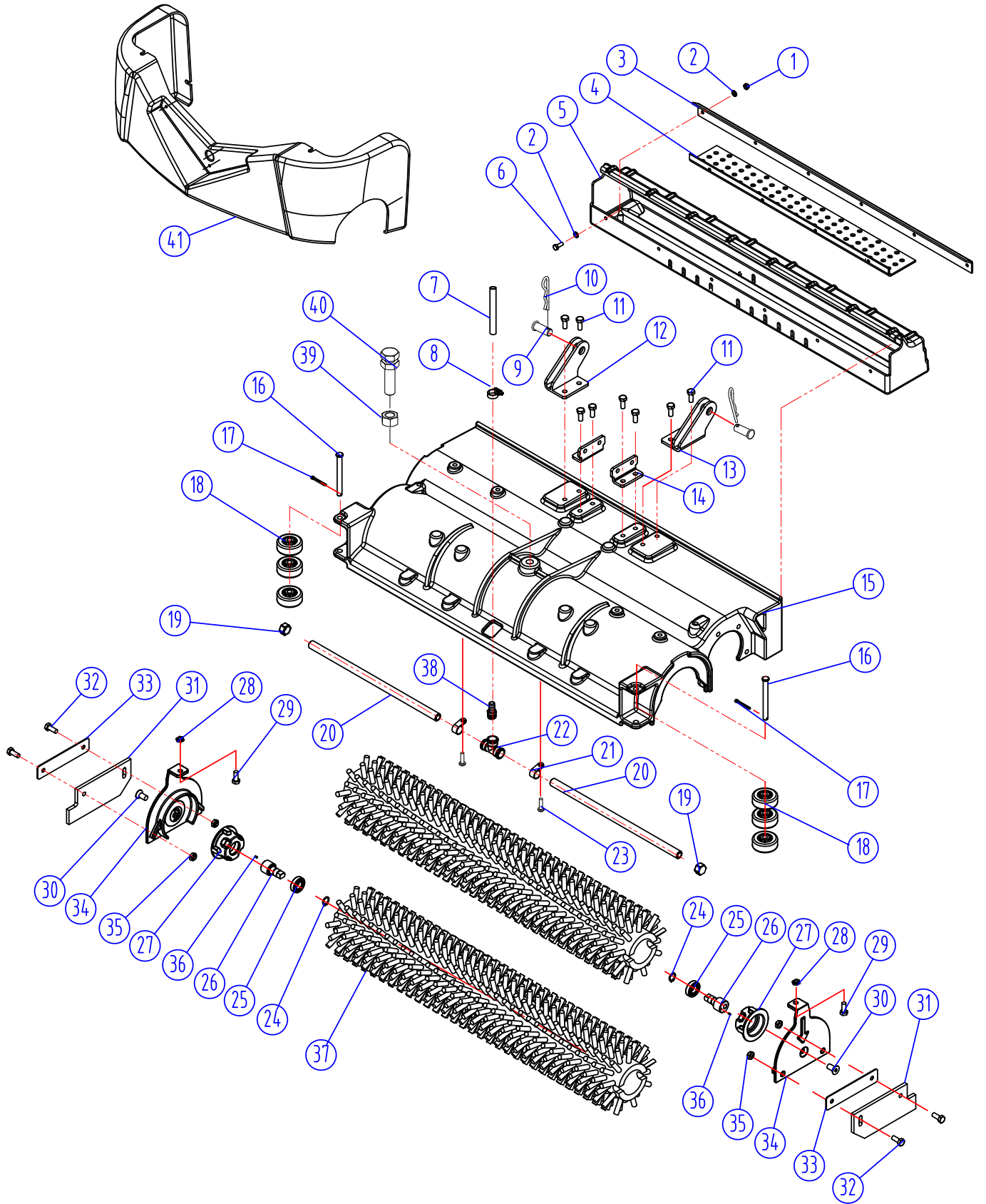

CYLINDRICAL SCRUB HEAD GROUP

DIA NO.	PART NUMBER	DESCRIPTION	SERIAL NUMBER	NO REQ'D
1	1123608	LOCK NUT, M6		6
2	1421612	FLAT WASHER, M6 X 12 X 1.6		12
3	8216107	LIP, HOPPER		1
4	8236020	STRIP, HOPPER		1
5	8216104	HOPPER, 28"		1
6	1021616	HEX BOLT, M6 X 16		6
7	8216113	TUBING, ID=12 X 550MM		1
8	1962016	CLAMP, 16MM		1
9	8210807	PIN		2
10	8210309	PIN, COTTER		2
11	1021820	SCREW, M8 X 20		8
12	8216110	BRACKET, SCRUB HEAD LIFT, LEFT	~60019000329	1
	8216116	BRACKET, SCRUB HEAD LIFT, LEFT		1
13	8216109	BRACKET, SCRUB HEAD LIFT, RIGHT	~60019000329	1
	8216115	BRACKET, SCRUB HEAD LIFT, RIGHT		1
14	8216111	BRACKET, ACTUATOR MOUNTING		2
15	8216101	HOUSING CYLINDRICAL, 28"		1
16	8236011	PIN, M9.5X96		2
17	1645324	PIN, COTTER, M3.2 X 24		2
18	8236026	WHEEL, 2"		6
19	8146303	END CAP, 3/8"		2
20	8216108	PVC TUBING		2
21	8146305	PLASTIC CLAMP		4
22	8146301	TEE FITTING, 3/8"		1
23	1221512	SCREW, M5 X 12		4
24	1436015	RING RETAINING, M15		2
25	1612602	BEARING, 6002LLU		2
26	8236009	SHAFT, IDLER		2
27	8236008	PLUG, IDLER,BRUSH		2
28	1121804	NUT, M8		2
29	1021840	SCREW, M8 X 40		2
30	1513020	COUNTERSUNK HEX SCREW, M10X20		2
31	8236013	SKIRT, CYLINDRICAL		2
32	1021816	SCREW, M8 X 16		4
33	8236014	CLAMP, SKIRT		2
34	8236002	DOOR, BRUSH		2
35	1123810	LOCK NUT, M8		4
36	1644206	PIN, M2.5X6		2
37	8216105	BRUSH, CYLINDRICAL, 28"		2
38	8013007	TUBING FITTING		1
39	1111215	HEX NUT, M16		1
40	8210811	ADJUSTMENT STUD, M16		1
41	8216103	FRONT COVER		1

Note:No.12、13:Structure optimization new parts.

CYLINDRICAL SCRUB DRIVE GROUP

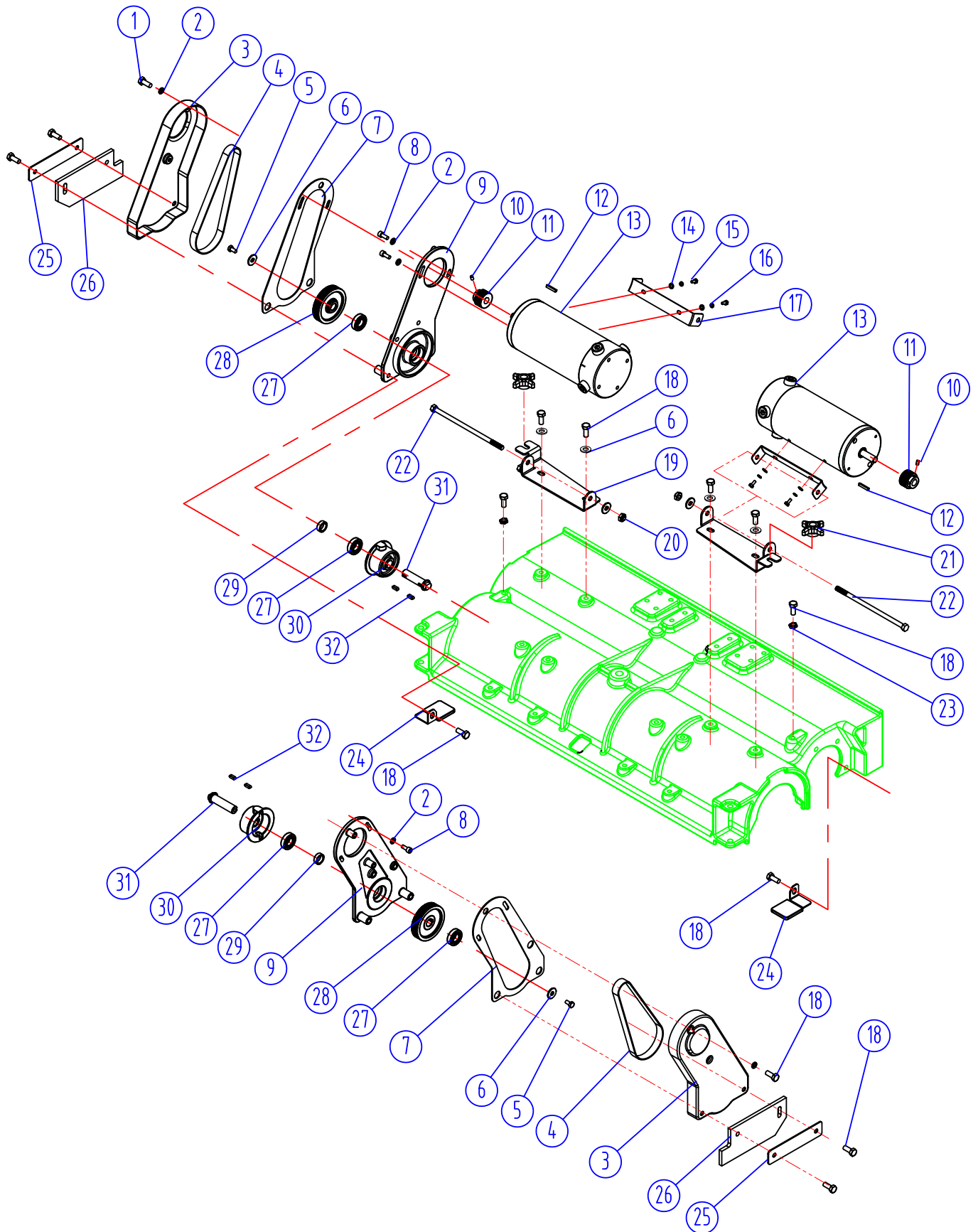

CYLINDRICAL SCRUB DRIVE GROUP

DIA NO.	PART NUMBER	DESCRIPTION	SERIAL NUMBER	NO REQ'D
1	1521612	HEX SOCKET SCREW, M6 X 12		4
2	1421612	FLAT WASHER, M6 X 12 X 1.6		8
3	8236018	COVER, BELT		2
4	8236027	BELT, DRIVE,6PJ 508MM		2
5	1021816	HEX BOLT, M8 X 16		2
6	1421824	FLAT WASHER, M8 X 24 X 2		8
7	8236029	GASKET, BELT		2
8	1521616	HEX SOCKET SCREW, M6 X 16		4
9	8236017	BRACKET, MOTOR MOUNTING		2
10	1534508	SCREW, M5 X 8		4
11	8236012	DRIVING PULLEY, 6PJ		2
12	8236023	KEY, 4 X 4 X 25		2
13	8216102	MOTOR, 24VDC,0.75HP		2
14	1421511	FLAT WASHER, M5 X 12 X 1		4
15	1021512	HEX BOLT, M5 X 12		4
16	1422513	WASHER, LOCK, M5 X 12 X 1		4
17	8236015	ANGLE BRACKET, MOTOR		2
18	1021820	HEX BOLT, M8 X 20		18
19	8236016	BRACKET, MOTOR		2
20	1123810	LOCK NUT, M8		2
21	8118003	STAR KNOB, M8		2
22	8236034	HEX BOLT, M8 X 185		2
23	1121804	NUT, M8		2
24	8236021	DEFLECTOR, WATER		2
25	8236014	CLAMP, SKIRT		4
26	8236013	SKIRT, CYLINDRICAL		4
27	1612602	BEARING, 6002LLU		4
28	8236007	DRIVEN PULLEY, 6PJ		2
29	8236024	BUSHING		2
30	8236025	PLUG, DRIVE, BRUSH		2
31	8236010	SHAFT		2
32	1655015	KEY,5 X 5 X 15		4

PARTS LIST

WEAR AND TEAR PARTS

DIA NO.	PART NUMBER	DESCRIPTION	SERIAL NUMBER	NO REQ'D
1	8225210	FOAM FILLED WHEEL, 8INCH, KIT (OPTION)		2
2	8116009	PROTECTIVE WHEEL		3
3	8210513	SQUEEGEE BLADE, FRONT, LINATEX		1
	8210516	SQUEEGEE BLADE, FRONT, PU (OPTION)		1
	8220514	SQUEEGEE BLADE, FRONT, LINATEX (OPTION)		1
	8220524	SQUEEGEE BLADE, FRONT, PU (OPTION)		1
	8310536	SQUEEGEE BLADE, FRONT, LINATEX (OPTION)		1
	8310546	SQUEEGEE BLADE, FRONT, PU (OPTION)		1
4	8210514	SQUEEGEE BLADE, REAR, LINATEX		1
	8210517	SQUEEGEE BLADE, REAR, PU (OPTION)		1
	8220513	SQUEEGEE BLADE, REAR, LINATEX (OPTION)		1
	8220523	SQUEEGEE BLADE, REAR, PU (OPTION)		1
	8310535	SQUEEGEE BLADE, REAR, LINATEX (OPTION)		1
	8310545	SQUEEGEE BLADE, REAR, PU (OPTION)		1
5	9050014	14" BRUSH , i28BT		2
	9050014P	14" SOFT WHITE BRUSH , i28BT		2
	9050016	16" BRUSH , i32BT		2
	9050016P	16" SOFT WHITE BRUSH , i32BT		2
6	9040014	14" PAD HOLDER, i28BT		2
	9040016	16" PAD HOLDER, i32BT		2
7	8216105	BRUSH, CYLINDRICAL, 28"		2
8	8144778	WIRING HARNESS KIT FOR i28BT/i32BT		1

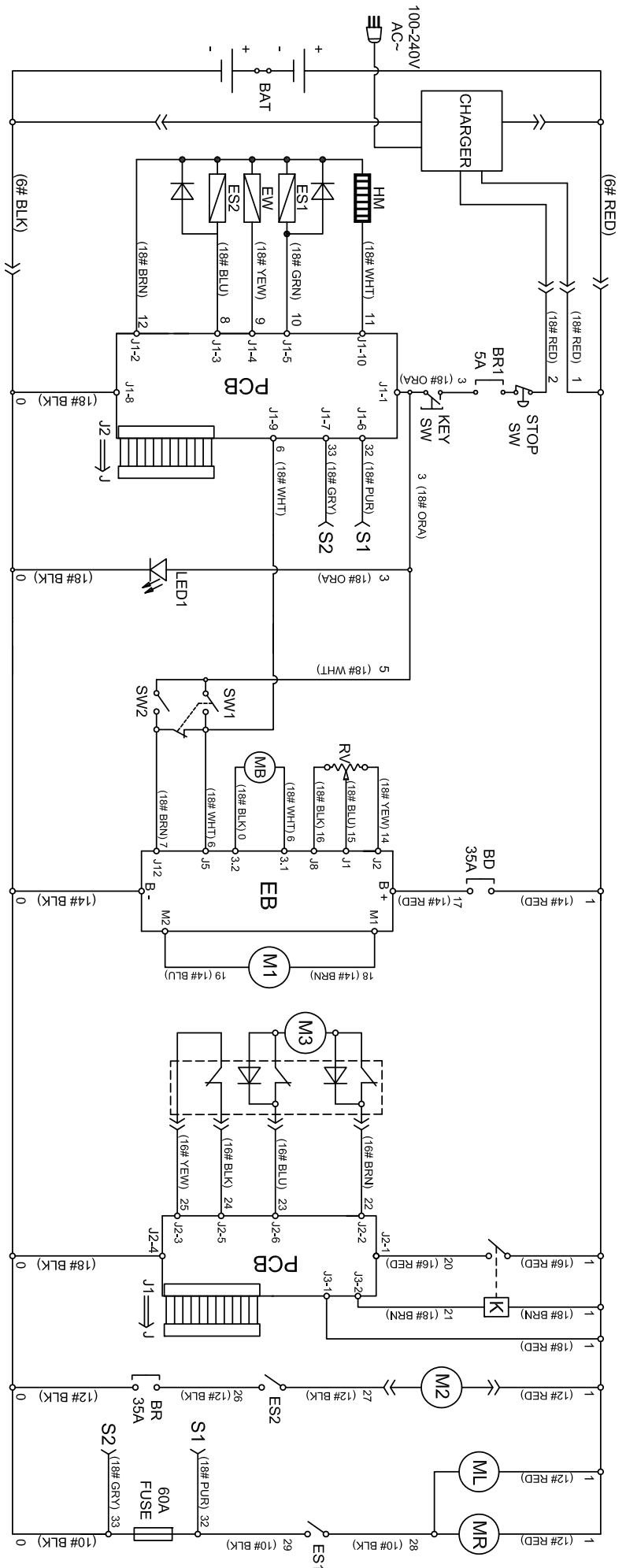

- BAT: 4-6V Batteries
- CHARGER: On board battery charger
- STOP SW: Emergency Stop switch
- BR1: Brake circuit breaker
- KEY SW: Main power Key switch
- HM: Hour meter
- ES1: Brush motor solenoid switch
- EW: Solution solenoid valve switch
- ES2: Vacuum motor relay
- PCB: Function electronic board
- LED1: Running lights
- BD: Driver motor circuit breaker

- RV: Speed potentiometer
- MB: Electromagnetic brake
- SW1: Control switch, forward
- SW2: Control switch, backward
- EB: Speed control board
- M1: Traction motor
- K: Relay
- M3: Scrub head lifting motor
- M2: Vacuum motor
- BR: Vacuum motor circuit breaker
- ML: Brush motor, left
- MR: Brush motor, right

CERTIFICATE OF QUALIFIED

MODEL: _____ SERIAL NO.: _____

INSPECTOR: _____ DATE: _____

ICE Cobotics (GuangDong) Company Limited

TEL:(+86) 769 8186 9000 FAX:(+86) 769 8186 3000