

ICE ROBOTICS

www.icecobotics.com



Operator & Parts Manual

175 RPM Floor Machine



**iP17
iP20**

4310403
REV.02(03-2024)



READ OPERATOR MANUAL CAREFULLY!

IMPORTANT: To ensure full warranty protection, please fill out & return your warranty card.

Please fill out at time of installation for future reference.

Model No. _____

Serial No. _____

Machine Options _____

Sales Rep. _____

Sales Rep. Phone No. _____

Customer ID Number _____

Installation Date _____

HOW TO ORDER PARTS

Only use ICE Cobotics Company supplied or equivalent parts. Parts and supplies may be ordered from authorized distributor.

1. Identify the machine model.
2. Identify the machine serial number from the data label.
3. Ensure the proper serial number is used from the parts list.
4. Identify the part number and quantity.
Do not order by page or reference numbers.
5. Provide your name, company name, customer ID number, billing and shipping address, phone number and purchase order number.

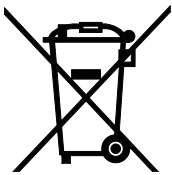

PROTECT THE ENVIRONMENT

Please dispose of packaging materials, old machine components such as batteries, hazardous fluids, including antifreeze and oil, in an environmentally safe way according to local waste disposal regulations.

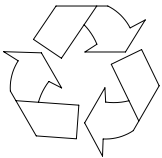

Always remember to recycle.

ICE Cobotics (GuangDong) Company Limited

XiangShi Road LiaoBu DongGuan GuangDong China

Tel: 0769 - 81869000

Fax: 0769 - 81863000

Specifications and parts are subject to change without notice.

TABLE OF CONTENTS

SAFETY PRECAUTIONS	4
MACHINE COMPONENTS	5
MACHINE OPERATING INSTRUCTIONS	6
MACHINE MAINTENANCE & STORAGE	6
HANDLE RELEASE ASSEMBLY INSTRUCTIONS	7
PARTS LIST	8-13
WEAR & TEAR PARTS LIST	13
SOLUTION TANK ASSEMBLY(OPTIONAL)	14-15
SPECIFICATIONS	16
WIRING DIAGRAM	16

SAFETY PRECAUTIONS



Carefully read and understand this manual before operating this machine.
This machine must be grounded!

This floor/finishing machine shall be grounded while in use to protect the operator from electric shock. Grounding provides a path of least resistance for electric current. This machine is equipped with a cord having an equipment-grounding conductor and grounding plug. The plug must be plugged into an appropriate outlet that is properly installed and grounded in accordance with all local codes and ordinances. Do not remove the ground pin under any circumstances.

This machine is for use on a nominal 120-volt circuit and has a grounding plug that resembles the plug illustrated in Figure. Make sure that the machine is connected to an outlet having the same configuration as the plug. No adapter should be used with this machine.

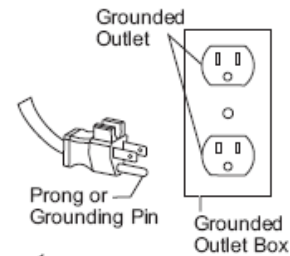

This machine is intended for commercial use. It is constructed for use in an indoor environment and is not intended for any other use. Use only recommended accessories.

1. Do not operate machine:

- Unless trained and authorized.
- In flammable or explosive areas.
- With a damaged cord or plug
- If not in proper operating condition.
- Unless you have read and understand the operators manual.
- With the use of extension cords.
- In outdoor areas and standing water.

2. Before operating machine:

- Make sure all safety devices are in place and operating properly.

3. When using machine:

- Do not run machine over cord.
- Do not pull cord around sharp edges or corners.
- Do not handle plug with wet hands.
- Report machine damage or faulty operation immediately.
- Do not pull machine by cord or plug.
- Do not unplug by pulling on the cord.
- Do not stretch cord.
- Keep cord away from heated surfaces.



When moving, repairing and tilting the machine, make sure the safety installation is right place and tighten the release handle.

4. Before leaving or servicing machine:

- Turn off machine.
- Unplug cord from outlet.

5. When servicing machine:

- Unplug cord from outlet.
- Use manufacturer supplied or approved replacement parts.



To avoid electrical shock, please replace the power cord immediately if any damage is being detected. The replacement must be performed only by an authorized person or by our customer service center.

MACHINE COMPONENTS

Machine Description

- New structure design
- 17" Or 20" Deck aluminum
- 16" or 19" Pad Driver
- Triple Planetary All Steel Gear Box
- Universal Clutch Plate
- Safety Lock-Out Switch
- Security protection in an upright
- 50' Cord
- 66-Frame Motor

Machine Structure

- | | |
|------------------------|---------------------------|
| 1. Deck | 2. Wheel |
| 3. Safety installation | 4. Level Solution |
| 5. Trigger | 6. Safety Lock-Out Switch |
| 7. Housing | 8. Handle Release Assy |
| 9. Top Cover | 10. Motor |
| 11. Clutch Plate | |

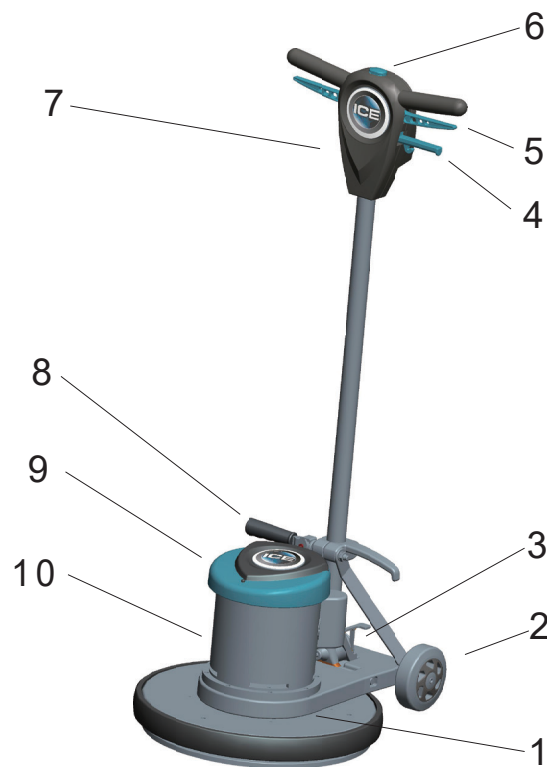
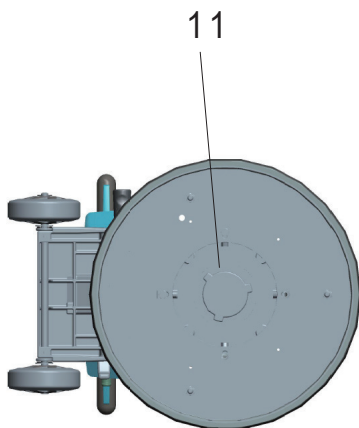

FLOOR MACHINE OPERATING INSTRUCTIONS

General Use:

- 1) Remove any obstructions or other obstacles in the area which is to be cleaned.
- 2) Make sure the safety installation is right place and tighten the release handle.
- 3) Place handle in upright position and tilt machine back until handle rests on the floor.



Be sure the machine is not plugged into an outlet.

- 4) Remove the pad center gripping device by unscrewing the thumbscrews.
- 5) Place appropriate burnishing pad on pad driver and re-attach the center gripping device.
- 6) Place machine back into its upright position.
- 7) Plug power cord into grounded outlet.



Do not use an extension cord in conjunction with the standard power cord.

- 8) Release the compression handle and adjust handle height to a comfortable operating position, then push back down on the compression handle to lock the handle in operating position.
- 9) To start the machine, push on the Blue safety button of the top of upper switch housing and squeeze either of the switch levers.
- 10) When the machine is in operation, both hands should be placed on the handle (switch housing).
- 11) To stop the machine at any time, simply release the switch lever, and the machine will stop automatically.

MAINTENANCE

To keep the machine performing well for many years, please follow the following maintenance procedures.



Always confirm that the machine is unplugged prior to performing any maintenance or repairs.

1. Unplug machine as soon as you are done using it.
2. Make sure the safety installation is right place and tighten the release handle.
3. Tilt machine back and remove pad driver or brush.



Never store a low speed machine with the pad driver or brush mounted to the machine.

4. Clean the outside of the machine with a mild cleaner.
5. Check power cord for any damage. If damage is detected, replace power cord immediately.
6. Lubricate wheels with a water resistant lubricant once a month.
7. Check machine for loose or missing nuts and bolts, and replace as necessary.
8. If the machine is used in a dusty environment, you may remove the motor cover and blow the motor clean with compressed air. This will ensure proper ventilation, and allow the motor to run cooler.

STORAGE

- 1) Unplug machine from power source and wrap cord on handle.
- 2) Tilt machine back and remove pad driver or brush.
- 3) Store in upright position in a dry area.

HANDLE RELEASE ASSEMBLY INSTRUCTIONS

Step 2

- 1) Assemble handle and handle release assembly: According to in the following photos direction assembly.
- 2) Adjust the nylon lock nut: It don't over tighten nylon lock nut, only tighten it enough to hold handle in place when compression lever is in down position.

Step 3

- 1) Connect power cords together

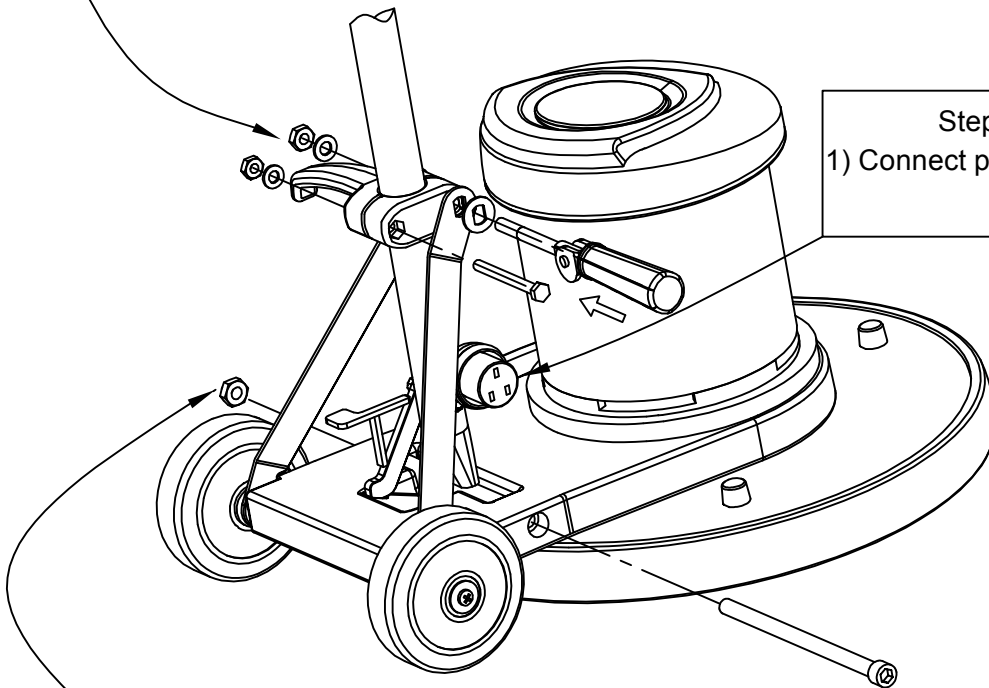

Step 1

- 1) Take out the handle assembly, nut lock M12, hex. socket head M12x210.
- 2) After Aligning them, and use spanner to tighten them.

iP17 & iP20 HANDLE ASSEMBLY

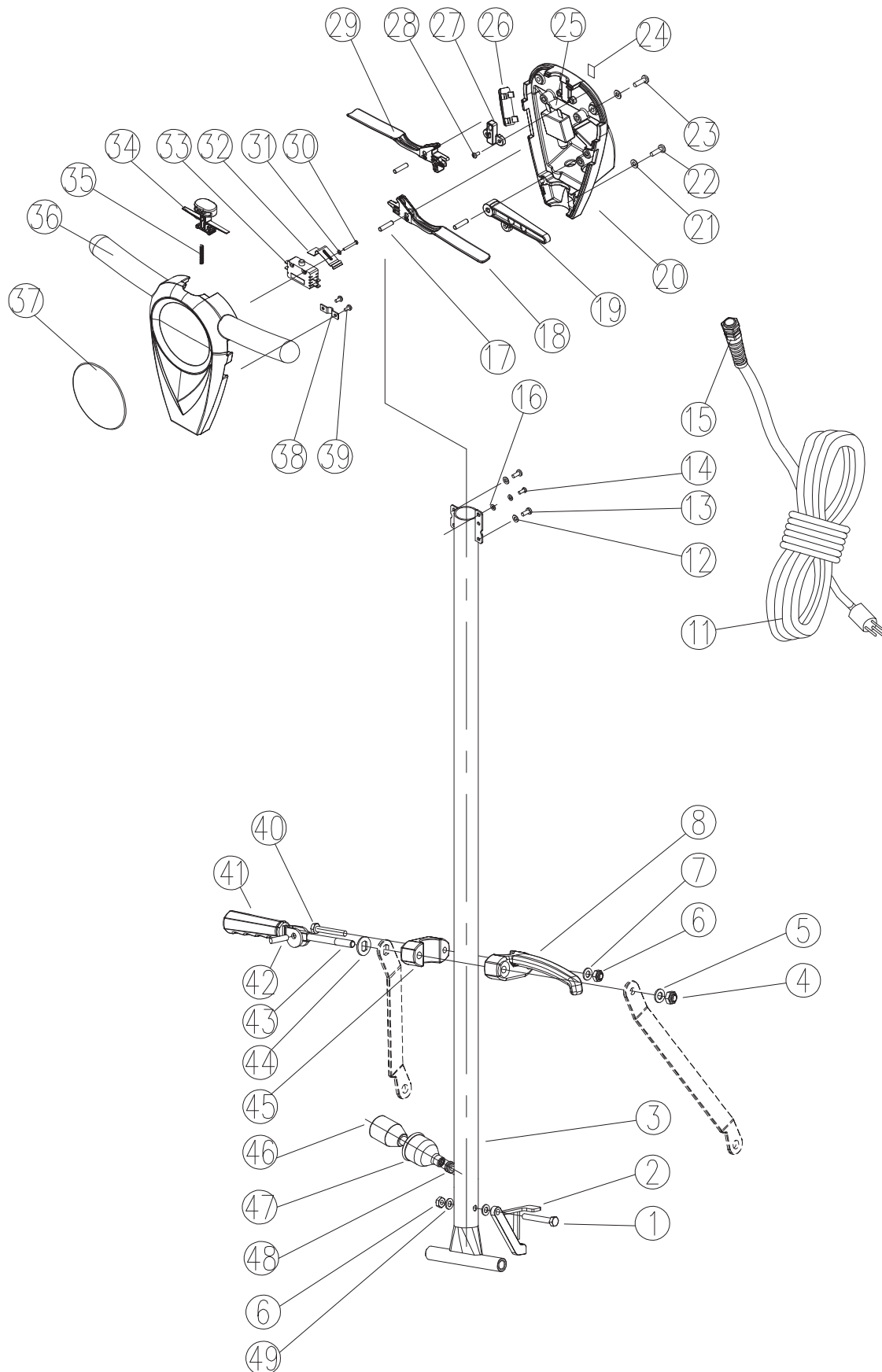

IP17 & IP20 HANDLE ASSEMBLY

DIA NO	PART NUMBER	DESCRIPTION	NO REQ'D
1	1021855	SCREW M8X55	1
2	4313113	BRACKET	1
3	4310120	TUBING	1
4	1123012	NUT LOCK M10	1
5	1421020	WASHER PLAIN Ø10.5XØ20X2	1
6	1123810	NUT LOCK M8	2
7	1421816	WASHER PLAIN Ø8XØ16.5X1.0	1
8	4313101	HOOK CABLE	1
9	4010403	CLAMP TANK	2
10	1511540	SCREW M5 X 40 HEX SOCKET	2
11	4010320	CORD POWER SUPPLY	1
12	1434500	TOOTH WASHER Ø5	4
13	1211512	SCREW M5X12	4
14	1221412	SCREW M4X12	1
15	4020310	STRAIN RELIEF CORD	1
16	1434400	TOOTH WASHER Ø4	2
17	4010314	PIN	3
18	4010331	LEFT TRIGGER SWITCH	1
19	4010305	LEVEL SOLUTION	1
20	4010312	REAR COVER	1
21	1421616	WASHER PLAIN Ø6	4
22	1512635	SCREW M6 X 35	2
23	1512625	SCREW M6 X 25	2
24	4020105	SERIAL NUMBER[IP17]	1
	4010313U	SERIAL NUMBER[IP20]	1
25	5013009	CIRCUIT BREAKER 20A	1
26	4310008	COVER	1
27	4010317	BALL BASE	1
28	1211408	SCREW M4X8	2
29	4010330	RIGHT TRIGGER SWITCH	1
30	1211325	SCREW M3X25	2
31	1434300	TOOTH WASHER	2
32	4010323	SPRING SAFETY	1
33	4010308	SWITCH	1
34	4010307	SAFETY BOTTOM	1
35	4010333	SAFETY SPRING	1
36	4010301	FRONT COVER	1
37	4010316	ICE LOGO	1
38	4010311	CLAMP CORE	1

iP17 & iP20 HANDLE ASSEMBLY

39	1221406	SCREW M4X6	2
40	1031860	SCREW M8X60	1
41	4313111	HANDLE RELEASE	1
42	1647825	PIN Ø8X25	1
43	4313104	VOLT HANDLE RELEASE	1
44	4313103	WASHER PLAIN HANDLE RELEASE	1
45	4313102	COVER HOOK HANDLE	1
46	4010215	CORD HANDLE	1
47	4010120	PLUG PROTECTOR COVER	1
48	4010213	GROMMET	1
49	6311003	WASHER NYLON PLAIN Ø8	2

iP17 & iP20 BASE ASSEMBLY

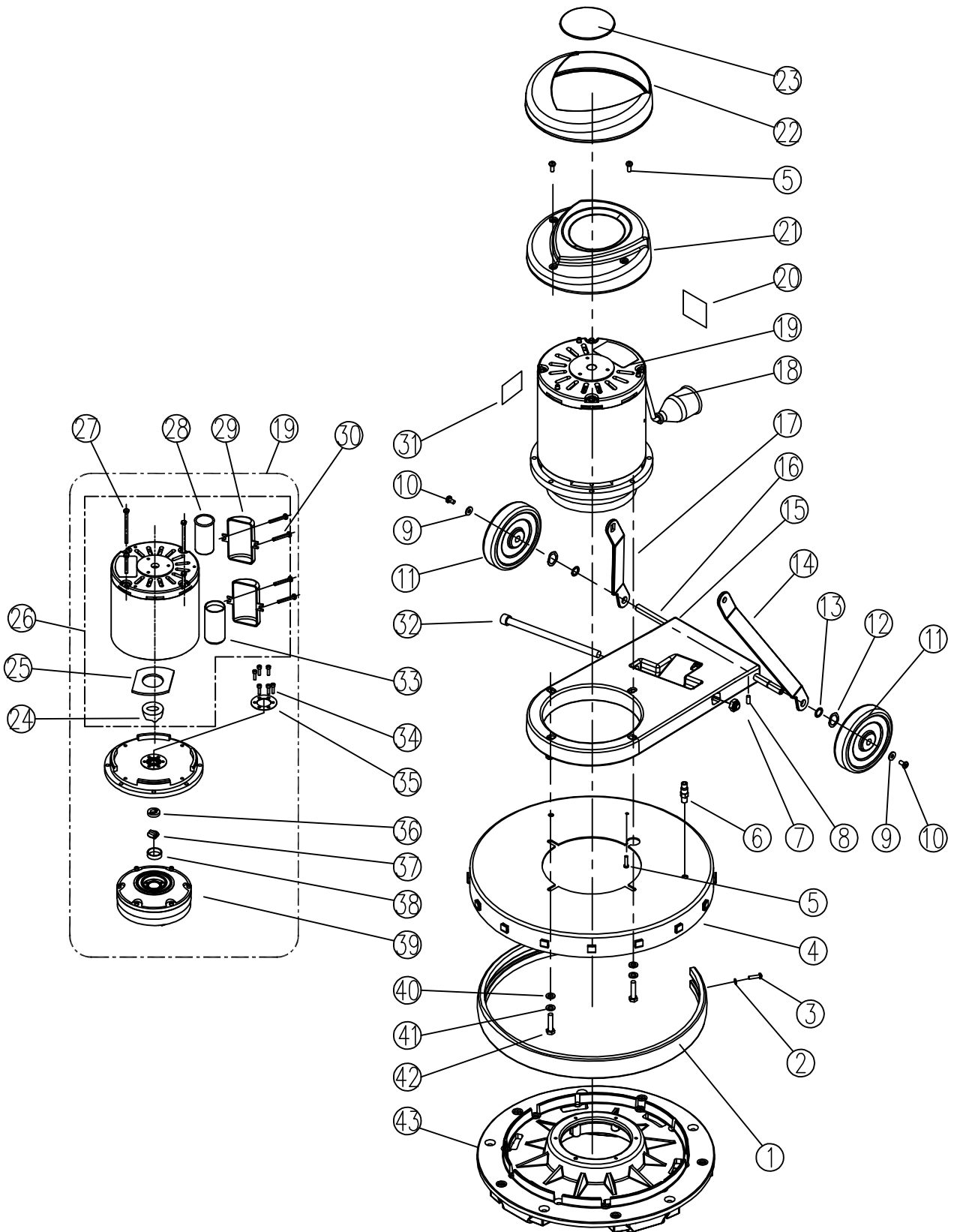

iP17 & iP20 BASE GROUP

DIA NO	PART NUMBER	DESCRIPTION	NO REQ'D
1	4020102	BUMPER 17" [iP17]	1
	4040102	BUMPER 20" [iP20]	1
2	1421510	WASHER PLAIN Ø5	4
3	1221514	SCREW M5X14 PH	2
4	4020101	FRAME 17" [iP17]	1
	4040101	FRAME 20" [iP20]	1
5	1221512	SCREW M5X12 PH	5
6	4010116	BARB HOSE	1
7	1123115	NUT LOCK M12	1
8	1534608	SCREW M6 X 8	2
9	1421618	WASHER PLAIN Ø6.4XØ18X1.6	2
10	4010111	SCREW M6 X 12.7	2
11	4210116	WHEEL 5"	2
12	1435012	WASHER LOCK Ø12	2
13	1421625	WASHER Ø12.5XØ25X1.5	2
14	4313107	BRACKET LEFT	1
15	4310301	ALUMMINIUM BASE MOTOR	1
16	4310302	AXLE	1
17	4313108	BRACKET RIGTH	1
18	4010118	PLUG PROTECTOR	1
19	4021800	MOTOR WITH GEAR BOX	1
20	4010115	READ MANUAL LABEL	1
21	4010102	COVER MOTOR	1
22	4010103	COVER TOP	1
23	4010316	LOGO ICE	1
24	4011813	CENTRIFUGAL SWITCH	1
25	4011812	CENTRIFUGAL SWITCH BOTTOM PLATE COMPONENTS	1
26	4021804	MOTOR 120V	1
27	4011803	BOLT WITH WASHER KIT	4
28	4021802	START-UP CAPACITOR(BIG) 460-530µF/300V	1
29	4011814	COVER CAPACITOR	2
30	1224409	SCREW 8-32UNCX10	4
31	4021803	MOTOR LABEL	1
32	1511221	HEX SOCKET HEAD M12 X 210	1
33	4021801	RUNNING CAPACITOR 60µF/250V	1

iP17 & iP20 BASE GROUP

DIA NO	PART NUMBER	DESCRIPTION	NO REQ'D
34	1531530	SCREW 10-32X25.4	6
35	4011804	BIG WASHER	1
36	4011805	RING GUARD	1
37	4011806	COULPING	1
38	4011807	SLEEVE	1
39	4011809	GEAR BOX	1
40	1421824	WASHER PLAIN Ø8	4
41	1422821	WASHER LOCK Ø8	4
42	1021855	SCREW M8X55	4
43	9010016	16"PAD HOLDER ASSY [iP17]	1
	9010019	19"PAD HOLDER ASSY [iP20]	1

WEAR & TEAR PARTS LIST

DIA NO	PART NUMBER	DESCRIPTION	NO REQ'D	MACHINE
1	4210116	WHEEL 5"	2	iP17&iP20
2	9010019	19"PAD HOLDER ASSY	1	iP20
	9010016	16"PAD HOLDER ASSY	1	iP17

iP17 iP20 SOLUTION TANK ASSEMBLY(OPTIONAL)

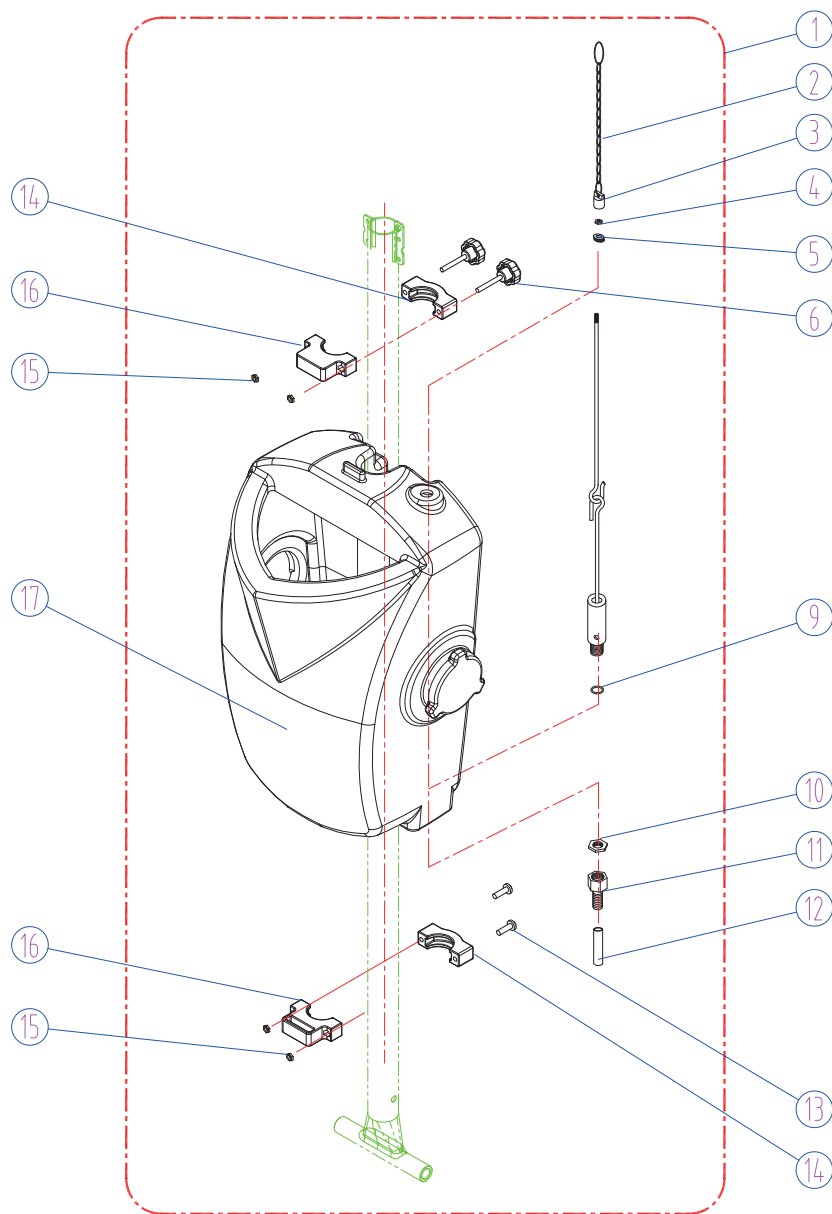

iP17 & iP20 SOLUTION TANK ASSEMBLY

DIA NO	PART NUMBER	DESCRIPTION	NO REQ'D
1	4015000U	SOLUTION TANK ASSEMBLY(OPTIONAL)	1
2	4010423	CHAIN	1
3	4010419	SEAT,CHAIN	1
4	4010412	SCREW,M5,BRASS	1
5	4010418	SEAL,TANK	1
6	4010404	KNOB,M5X40	2
9	4010429	SEAL	1
10	4010426	NUT,1/2-20UNF	1
11	4010425	BARB,HOSE,SOLUTION	1
12	4010406	BARB HOSE	1
13	1511540	SCREW,M5X40,HEX SOCKET	2
14	4010403	CLAMP,TANK	2
15	1113507	NUT,LOCK,M5	4
16	4010402	CLAMP,HOOK	2
17	4010401	TANK	1

SPECIFICATION

Model	iP17	iP20
Voltage	120 V	120 V
Power	1.5HP	1.5HP
Current	13 A	13 A
Frequency	60 Hz	60 Hz
Speed	175 rpm	175 rpm
Deck Size	17" (43 cm)	20" (50 cm)
Length of power cord	15 m	15 m
Weight	44.5 Kg	45 Kg
Dimension LXWXH	56X43X112 cm	57X45X112 cm

Wiring Diagram

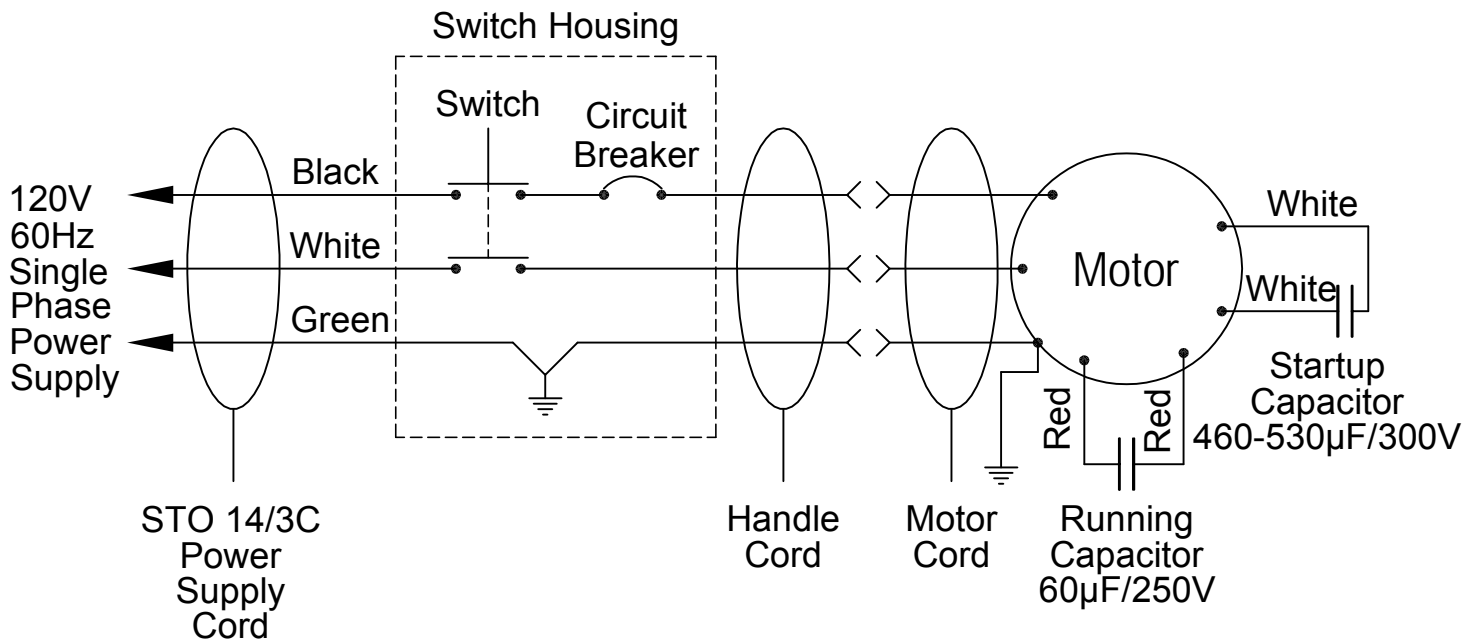

CERTIFICATE OF QUALIFIED

MODEL: _____ SERIAL NO.: _____

INSPECTOR: _____ DATE: _____

ICE Cobotics (GuangDong) Company Limited

TEL:(+86) 769 8186 9000 FAX:(+86) 769 8186 3000