

ICE COBOTICS

WWW.ICE4USA.COM



User Manual

Rider Auto Scrubber



RS20

8630927
REV.01 (07-2023)

INTELLIGENT CLEANING EQUIPMENT



READ OPERATOR MANUAL CAREFULLY!

IMPORTANT: To ensure full warranty protection, please fill out & return your warranty card.

Please fill out at time of installation for future reference.

Model No. _____

Serial No. _____

Machine Options _____

Sales Rep. _____

Sales Rep. Phone No. _____

Customer ID Number _____

Installation Date _____

HOW TO ORDER PARTS

Only use ICE COBOTICS Company supplied or equivalent parts. Parts and supplies may be ordered from your local dealer.

1. Identify the machine model.
2. Identify the machine serial number from the data label.
3. Ensure the proper serial number is used from the parts list.
4. Identify the part number and quantity.
Do not order by page or reference numbers.
5. Provide your name, company name, customer ID number, billing and shipping address, phone number and purchase order number.



PROTECT THE ENVIRONMENT

Please dispose of packaging materials, old machine components such as batteries, hazardous fluids, including antifreeze and oil, in an environmentally safe way according to local waste disposal regulations.



Always remember to recycle.

ICE USA

4242 58th Street | Holland, MI 49423

616-928-6610

ICE4USA.com

Specifications and parts are subject to change without notice.

TABLE OF CONTENTS

SAFETY PRECAUTIONS.....	3
MACHINE COMPONENTS.....	4-5
MACHINE SETUP & INSTALLATION.....	6
MACHINE OPERATION.....	7
WHILE OPERATING MACHINE.....	8
TANK DRAINING.....	9
BATTERY CHARGING.....	9
BATTERY USE.....	9
PREVENTATIVE MAINTENANCE.....	10
FAULT CODE AND ELIMINATE.....	11-12
TECHNICAL SPECIFICATIONS.....	13
WEAR AND TEAR PARTS.....	14
WIRING DIAGRAM.....	15

SAFETY PRECAUTIONS

This machine is intended for commercial use. It is designed exclusively to scrub hard floors in an indoor environment and is not constructed for any other use. Only use recommended accessories.

All operators shall read, understand and exercise the following safety precautions:

1. Do not operate machine:

- Unless trained and authorized.
- Unless you have read and understand the operators manual.
- In flammable or explosive areas.
- If not in proper operating condition.

2. Before starting machine:

- Make sure all safety devices are in place and operate properly.
- Check brakes and steering for proper operation.

3. When using machine:

- Go slow on inclines and slippery surfaces.
- Follow all safety guidelines.
- Be very careful when using the machine in reverse.
- Reduce speed when turning.
- Report and fix any damage to machine prior to operating it.
- Never allow children to play on or around.

4. Before leaving or servicing machine:

- Stop on level surface.
- Turn off machine.

5. When servicing machine:

- Read operators manual thoroughly prior to operating or servicing this machine.
- Use manufacturer supplied or approved replacement parts.
- Secure machine with wheel blocks prior to jacking the machine up.
- Use approved jack or hoist to safely elevate the machine.
- Disconnect batteries prior to working on machine.
- Avoid moving parts. Do not wear loose fitting clothing while servicing machine.

 **WARNING: The machine is not intended for use by persons (including children) with reduced physical, sensory or mental capabilities, or lack of experience and knowledge.**

- Children should be supervised to ensure that they do not play with the appliance.
- Cleaning and user maintenance shall not be made by children without supervision.
- WARNING Operators shall be adequately instructed on the use of these machines.
- CAUTION This machine shall be stored indoors only.
- Power the machine OFF at the power switch, before changing the brushes, or other attachments.
- The disposal of the batteries should be safely done in accordance with your local environmental regulations.
- Wear the appropriate personal protective equipment such as gloves and eye protection when handling floor cleaning detergents.
- If the supply cord is damaged, it must be replaced by the manufacturer, its service agent, or similarly qualified persons in order to avoid a hazard.
- Do not use for cleaning purposes on surfaces having a gradient exceeding that marked on the machine.

 **WARNING: Please do not operate the machine on slope which is exceeding 17% in case of rollover.**

- Please sit straight in case of rollover while driving.
- Please do not stop or turning around on slope in case of rollover.
- Please drive slowly when you are trying to make turn.

 **WARNING: Explosion or fire can result from hydrogen gas. Keep sparks and open flames away! Keep battery compartment open when charging.**

 **WARNING: Flammable materials can cause an explosion or fire. Do not use flammable materials in tanks.**

 **WARNING: Flammable materials or reactive metals can cause explosion or fire. Do not pick up.**

MACHINE COMPONENTS

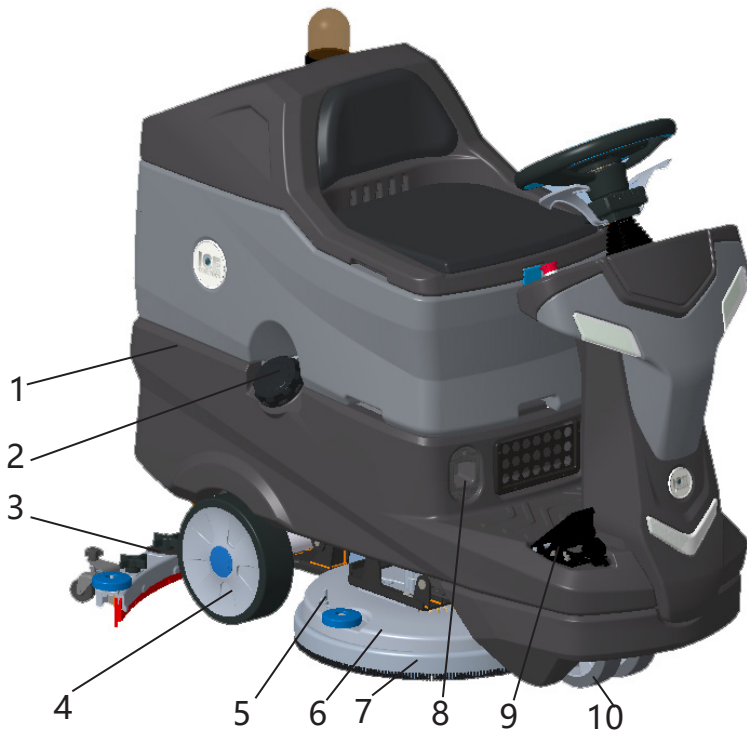

- 1. Solution tank
- 2. Cap for hose fill port
- 3. Squeegee assembly
- 4. 10" Non marking rear wheels
- 5. Pad release plunger
- 6. Scrub head assembly
- 7. Splash guard
- 8. On-board charger status window
- 9. Propel pedal
- 10. 8" Non marking front wheels

- 11. Back cushion
- 12. Seat cushion
- 13. LED display screen
- 14. Steering wheel
- 15. Horn switch
- 16. Emergency stop switch
- 17. Front safety lights
- 18. V front safety lights
- 19. Start switch
- 20. Mesh, Battery charger power cord
- 21. Buckle
- 22. Detergent bottle
- 23. Recovery tank
- 24. Recovery tank cover
- 25. Warning light

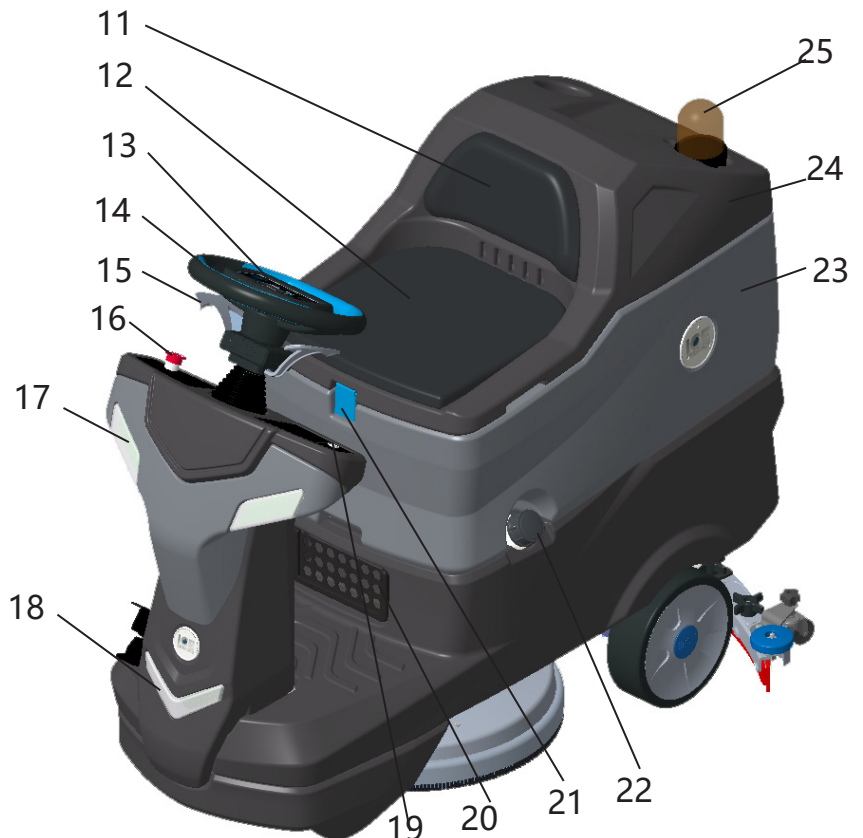

MACHINE COMPONENTS



- 26. Direction button
- 27. ECO display
- 28. Direction display
- 29. Timer
- 30. Detergent adjusting display
- 31. Signal
- 32. Battery meter
- 33. Vacuum motor display
- 34. Solution flow adjusting display
- 35. 1-Step starting button
- 36. ECO Button
- 37. Detergent adjusting button
- 38. Solution flow adjusting button
- 39. Vacuum motor starting button

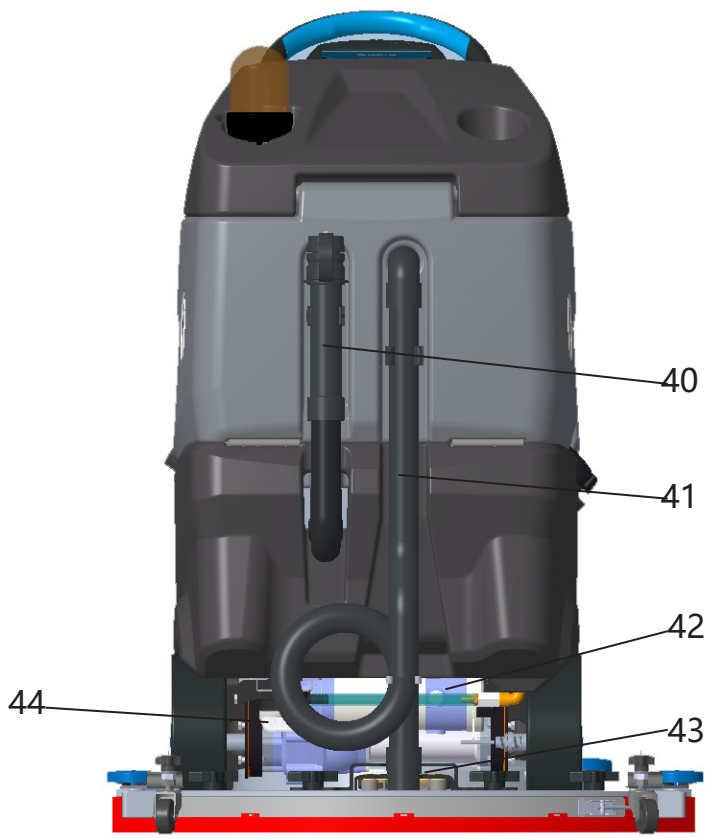

- 40. Drain hose, recovery tank
- 41. Vacuum hose
- 42. Drive motor
- 43. Adjusting knob, Squeegee
- 44. Filter assembly,
Solution tank drain

MACHINE SET UP & INSTALLATION

UNCRATING MACHINE

Be sure and check packing carton for any damage. Immediately report any damage to carrier. Check the contents of package to ensure that the following items are included:

- Machine
 - Lithium-ion Batteries
 - Squeegee assembly
 - 1-Pad driver
 - 1-Brush
1. Uncrate the wooden box, place the top board on the edge of pallet, lie in the front of the machine, as below shown.

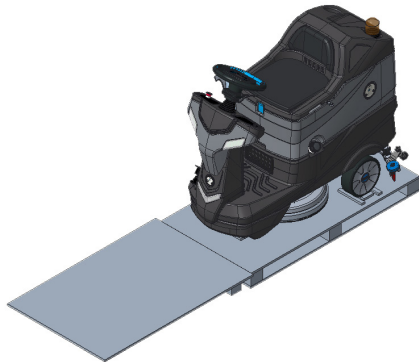

! WARNING: Do not operate machine unless you have read & understood this manual.

2. Install batteries.(see *INSTALLING BATTERIES*)
3. Press and hold the one-key start switch for 3 seconds (machine components, #19) to turn on the machine, make sure the Squeegee assembly (machine components, #3) and the Scrub head assembly (machine components, #6) is off the floor.
4. Sit in the Operator seat (machine components, #12), hold the Steering wheel (machine components, #14), press the Propel pedal (machine components, #9) and driving slowly the machine down from the slope.

INSTALLING BATTERIES

The machine uses the Lithium-ion batteries, the batteries are already in the machine upon delivery; However you will need to connect the Lithium ion batteries to the machine.

! WARNING: Fire or Explosion Hazard. Keep sparks and open flames away! Keep battery compartment open when charging.

1. Turn off the machine.
2. Open and prop up the Operator seat, plug the batteries connector to the machine adaptor, connect machine green port to the batteries.

MACHINE SET UP

INSTALLING BRUSHES OR PADS

1. Turn off the 1-Step switch (machine components, #35) and raise the Scrub head assembly off the floor, then stop machine on the level surface, ensure the machine is turned off.
2. If using the pad driver, first attach the appropriate pad to the pad driver surface.
3. Align the pad driver or brush under the motor hub and push it magnetically attracted.



4. To remove the pad driver or brush, raise the scrub head and remove the Side squeegee assembly (machine components, #7), Press down on pad release plunger(machine components, #5), push the edge of brush downward.

MOUNTING THE SQUEEGEE ASSEMBLY

1. Turn off the 1-Step switch and raise the Squeegee assembly off the floor.
2. Mount the squeegee assembly to the squeegee pivot bracket. make sure the knobs are completely seated into the slots before securing knobs.
3. Connect the Vacuum hose (machine components, #41) to the squeegee assembly. Loop the hose by using the hose clip provided.
4. Check the squeegee blades for proper adjustment.

FILLING THE SOLUTION TANK

At the side has a water injection port.

NOTE: Before accessing the bucket fill-port make sure that the recovery tank is empty. When filling the solution tank with a bucket, make sure that the bucket is clean. Do not use the same bucket for filling and draining the machine.

OPERATOR MANUAL

 **WARNING:** Do not put any flammable materials into solution tank. this can cause an explosion or a fire.

FILLING THE DETERGENT BOTTLE

The machine is equipped with a 4 liters Detergent bottle (machine components, #22). Open the Cap (machine components, #22) you can fill detergent.

The ratio of water and detergent is 0~5%, you can adjust this ratio via pressing the Detergent dosage adjusting buttons (machine components, #37).

water and detergent information as follows:

Water information of RS20			
Water level	1	2	3
Water	500ml/0.13Gal	1000ml/0.26Gal	1500ml/0.40Gal

Water and Detergent information of RS20				
Detergent level	1	2	3	Water level
	4g/0.14oz	8g/0.28oz	12g/0.42oz	1
Detergent	8g/0.28oz	15.5g/0.55oz	23.5g/0.83oz	2
	15.5g/0.55oz	31g/1.09oz	47g/1.66oz	3

NOTE: Only use recommended cleaning chemicals. Contact your janitorial supply distributor for recommendations on proper chemicals.

MACHINE OPERATION

 **WARNING:** Do not operate machine unless you have read and understand this manual.

PRE-OPERATION CHECKS

1. Check the tank cover seals for damage.
2. Drain the recovery tank, check the vacuum fan inlet filter, clean them if necessary.
3. Check the vacuum hose for debris or blockage.
4. Check the squeegees for damage, wear and for deflection adjustment.
5. Check whether Pad/Brush is installed properly .
6. Check the accelerator and steering for proper operation.

OPERATION THE MACHINE

1. Automatic unlocking of seat self-locking safety switch.
NOTE: The machine will not travel unless the operator is sitting in the operator seat.
2. After long press the start switch (machine component #19) for 3 seconds, after the screen lights up, long press the forward/back button (machine component #26) and one-click start (machine component #35) at the same time for 3 seconds to complete the boot. check the display(machine components, #13) , if there are fault codes and the Fault indicator and blinks, is blink, please Do Not operation the machine unless the faults have been eliminated (please see *FAULT CODES AND ELIMINATE* section).
3. Select a suitable working mode by selecting the working mode button. This the machine has two modes of operation: ECO energy saving, and user-defined mode.

NOTE: To energy saving, recommend to using the ECO mode as possible.

- For the User custom mode, you can select the preferred settings by pressing the Solution flow adjusting button (Machine components,#38), Detergent adjusting button (Machine components, #37), select the appropriate parameters to work with.
4. Turn on the 1-Step switch, the Scrub head assembly and the Squeegee assembly will lower down automatically, all the presetting functions will turn on.
 5. The machine can scrub in both forward and backward, press the Directional button (Machine components, #26) to select the direction. The horn will sound and the squeegee will raise automatically (the vacuum motor will turn off after a short delay) when drive machine backwards. This is to prevents damaging the squeegee.
NOTE: Go slow when drive machine backwards.
 6. The machine can implement a single brush without suction working mode by pressing a key After the start button (machine component #35), press the suction pump switch Button (machine component #39) to turn off suction pump. When the machine is working backward, the wiper assembly will automatically rise to avoid damage Bad scratch, buzzer alarm.

7. Press the Propel pedal, the machine start scrubbing, the speed can be adjusted by controlling the force of foot stepping, light is slow, heavy is fast.

NOTE: Go slow on inclines and slippery surfaces.

8. To stop scrubbing, turn off the 1-Step switch, the scrub head will raise automatically, the squeegee will also raise after a short delay (the vacuum indicator flashing), please keep moving until the dirty water is picked up, and then release the propel pedal and stop scrubbing.
9. Hold down the 1-button start switch for 3 seconds to turn off the power supply of the machine.
10. If the machine stops working, it will automatically shut down after standing still for 12 minutes.

BRAKE DEVICE

The machine is driven by the rear wheel (machine component #11), on the rear drive wheel, There's an electromagnetic brake. When the operator releases the drive pedal, the machine Will stop the progress, the electromagnetic brake after a moment of delay, automatically brake the rear Drive wheels, parking brakes.

EMERGENCY STOP BUTTON

The machine is equipped with an Emergency stop button (machine components, #17), please push it if an emergency, that will shut off all power of machine and brake immediately.

To restart the machine, please reset the Emergency stop button, and turn off the machine and then restart.

NOTE: Please hold the steering wheel when emergency stop.

WHILE OPERATING MACHINE

! WARNING: Fire Or Explosion Hazard. Do Not Pick Up Flammable Materials Or Reactive Metals.

1. Go slow on inclines and slippery surfaces, go slow when turn and reverse. Do not operate the machine on inclines that exceed 7% (4°).
2. Drive machine in a straight path as possible, avoid turning the Steering wheel too sharply when machine is in motion.
3. Do not keep the machine in the same position with pad / brush spinning, keep the machine moving to prevent damage to floor finish.
4. If the squeegee assembly leaves streaks on the floor, raise the squeegee off the floor and wipe the blades down with a damp cloth. Pre-sweep the area to prevent leaving streaks on the floor.

5. To obtain the optimum cleaning performance, you can adjust the solution flow and detergent dosage as your required. If poor picking up water performance is observed, please stop scrubbing and check the squeegee blade, adjust or replace if necessary.
6. If the dirty water path exceed the width of squeegee, please adjust the side squeegee assembly.
7. Pour a recommended defoamer into the recovery tank if excessive foam appears.

! WARNING: The foam do not activate water level switch, excessive foam may result in vacuum motor damage.

8. Press the Horn button (machine components, #15) to alert if necessary .
9. The machine is equipped with a Warning light (machine components, #25), remind pedestrians to avoid the road.
10. If there is a fault code on the LED display screen, the machine will stop scrubbing and alarm, troubleshoot (see Troubleshooting) before using the machine.
11. For very dirty floors, select the switch by working mode single brush non-suction working mode is selected.
12. If you only want to pick up water needn't scrubbing, Turn on the Vacuum motor switch (squeegee will lower down) and turn off the 1-Step switch (if it is ON), the scrub head will raise and then start to working.

! WARNING: While driving, do not make sharp turn in case of rollover.

- The device is equipped with a turning angle sensor which will slow down the running speed if it detects that you are making turn or turning around.
- Please drive slowly when you are trying to make turn.

! WARNING: Please do not operate the machine on slope which is exceeding 17% in case of rollover.

- Please sit straight in case of rollover while driving.
- Please do not stop or turning around on slope in case of rollover.

OPERATOR MANUAL

TANK DRAINING

DRAINING THE RECOVERY TANK

Any time scrubbing is completed, or when refilling solution tank, the recovery tank should be drained and cleaned.

⚠ WARNING: If the recovery tank is not drained when the solution tank has been refilled, foam or water may enter the float shut-off screen and cause damage to the vacuum motor.

1. While holding the Recovery tank drain hose (machine components, #40) upward, remove the cap and lower hose to drain.
2. Open the Recovery tank cover (machine components, #24) and rinse out the tank. Use a rag to remove any excess dirt.
3. Remove and clean the vacuum fan inlet filter located in the recovery tank. Clean the filter with a damp cloth or low pressure water hose if dirty. Allow the vacuum fan filter to dry completely before reinstalling it in the machine.

DRAINING THE SOLUTION TANK

Any time scrubbing operation is completed, the solution tank should be drained and cleaned.

1. Unscrew filter cover (machine assembly #45) and let clean water tank discharge.
2. Rinse the solution tank with clean water after every use. This will help prevent chemical buildup and clogging of the solution lines.

BATTERY CHARGING

⚠ WARNING: Fire Or Explosion Hazard. Keep Sparks and Open Flame Away. Keep Battery Compartment Propped Open When Charging.

Use only ICE COBOTICS supplied or approved batteries charger, use unapproved charger may cause damage to the batteries and machine.

Lithium-ion battery must be stored in a charged state, please charge monthly.

Batteries charger specifications:

- Applicable to charging Lithium-ion batteries
- Automatic shut off circuit
- Output current of 15 Amps
- Output voltage of 24 volts

1. Transport the machine to a well ventilated area.
2. Turn the machine off.
3. Please open the sewage tank to maintain ventilation while charging.
4. Connect the charger's AC power supply cord to a properly grounded receptacle.
5. The charger will automatically begin to charge, you can watching the charging status on the window (machine components, #8), once the charging cycle begins, There are 5 green indicators on the charger, the LED1 indicator blinks, indicating that the charging has entered the first stage (less than 20%), the LED2 indicator blinks, indicating that the charging has entered the second stage (20%~40%), the LED3 indicator blinks, indicating that the charging has entered the third stage (40%~60%), the LED4 indicator blinks, and the LED1 indicator blinks. It indicates that the charging enters the fourth stage (60%~80%), the LED5 indicator light flashes, indicating that the charging enters the fifth stage (80%~90%), the LED5 indicator light flashes quickly, indicating that the charging enters the sixth stage (90%~100%), if the LED indicator light blinks quickly in turn, it indicates that the battery is full, unplug the charger, charging is complete.

NOTE: The machine will can not operate when charging.

BATTERY USE

⚠ WARNING: The machine is only to be used with the battery provided by manufacturer.

- Against using non-rechargeable batteries.
- The battery must be removed from the appliance before it is scrapped.
- The machine must be disconnected from the supply mains when removing the battery.
- The battery is to be disposed of safely.
- Safely disconnecting at least the non frame connected pole of the battery or by an equivalent method (disconnecting device);

PREVENTATIVE MAINTENANCE



WARNING: Before performing any maintenance on the machine, be sure that the power is turned off, or the batteries are disconnected!



WARNING: Repairs are to be completed by Authorized service centers only. Any repairs completed by unauthorized persons will void the warranty.

DAILY MAINTENANCE

1. Remove pad driver/ brush and clean with approved cleaner.
2. Drain recovery and solution tanks completely and rinse out with clean water. Visually check the recovery tank for debris and clean out as necessary.
3. Raise the squeegee assembly off floor and wipe it down with a damp towel. Be sure to store the squeegee in the up position.
4. Remove the vacuum fan inlet filter and rinse it out with clean water.
5. Clean machine with an approved cleaner and a damp towel.
6. Recharge the batteries.
7. Check the condition of the squeegee blade wiping edge, rotate blade if worn.

MONTHLY MAINTENANCE

1. Clean the battery tops to prevent corrosion.
2. Check for loose battery cable connections.
3. Inspect and clean the recovery tank cover seal. Replace it if damaged.
4. Lubricate all grease points and pivot points with silicon spray and approved grease.
5. Check the machine for loose nuts and bolts.
6. Check the machine for leaks.
7. Check and clean solution and recovery tank filters.
8. Lithium-ion battery must be stored in a charged state, please charge monthly.

MACHINE STORAGE

1. Always store the machine indoors.
2. Always store the machine in a dry area.
3. Always store the machine in its upright position.
4. Always store the machine with the pad driver/ brush raised off the floor.
5. Always store the machine with the squeegee assembly raised off the floor.
6. If storing in an area which may reach freezing temperatures, be sure to drain all fluids from the machine prior to storage. Any damage caused by freezing temperatures will not be covered by the warranty.
7. Drain the recovery tank.
8. Drain the solution tank of all fluid.

FAULT CODE & SOLUTION

The machine is equipped with a LED display screen (see Machine components, item # 13), the LED screen will display the operating hours (see Machine components, item # 29) and the battery level status (see Machine components, item # 32).

When the machine detects a fault, there will be a Fault code (see Machine components, item #13) & Fault message display on the LED screen, will flash continuously, accompany an audible alarm Occasionally.

Once fault occurring, please DO NOT continue operate the machine unless the fault are eliminated.

Turn off the machine, then to solve the fault, the fault code & message will be eliminated when machine restart.

If the fault is occurred frequently, or the fault can't be eliminated, please contact ICE COBOTICS service center.

Please refer to the below table to determine the fault cause and the solution.

FAULT CODE & SOLUTION

FAULT CODE	FAULT MESSAGE	SOLUTION
A0001	Seat Empty	Sit in seat
A0008	Recovery Tank Full	Drain Recovery tank
A0009	Solution Tank Empty	Refill Solution tank
A0139	Battery Low	Charge battery
A0140	Battery Discharged	Charge battery Immediately
F1495	Brake Asseembly Malfunction	Check brake wiring
A0013	Release Accelerate Pedal	Release the propel pedal
A0002	Emergency Button Pressed	Release Emergency stop button
A1011	Equipment component overload	Pls restart the machine
A0991		
A1131		
A0751		
A0571		
F1496	Equipment Failure	Pls restart the machine or contact service
A0456		
F1422		
F0755		
F1135		
F1316		
F1315		
F0575		
F0016		
F0480		
F0461		
F1276		
F1275		
F0995		
F1015		
F1786		
F1782		
F1646		
F1645		
F1656		
F1655		
F0576		
F0756		
F1136		
F0996		
F1016		
F1296		
F1295		
F1725		

FAULT CODE & SOLUTION

FAULT CODE	FAULT MESSAGE	SOLUTION
F1726	Equipment Failure	Pls restart the machine or contact service
F0474		
F0468		
F0467		
F0466		
A0452		
A0451		
F1635		
F0471		
A0573		
F0587		
A0753		
F0767		
A1134		
F1137		
F0588		
F0768		
F1138		
F0998		
F1018		
F0463		
F0464		
A0453		
A0454		
F0487		
F1942		
F1943		
F1944		

TECHNICAL SPECIFICATIONS

MODEL	RS20
LENGTH	55 in / 1,400 mm
WIDTH (MACHINE WITH SCRUB HEAD)	24.8 in / 630 mm
HEIGHT	47.2 in / 1,200 mm
WEIGHT	419 lbs / 190Kg
WEIGHT WITH BATTERIES	496 lbs / 225 Kg
RECOVERY TANK CAPACITY	17 Gal / 65 L
SOLUTION TANK CAPACITY	15.8 Gal / 60 L
SQUEEGEE WIDTH	33.8 in / 860 mm
CLEANING PATH WIDTH	20 in / 508 mm
PRODUCTIVITY RATE PER HOUR (IN THEORY)	23,681 ft ² 2,800 m ²
TRAVEL SPEED (TRANSPORT)	3.7 Mile / h 6 Km / h
MINIMUM AISLE TURN	63 in / 1,600 mm
PAD/BRUSH PRESSURE	66 lbs / 30 Kg
SOLUTION FLOW	0 ~ 0.4 Gal / Min 0 ~ 1.5 L / Min
BATTERIES	Lithium-ion batteries, 120AH
VOLTAGE	24V DC
DRIVE WHEEL	0.6 hp / 0.45KW
BRUSH MOTOR	0.73 hp / 0.55 KW, 220 RPM
VACUUM MOTOR	0.6 hp / 0.45KW
VACUUM WATER LIFT (MAX)	40 in. H2O / 1020 mm. H2O
RUN TIME PER CHARGE	2.5~3 Hours
DECIBEL RATING AT OPERATOR'S EAR, INDOORS	65 dB(A)
GRADE LEVEL, MAX	Scrubbing: 4°/7% Transporting (empty):10°/17%

WEAR AND TEAR PARTS

DIA NO.	PART NUMBER	DESCRIPTION	NO REQ'D
1	860010	10" WHEEL, PU TIRE	2
2	8115200	8" WHEEL	2
3	8116009	PROTECTIVE WHEEL	3
4	8311531	REAR BLADE, LINATEX	1
5	8311534	FRONT BLADE, LINATEX	1
6	9052020	BRUSH, 20 INCH	1
7	9042020	PAD DRIVER, 20INCH	1

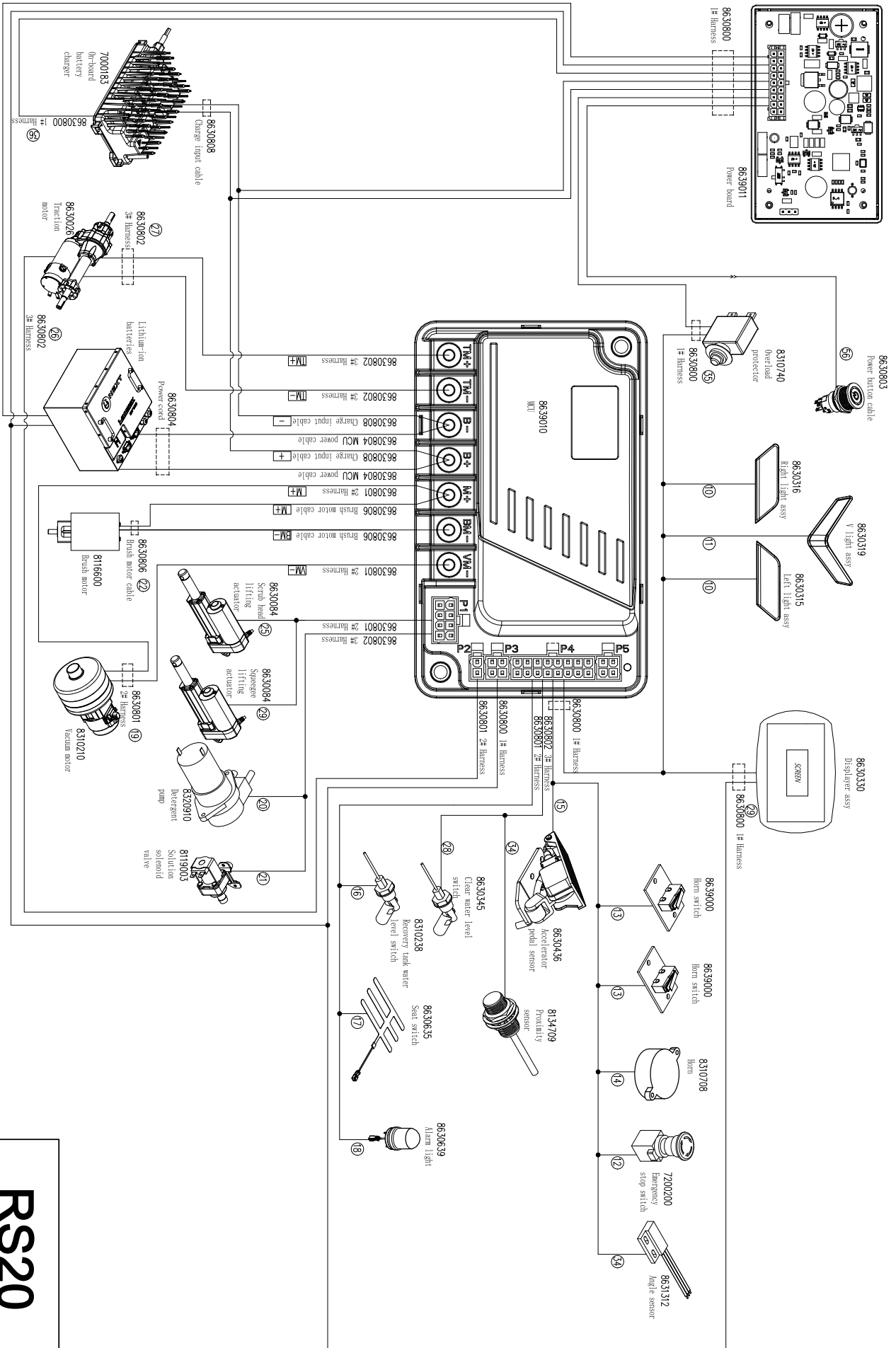

RS20