

ICE USA

A DIVISION OF ICE ROBOTICS

www.ice4usa.com



Operator & Parts Manual

Automatic Scrubber



i28BTL+
i28BTL+-CY
i32BTL+

i-SYNERGY
Cleaning Management in Motion

8210042
REV.05 (06-2023)



READ OPERATOR MANUAL CAREFULLY!

IMPORTANT: To ensure full warranty protection, please fill out & return your warranty card.

Please fill out at time of installation for future reference.

Model No. _____

Serial No. _____

Machine Options _____

Sales Rep. _____

Sales Rep. Phone No. _____

Customer ID Number _____

Installation Date _____

HOW TO ORDER PARTS

Only use ICE Cobotics Company supplied or equivalent parts. Parts and supplies may be ordered online, by phone, by fax or by mail.

1. Identify the machine model.
2. Identify the machine serial number from the data label.
3. Ensure the proper serial number is used from the parts list.
4. Identify the part number and quantity.
Do not order by page or reference numbers.
5. Provide your name, company name, customer ID number, billing and shipping address, phone number and purchase order number.



PROTECT THE ENVIRONMENT

Please dispose of packaging materials, old machine components such as batteries, hazardous fluids, including antifreeze and oil, in an environmentally safe way according to local waste disposal regulations.



Always remember to recycle.

ICE Cobotics (GuangDdong) Company Limited

XiangShi Road LiaoBu DongGuan GuangDong China

Tel: 0769 - 81869000

Fax: 0769 - 81863000

Specifications and parts are subject to change without notice.

TABLE OF CONTENTS

SAFETY PRECAUTIONS.....	4
MACHINE COMPONENTS.....	5
PANEL COMPONENTS.....	6
i-synergy™ INTRODUCTION.....	7
MACHINE SETUP & INSTALLATION.....	7
MACHINE OPERATION.....	8
WHILE OPERATING MACHINE.....	8
TANK DRAINING.....	9
BATTERY CHARGING.....	10
PREVENTATIVE MAINTENANCE.....	10
CYLINDRICAL BRUSH MODEL.....	11
CLINDRICAL ASSEMBLY INSTRUCTIONS.....	12
FAULT CODE & SOLUTION.....	14
BASIC TROUBLESHOOTING.....	15
TECHNICAL SPECIFICATION.....	16
PARTS LIST.....	17-43
TRANSAXLE TERMINAL GROUP.....	44~45
WEAR AND TEAR PARTS.....	46
WIRING DIAGRAM.....	47

SAFETY PRECAUTIONS

This machine is intended for commercial use. It is designed exclusively to scrub hard floors in an indoor environment and is not constructed for any other use. Only use recommended accessories.

All operators shall read, understand and exercise the following safety precautions:

1. Do not operate machine:

- Unless trained and authorized.
- Unless you have read and understand the operators manual.
- In flammable or explosive areas.
- If not in proper operating condition.
- In outdoors areas.

2. Before starting machine:

- Make sure all safety devices are in place and operate properly.

3. When using machine:

- Go slow on inclines and slippery surfaces.
- Follow all safety guidelines.
- Be very careful when using the machine in reverse.
- Reduce speed when turning.
- Report and fix any damage to machine prior to operating it.
- Never allow children to play on or around.
- Do not operate on inclines that exceed 5% (3°).

4. Before leaving or servicing machine:

- Stop on level surface.
- Turn off machine.

5. When servicing machine:

- Read operators manual thoroughly prior to operating or servicing this machine.
- Use manufacturer supplied or approved replacement parts.
- Secure machine with wheel blocks prior to jacking the machine up.
- Use approved jack or hoist to safely elevate the machine.
- Disconnect batteries prior to working on machine.
- Avoid moving parts. Do not wear loose fitting clothing while servicing machine.

 **WARNING: Fire or Explosion Hazard. Keep sparks and open flames away! Keep battery compartment open when charging.**

 **WARNING: Flammable materials can cause an explosion or fire. Do not use flammable materials in tanks.**

 **WARNING: Flammable materials or reactive metals can cause explosion or fire. Do not pick up.**

MACHINE COMPONENTS

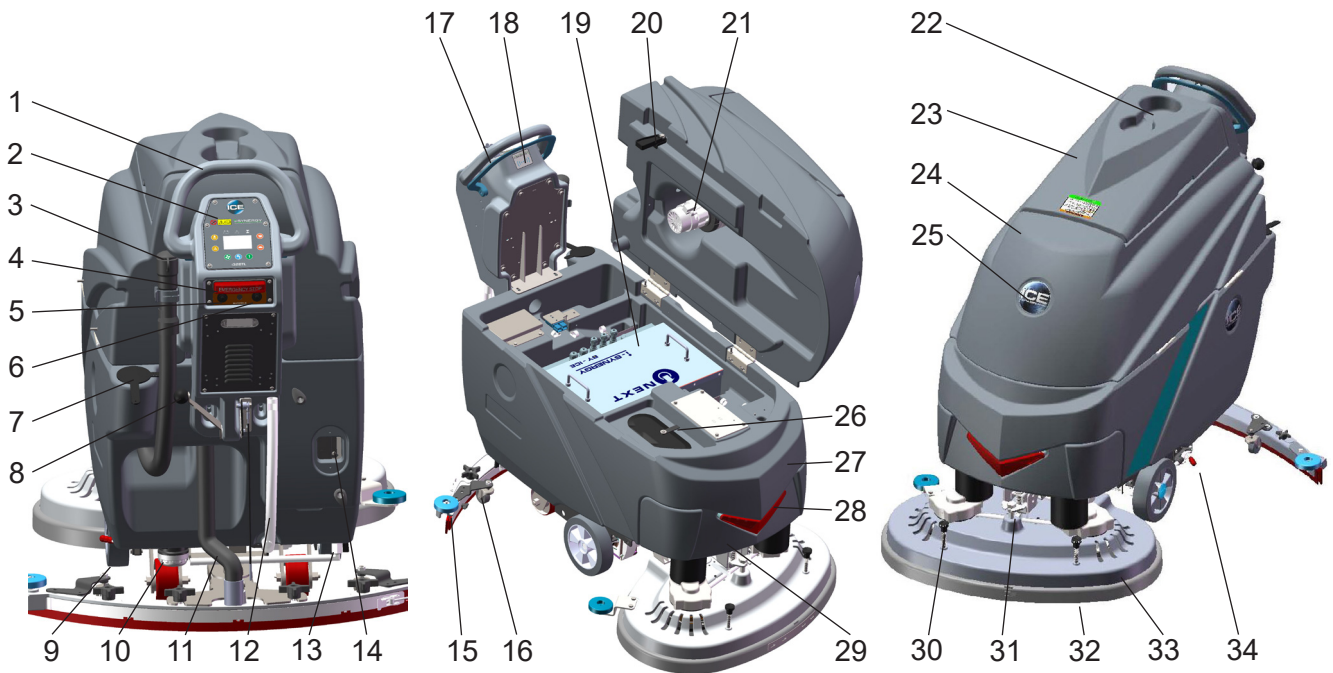

- | | |
|---|--|
| <ol style="list-style-type: none"> 1. Control handle 2. Control panel (See penal components) 3. Recovery tank drain hose 4. Emergency stop button 5. Circuit breaker, Controller 6. Circuit breaker, Brake 7. Hose fill port 8. Squeegee lift lever 9. Wheels, 8 Inch 10. Filter assembly 11. Vacuum hose 12. Solution tank level / Drain hose 13. Ball valve 14. On-board battery charger 15. Squeegee assembly 16. Caster, 2 inch, Squeegee adjustment 17. Control handle start bail | <ol style="list-style-type: none"> 18. i-synergy™, ID card scanning area 19. Lithium-ion batteries 20. Recovery tank support stand 21. Vacuum motor, 24VDC 22. Cup holder 23. Recovery tank cover 24. Recovery tank 25. ICE logo 26. Bucket fill port/ Clean-out port 27. Solution tank 28. LED light 29. Front cover 30. Brush & Pad release plunger 31. Scrub head adjusting bolt 32. Scrub head skirt 33. Scrub head assembly 34. Parking brake (Option) |
|---|--|

PANEL COMPONENTS

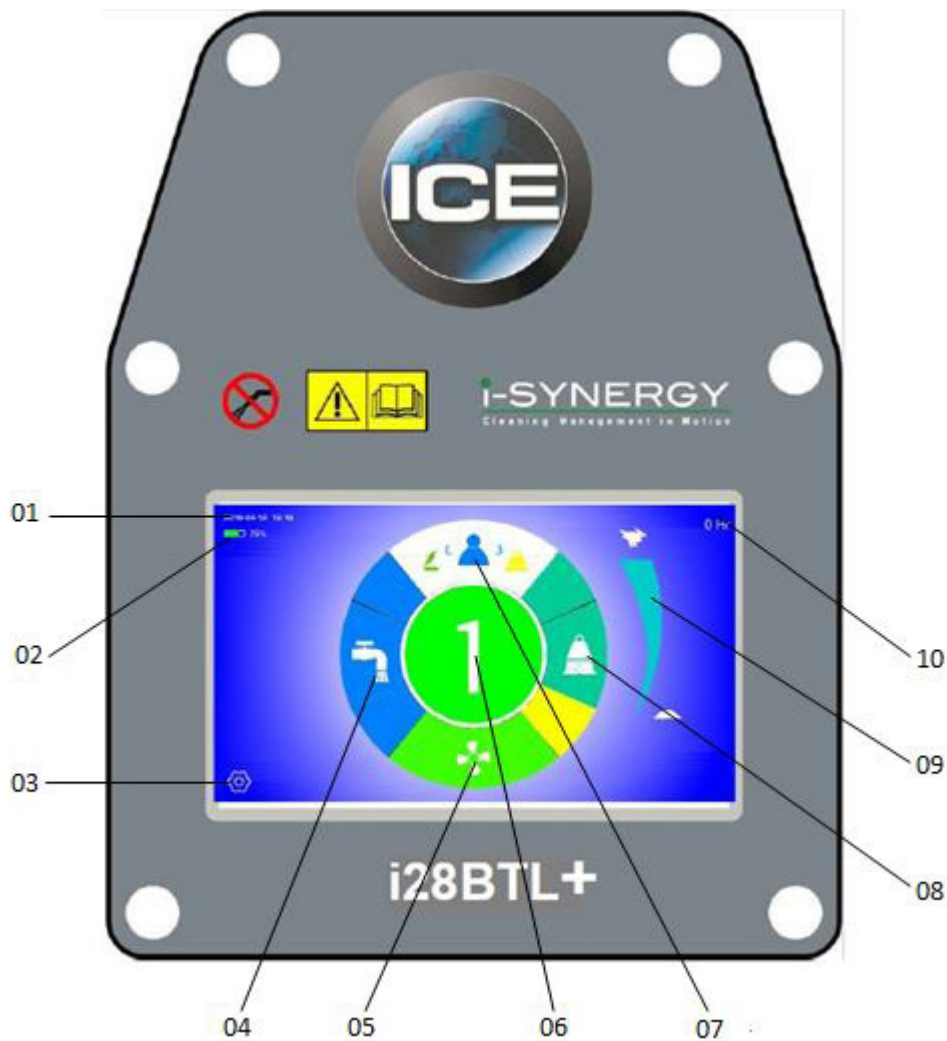

- 01 Date&Time
- 02 Battery meter
- 03 Setting button
- 04 Solution flow adjusting button
- 05 Vacuum motor button
- 06 1-step starting button
- 07 Work mode select button
- 08 Scrub head pressure adjusting button
- 09 Speed adjusting button
- 10 Timer

i-synergy™ INTRODUCTION

i-synergy™ collects operational data from cleaning machines and transmit the information to ICE's server. The ICE server generates daily reports and send them to designated end users by email. From these reports, end users will have information about machines' usage and even specific timings.

Besides, i-synergy™ also collects data on lithium-ion battery, vacuum motor, brush deck motor, transaxle, and other electrical components at least once every minute when the machine is in use and even during battery charging.

i-synergy™ will send notifications instantly to the ICE server in case of any malfunction. ICE maintenance personnel will receive a SMS within minutes from the ICE server for immediate servicing.

MACHINE SET UP & INSTALLATION

UNCRATING MACHINE

Be sure and check packing carton for any damage. Immediately report any damage to carrier. Check the contents of package to ensure that the following items are included:

- Machine
- Lithium-ion Batteries
- Squeegee assembly
- 2-Pad Drivers
- 2-Brushes

INSTALLING BATTERIES

The machine uses the Lithium-ion batteries, the batteries are already in the machine upon delivery; However you will need to connect the Lithium ion batteries to the machine.



WARNING: Fire or Explosion Hazard. Keep sparks and open flames away! Keep battery compartment open when charging.

1. Turn off the machine.
2. Open recovery tank to gain access to battery compartment.
3. Carefully place the Lithium-ion batteries into the compartment. Place the battery brace at the rear of the batteries.

DO NOT DROP BATTERIES INTO COMPARTMENT!

4. Plug the batteries connector to the machine adaptor, connect machine i-synergy™ COM port with the batteries.

MACHINE SET UP

PRE-OPERATION CHECKS

1. Sweep or dust mop the surface to be cleaned.
2. Check battery meter to make sure batteries are fully charged. (See BATTERY CHARGING)
3. Check that squeegee is properly installed.
4. Check that brushes / pads is properly installed.

INSTALLING BRUSHES OR PADS

1. Turn off the 1-Step scrub head up/down button (Panel components, item #12) and Raise the Scrub head off the floor, then stop machine on the level surface, ensure the machine is turned off.
2. If using the Pad Driver, first attach the appropriate pad to the pad driver surface.
3. Align the pad driver or brush under the motor hub and push it upward to engage.



4. To remove the pad driver or brush, raise the scrub head and push the pad release plunger (Machine components, item #30) downward.

MOUNTING THE SQUEEGEE ASSEMBLY

1. Lift the squeegee lift lever (Machine components, item #8) to the upward position.
2. Mount the squeegee assembly to the squeegee pivot bracket. make sure the knobs are completely seated into the slots before securing knobs.
3. Connect the vacuum hose to the squeegee assembly. Loop the hose by using the hose clip provided.
4. Check the squeegee blades for proper adjustment.

OPERATOR MANUAL

FILLING THE SOLUTION TANK

The machine is equipped with a hose fill-port (Machine components, item #7) at the rear of the machine, and a bucket fill-port (Machine components, item #26) located under the recovery tank. Before accessing the bucket fill-port make sure that the recovery tank is empty.

Fill the solution tank to the "100L" level on the solution tank sight gauge. When using the bucket fill-port, stop filling when the level reaches the bottom edge of the fill-port.

Conventional scrubbing - Fill solution tank with water (not to exceed 60°C/140°F. Pour a recommended cleaning detergent into the solution tank according to mixing instructions on the container)

NOTE: When filling the solution tank with a bucket, make sure that the bucket is clean. Do not use the same bucket for filling and draining the machine.



WARNING: Do not put any flammable materials into solution tank. this can cause an explosion or a fire. Only use recommended cleaning chemicals. Contact your janitorial supply distributor for recommendations on proper chemicals.

MACHINE OPERATION



WARNING: Do not operate machine unless you have read and understand this manual.

1. Swiping the ID card (Machine components, item #18) to turn on the machine.
2. Check the LED display screen (Panel components, item #4), if there are fault codes (Panel components, item #18) and the Fault indicator (Panel components, item #1) in blink, please DO NOT operate the machine unless the faults have been eliminated (please see *FAULT CODES AND ELIMINATE* section).
3. Turn on the 1-Step scrub head up/down button, the scrub head will be lowered down automatically.
4. Lower squeegee assembly to the floor by lowering the Squeegee lift lever.
5. Check the solution flow indicator (Panel components, item #9), press the Solution flow adjusting button (Panel components, item #10) to get a desired solution flow.

NOTE: Solution will not begin to flow until the control handle bail is pulled.

6. Turn on the Vacuum motor switch (Panel components, item #8).
7. Pull the Control handle bail (machine components, item #17) backwards to start scrubbing. The machine will automatically propel forward. To reverse the machine, simply push the control handle bail forward.
NOTE: Raise squeegee when reversing machine.
8. The scrubbing speed can be adjusted, press the Speed increase/ decrease button (Panel components, item #14, #16) to a desired speed.
NOTE: 45-60 meters (150-200 ft) per minute is the recommended scrubbing speed.
9. The brush pressure can be adjusted, press the Brush pressure increase/ decrease button (Panel components, item #3, #6) to get a desired brush pressure.
10. To stop scrubbing, release the control handle bail, turn off the 1-Step scrub head up/down button to raise the scrub head assembly, raise the squeegee assembly.

WHILE OPERATING MACHINE



WARNING: Fire Or Explosion Hazard. Do Not Pick Up Flammable Materials Or Reactive Metals.

1. Go slow on inclines and slippery surfaces. Do not operate the machine on inclines that exceed 5% (3°).
2. Do not keep the machine in the same position with pad / brush spinning, keep the machine moving to prevent damage to floor finish.
3. If the squeegee assembly leaves streaks on the floor, raise the squeegee off the floor and wipe the blades down with a damp cloth. Pre-sweep the area to prevent leaving streaks on the floor.
4. Pour a recommended defoamer into the recovery tank if excessive foam appears.



WARNING: Do not allow foam to enter the float shut-off screen, vacuum motor damage will result. Foam will not activate the float shut-off screen.

5. Occasionally check the battery meter (Panel components, item #2). when the battery is very low, stop scrubbing and recharge the batteries.



WARNING: When battery meter is in the red, do not continue to operate the machine. Battery damage may result.

- When the solution tank runs empty, press the 1-Step switch raise the brush head. Keep the squeegee down and continue to vacuum until all the dirty water is picked up.

NOTE: *Brush motors will not work when the scrub head assembly raised.*

NOTE: See **TANK DRAINING** section to learn how to drain recovery and solution tanks.

CIRCUIT BREAKER / FUSES

The machine is equipped with 2 resettable circuit breakers(machine components, item #5, item# 6) to protect the main controller from damage. If the circuit breakers should trip, it can't be reset immediately. You must first determine what caused the breaker to trip, and allow the motor to cool down and then you can manually reset the circuit breakers.

The machine is also equipped with a 150A fuse to protect the Lithium-ion batteries from damage. When replacing a fuse never substitute a higher Amps rated fuse than specified.

HOURLY METER

The hour meter (Panel machine components, item #17) records the number of total hours the brush motor has been powered on. Use the hour meter to determine when to perform recommended maintenance procedures and to record service history.

EMERGENCY STOP BUTTON/ BRAKE

The machine is equipped with an Electromagnetic Brake Mechanism on the Transaxle. When in case of Emergency, release the Control Handle bail or strike the Emergency stop button (Machine components, item #4), the machine will be braked and then stop. Reset the emergency stop button, turn on the machine, and then pull the control handle bail, the machine will be restart.

NOTE: *The machine can not be moved unless the Main Power and the Control Handle bail be turned on.*



WARNING: Do Not Change the Default Settings of the Electromagnetic Brake Mechanism unless Authorized, otherwise it may cause Machine Damage or Personal Injury. Contact the Authorized Service center for machine repairs.

TANK DRAINING

- Turn the machine off.
- With the squeegee and scrub head in their "up" position, transport machine to approved area for draining tank(s).

DRAINING THE RECOVERY TANK

Any time scrubbing is completed, or when refilling solution tank, the recovery tank should be drained and cleaned.

WARNING: If the recovery tank is not drained when the solution tank has been refilled, foam or water may enter the float shut-off screen and cause damage to the vacuum motor.

- While holding the drain hose (Machine components, item #3) upward, remove the cap and lower hose to drain.
- Open the recovery tank cover and rinse out the tank. Use a rag to remove any excess dirt.
- Clean the float shut-off screen and debris tray located in the recovery tank .

DRAINING THE SOLUTION TANK

Any time scrubbing operation is completed, the solution tank should be drained and cleaned.

- Pull the solution tank level hose(Machine components, item #12) off the hose fitting, this will allow the solution to flow freely into a bucket or floor drain.
- Remove the cover of the filter assembly (Machine components, item #10) to drain the solution tank, check the filter screen and clean up it if necessary.
- Rinse the solution tank with clean water after every use. This will help prevent chemical buildup and clogging of the solution lines.
- After rinsing out the tank, securely reconnect the tank level hose to the hose fitting, replace the filter assembly cover and be sure the filter screen and the "O" ring is in the correct position.

BATTERY CHARGING



WARNING: Fire Or Explosion Hazard.

Keep Sparks and Open Flame Away. Keep Battery Compartment Propped Open When Charging.

Only use ICE supplied or approved batteries charger, use unapproved charger may cause damage to the batteries and machine.

Batteries chargers specifications:

- **Applicable to charging Lithium-ion batteries**
- **Automatic shut off circuit**
- **Output current of 30 Amps**
- **Output voltage of 24 volts**

1. Place machine in a well ventilated area.
2. Turn the machine off.
3. Connect the charger's AC power supply cord to a properly grounded receptable.
4. Prop up the recovery tank by the support stand (Machine components, item #20) for ventilation when charging.
5. The charger will automatically begin to charge and will automatically shut off once the batteries are fully charged.
6. Upon completion of charging, disconnect the AC power supply cord.

PREVENTATIVE MAINTENANCE



WARNING: Before performing any maintenance on the machine, be sure that the power is turned off, or the batteries are disconnected!



WARNING: Repairs are to be completed by Authorized service centers only. Any repairs completed by unauthorized persons will void the warrenty.

DAILY MAINTENANCE

1. Remove pad driver/ brush and clean with approved cleaner.
2. Drain recovery and solution tanks completely and rinse out with clean water. Visually check the recovery tank for debris and clean out as necessary.

3. Raise the squeegee assembly off floor and wipe it down with a damp towel. Be sure to store the squeegee in the up position.
4. Remove the float shut-off assembly and rinse it out with clean water.
5. Clean machine with an approved cleaner and a damp towel.
6. Recharge the batteries.
7. Check the condition of the squeegee blade wiping edge, rotate blade if worn.

MONTHLY MAINTENANCE

1. Clean the battery tops to prevent corrosion.
 2. Check for loose battery cable connections.
 3. Inspect and clean the recovery tank cover seal. Replce it if damaged.
 4. Lubricate all grease points and pivot points with silicon spray and approved grease.
 5. Check the machine for loose nuts and bolts.
- Check the machine for leaks.

MACHINE STORAGE

1. Always store the machine indoors.
2. Always store the machine in a dry area.
3. Always store the machine in its upright position.
4. Always store the machine with the pad driver/ brush raised off the floor.
5. Always store the machine with the squeegee assembly raised off the floor.
6. If storing in an area which may reach freezing temperatures, be sure to drain all fluids from the machine prior to storage. Any damage caused by freezing temperatures will not be covered by the warranty.
7. Drain the recovery tank.
8. Drain the solution tank of all fluid.

CYLINDRICAL BRUSH MODEL

INSTALL BRUSH

1. Raise scrub head off the floor and turn off the power.(remove key)
2. Remove brush door from scrub head by loosening the knob.
3. Attach brush door to the brush end that has the double row of bristles to install brush.
4. Check the brushes to ensure they are properly adjusted.

INSPECT THE BRUSH PATTERN

After installing a new set of cylindrical brushes check the brush pattern to ensure proper brush adjustment.

1. Measure the distance from the front edge of the scrub head to the floor and from the back edge of the scrub head to the floor. The measurements should be the same.
2. To level the scrub head, loosen the lock nut and turn the leveling screw clockwise to lower the rear of the scrub head or counter--clockwise to lower the front.

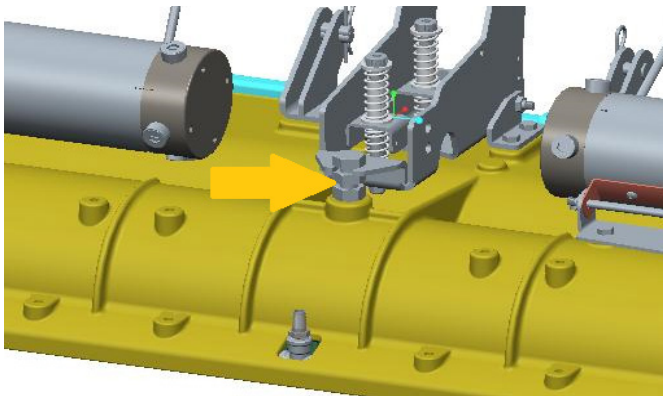

3. Position the machine on a dry dusty floor or apply a powdered substance, such as chalk.
4. Adjust the speed control knob to "zero" ()
5. Shut off the solution flow.
6. Pull the control handle bail to create a brush pattern on the floor.
7. Raise the scrub head and pull the machine away.
8. Observe the brush pattern on floor. If the brush pattern is uneven or tapered, adjustment is required.

Correct Brush Pattern



TO ADJUST A TAPERED BRUSH PATTERN

1. Remove the brush door from the brush.

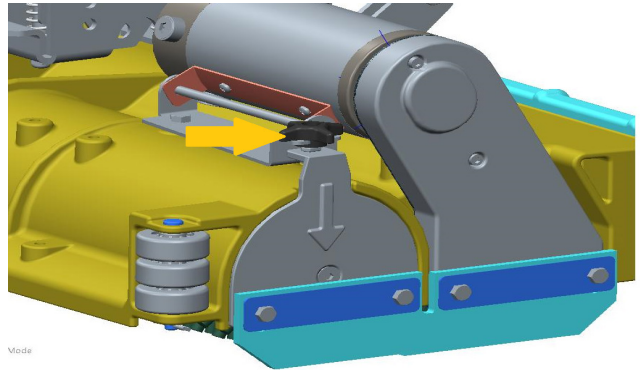

2. Hold the brush plug shaft with a wrench and loosen the 6mm hex screw.

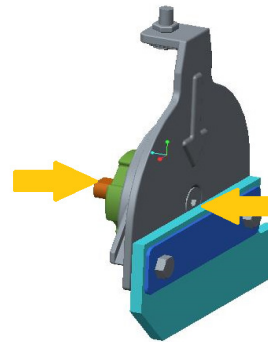

3. To lower the brush end, turn the shaft clockwise for the front brush and counter--clockwise for the rear brush. Retighten hex screw.
4. Recheck brush pattern.
NOTE: Replace brushes when worn to 5/8" (15mm).

Cylindrical Assembly Instructions

Lower scrub head to the ground, then turn off the power (remove key).

STEP#1: Remove Front Cover

1. Remove knob(2) from solution tank.
2. Disconnect cable(1) of the led light.
3. Remove front cover from solution tank.

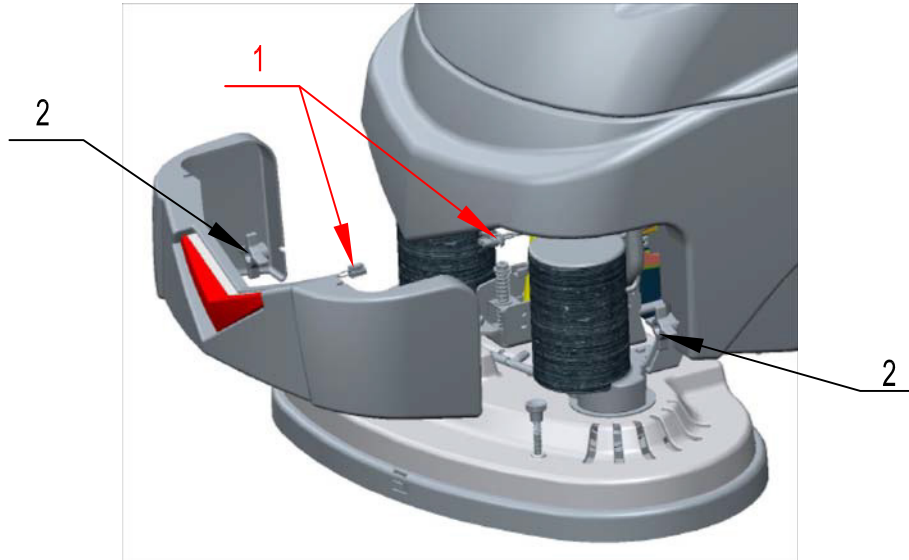

STEP#2: Remove Disc Scrub Head Assembly

1. Remove cotter pin and pins(5) from scrub head lift bracket, then remove cotter pin and pin(3) from spring bracket.
2. Remove lock nut and hex bolt(6) from roller guide(1).
3. Disconnect motor power cords(2).
4. Loosen clamp on the solenoid valve and remove tubing(4).
5. Remove scrub head assembly.

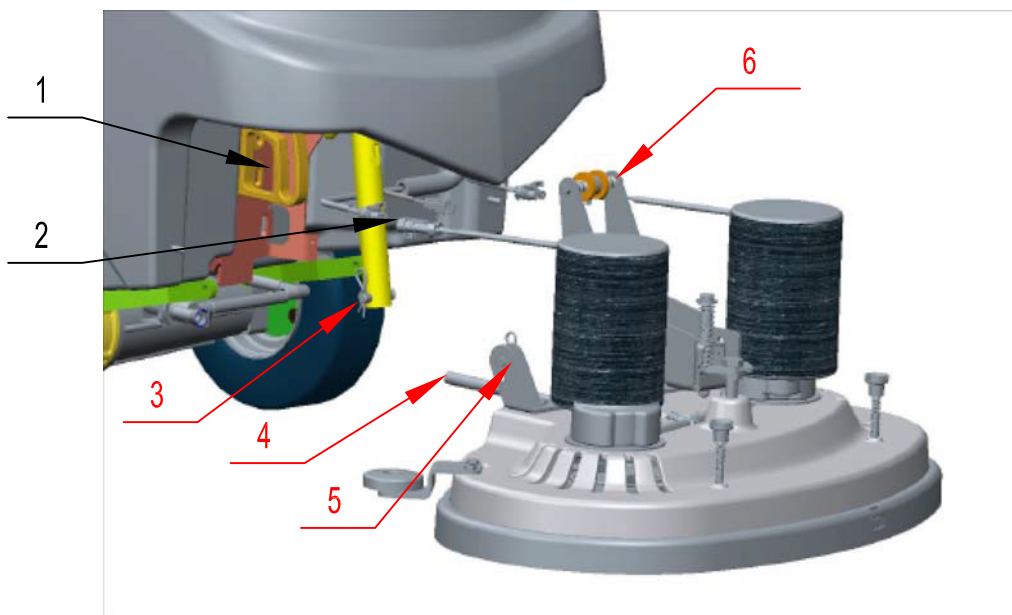

STEP#3: Assembly Cylindrical Scrub Head Group

1. Adjust initial position of sleeve nut(10) on the actuator(1) to right place(L) by rotating manually.
2. Place cylindrical scrub head under solution tank.
3. Connect tubing(3) and fasten clamp.
4. Insert pins into cylindrical scrub head lift bracket(4) through arm(9) installing on the frame, and place cotter pin into holes on the pin.
5. Insert pin into spring bracket(5) through sleeve nut installing on the actuator, and place cotter pin into holes on the pin(6).
6. Insert hex bolt into roller guide(8) through lifting bracket and fasten lock nut(2).
7. Connect motor power cords(7).

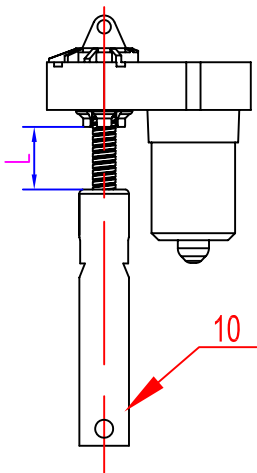

L=35±5MM

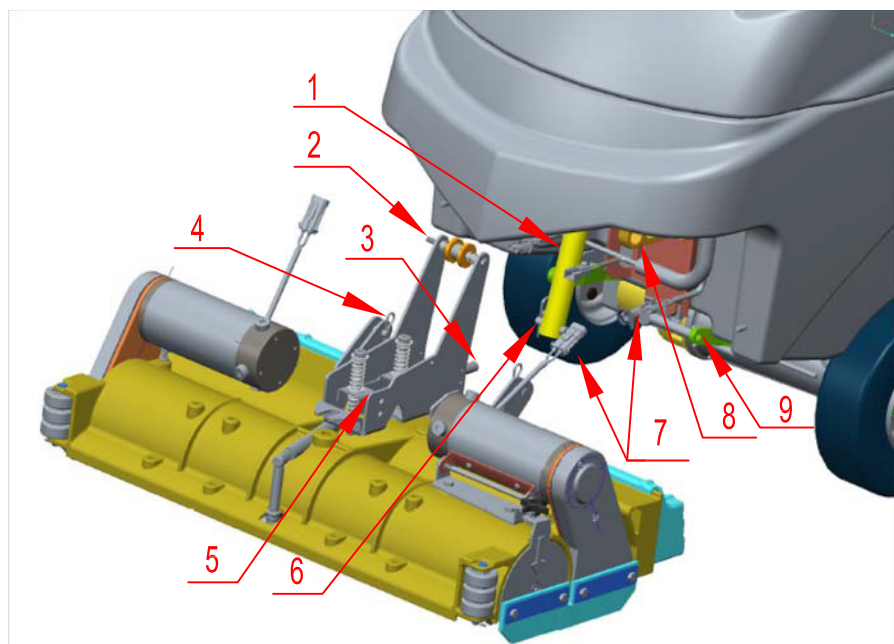

STEP#4: Assembly Front Cover

1. Connect cable of the led light(3).
2. Install front cover through stud fixing(1) on solution tank.
3. Fasten the knobs(2).

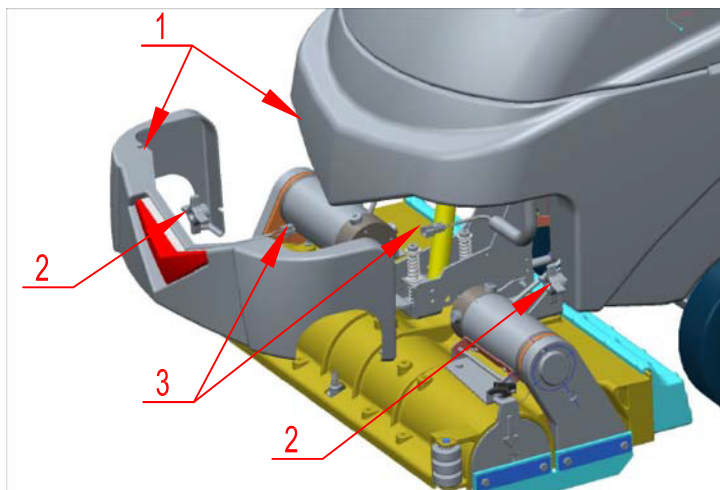

FAULT CODE & SOLUTION

The machine is equipped with a LED display screen (Panel components, item # 4), the LED screen will display the operating hours (Panel components, item # 17) and the battery level status (see Panel components, item # 2).

When the machine detects a fault, there will be a Fault code (Panel components, item #18) & Fault message (Panel components, item #11) display on the LED screen, and the Fault indicator (Panel components, item #1) will flash continuously, accompany an audible alarm Occasionally.

Once fault occurring, please DO NOT continue operate the machine unless the fault are eliminated. Turn off the machine, then to solve the fault, the fault code & message will be eliminated when machine restart.

If the fault is occurred frequently, or the fault can't be eliminated, please contact ICE service center.

Please refer to the below table to determine the fault cause and the solution.

FAULT CODE	FAULT MESSAGE	FAULT CAUSE	SOLUTION
F03	Bru Actt O.L. RESTART!	Scrub head lifting actuator is overload	Turn off the machine,after a moment, RE-START machine.
F04	Vac Mtr O.L. RE-START!	Vacuum motor overload	
F05	Left Bru Mtr O.L. RE-START!	Left brush motor is overload	
F06	Right Bru Mtr O.L. RE-START!	Right brush motor is overload	
F07	Propel Mtr O.L. RE-START!	Propel motor overload	
F08	RecTank Full	Recovery tank is full	Drain the Recovery tank
F10	Batt Low Charge Batt	Battery is low	Charge the battery
F11	Batt Empty Charge Batt NOW	Battery is empty	Charge the battery NOW
F12	Brake Wiring Error	Bad Brake wiring	Check the brake wiring
F14	Replace Brake Assy	Bad Brake assembly	Replace the brake assembly
F16	Control Unit Overheat! Wait	Control Unit Overheat	Turn off the machine,after a moment, RE-START machine
F17	Replace Control Unit	Control Unit Fault	Replace the control unit
F20	Check Left Brush motor	Bad left brush motor	Check left brush motor/ wiring
F21	Check Vac Mtr	Bad Vacuum motor or wiring	Check the vacuum motor / Wiring
F22	Check Soln Solenoid	Solution solenoid wiring fault	Check the wiring & Contactors
F23	Replace Soln solenoid	Bad Solution solenoid	Replace the solution solenoid
F24	Check Propel Motor	Bad propel motor	Check the propel motor / Wiring
F25	Check Right Brush motor	Bad right brush motor	Check right brush motor/ wiring
F40	Check Proximity Sw	Proximity switch fault	Check the Proximity switch
F41	Release Handle	Operation mistake	Release the control handle bail
F42	Replace Control Unit	Bad Control Unit	Replace the control unit
F43	Turn Dead Sw Off RE-START!	Emergency stop button activated	Release emergency stop button and restart machine
F44	Replace Control Unit	Bad Control Unit	Contact service center, Replace the Control Unit
F45	Return Control Unit		
F46	Return Control Unit		
F47	Return Control Unit		
F48	Return Control Unit		

BASIC TROUBLESHOOTING

PROBLEM	CAUSE	SOLUTION
Machine will not operate	Control handle bail not pulled	Pull control handle bail
	Batteries need to be charged	Charge batteries
	Bad lithium-ion batteries	Replace batteries
	Emergency stop button activated	Reset Emergency stop button
	Main PCB fuse blown	Contact ICE service center
	Faulty i-synergy™ module	Contact ICE service center
Brush motor will not operate	1-STEP scrub head up/down switch is off	Turn on the 1-STEP switch
	Battery meter lockout activated	Recharge batteries
	Faulty control handle bail switch	Contact ICE service center
	Faulty brush motor or wiring	Contact ICE service center
	Worn Motor carbon brushes	Contact ICE service center
Machine does not propel	the Control handle bail not pulled	Pull the control handle bail
	Faulty transaxle motor or wiring	Contact ICE service center
	Worn Motor carbon brushes	Contact ICE service center
Vacuum motor will not operate	Faulty vacuum motor or wiring	Contact ICE service center
	Worn Motor carbon brushes	Contact ICE service center
Little or no solution flow	Ball valve set too low or shut off	Turn on the ball valve
	Solution flow control knob set too low or shut off	Adjust solution control flow knob
	Clogged solution tank filter or solution hose	Clean solution tank filter or flush out solution hose
	Clogged solution Solenoid valve	Remove valve and clean
Poor water pick up	Recovery tank is full	Drain recovery tank
	Loose drain hose cap	Tighten cap
	Clogged float shut-off screen located in recovery tank	clean screen
	Clogged squeegee assembly	Clean squeegee assembly
	Worn squeegee blades	Replace or rotate squeegee blades
	Incorrect squeegee blade deflection	Adjust squeegee blade height
	Loose vacuum hose connections	Secure hose connections
	Clogged vacuum hose	Remove clogged debris
	Damaged vacuum hose	Replace vacuum hose
	Recovery tank cover not in place	Properly position cover
	Damaged recovery tank cover seal	Replace seal
	Faulty vacuum motor	Contact ICE service center
	Low battery charge	Recharge batteries
Short run time	Low battery charge	Fully recharge batteries
	Defective batteries	Replace batteries
	Batteries need maintenance	See BATTERY MAINTENANCE
	Faulty battery charger	Repair or replace battery charger
	Down pressure lever is set for extra scrub head pressure	Lower down pressure lever

TECHNICAL SPECIFICATIONS

MODEL	i28BTL-CY	i28BTL	i32BTL
DIMENSIONS - L	61.02 in / 1,550 mm		62.21 in / 1,580 mm
DIMENSIONS - W	30.51 in / 775 mm		34.06 in / 865 mm
DIMENSIONS - H	44.49 in / 1,130 mm		44.49 in / 1,130 mm
WEIGHT	352.74 lbs / 160 Kg		374.79 lbs / 170 Kg
WEIGHT WITH BATTERIES	484 lbs / 220 Kg		506.7 lbs / 230 Kg
SOLUTION TANK CAPACITY	26.42 Gal / 100 L		
RECOVERY TANK CAPACITY	31.7 Gal / 120 L		
SQUEEGEE WIDTH	Standard: 40.5 in / 1,030 mm Option: 44.5 in / 1,130 mm		Standard: 46.5 in / 1,185 mm Option: 44.5 in / 1,130 mm
CLEANING PATH WIDTH	28 in / 700 mm		32 in / 800 mm
PRODUCTIVITY RATE	30,667 ft ² / 2,850 m ² h		34,983 ft ² / 3,250 m ² h
DRIVE SYSTEM	Transaxle, 24VDC, 0.27 hp / 200 W		
TRAVEL SPEED, MAXIMUM	Cleaning: 65 m/Min 213.25 ft/min		Transporting: 72 m/Min 236.22 ft/Min
MINIMUM AISLE TURN	63 in / 1600 mm		
PAD/BRUSH PRESSURE	0 ~ 79.37 lbs 0 ~ 36 kg	39.68 lbs / 18 kg 79.37 lbs / 36 kg 119.05 lbs / 54 kg	
SOLUTION FLOW RATE	0 ~ 0.66 Gal / Min 0 ~ 2.5 L/Min		
BRUSH / CYLINDRICAL MOTORS	0.75 hp / 560W × 2, 750 RPM	0.75 hp / 550W × 2, 210 RPM	
BRUSH / CYLINDRICAL DIMENSIONS (x2)	Dia: 150 mm / 6 in Length: 700 mm / 28 in	Diameter: 355.6 mm / 14 in	Diameter: 406.4 mm / 16 in
VACUUM MOTOR	0.8 hp / 600 W		
WATER LIFT - AIR FLOW	65 in / 1650 mm		
BATTERIES	Lithium-ion Batteries, 240 AH		
RUN TIME PER CHARGE	3.5~4 Hours		
VOLTAGE DC	24 V		
DECIBEL RATING AT OPERATOR'S EAR, INDOORS	68 dB(A)		
GRADE LEVEL, MAX	5% (3°)		

RECOVERY TANK GROUP

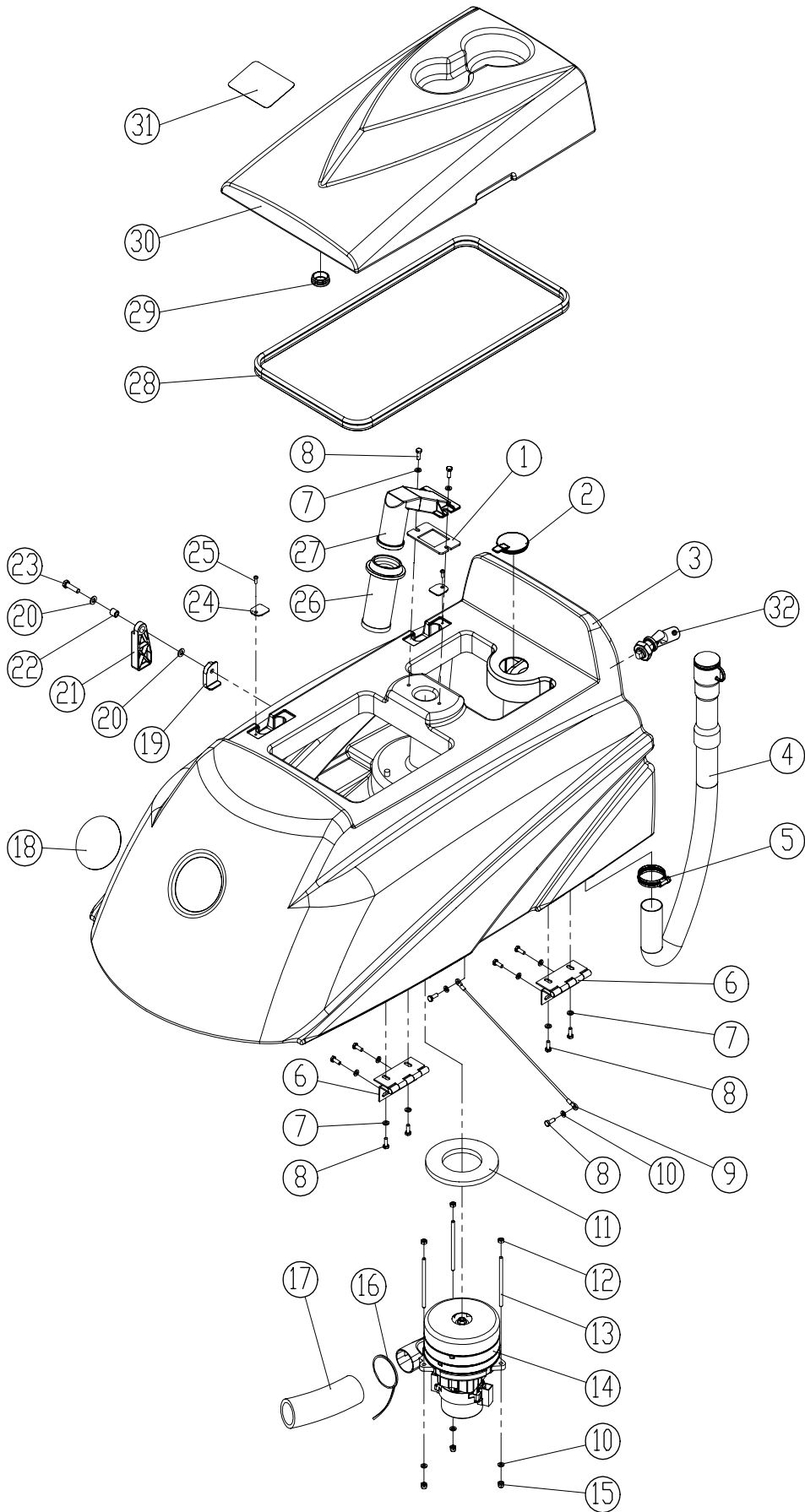

PARTS LIST

RECOVERY TANK GROUP

DIA NO.	PART NUMBER	DESCRIPTION	SERIAL NUMBER	NO REQ'D
1	8111001	GASKET		1
2	8131003	CAP	60304100101~60304100266 60305100101~60305100502	1
	8131004	CAP	60304100267~ 60305100503~	
3	8210102B	RECOVERY TANK GROUP		1
4	8131030	DRAIN HOSE	60304100101~60304100249 60305100101~60305100292	1
	8131031	DRAIN HOSE	60304100250~ 60305100425~	1
5	1962050	CLAMP		1
6	8111300	HINGE ASSEMBLY		2
7	1421618	FLAT WASHER M6×18×1.6		10
8	1021616	HEX BOLT M6 X 16		12
9	8210207	CABLE		1
10	1421612	FLAT WASHER M6×12×1.6		5
11	8112005	GASKET, VACUUM MOTOR		1
12	1121605	HEX NUT M6		3
13	8210209	STUD M6×110		3
14	8210299	VACUUM MOTOR 24VDC, KIT		1
	8112008	CARBON BRUSH, VACUUM MOTOR		2
15	1123608	LOCK NUT M6		3
16	1914300	TIE, NYLON, 5X300		1
17	8132007	MUFFLER, VACUUM MOTOR		1
18	4010316	ICE LOGO		1
19	8111008	BRACKET		1
20	1421816	FLAT WASHER M8×16×1.6		2
21	8111007	RECOVERY TANK SUPPORT		1
22	8115404	SLEEVE, P/M		1
23	1021830	HEX BOLT M8×30		1
24	8111016	PLATE		2
25	1221512	SCREW M5×12		2
26	8111015	FLOAT, SHUT-OFF		1
27	8111014	FLOAT ADAPTER		1
28	8210201	RECOVERY TANK COVER SEAL		1
29	8011005	CAP		1
30	8210103	RECOVERY TANK COVER		1
31	8111022	WARNING LABEL		1
32	8310238A	WATER LEVEL SENSOR GROUP	60304100101~ 60305100101~	1

Note:

No.2、4: Supplier changes, part coding changes.

SOLUTION TANK GROUP

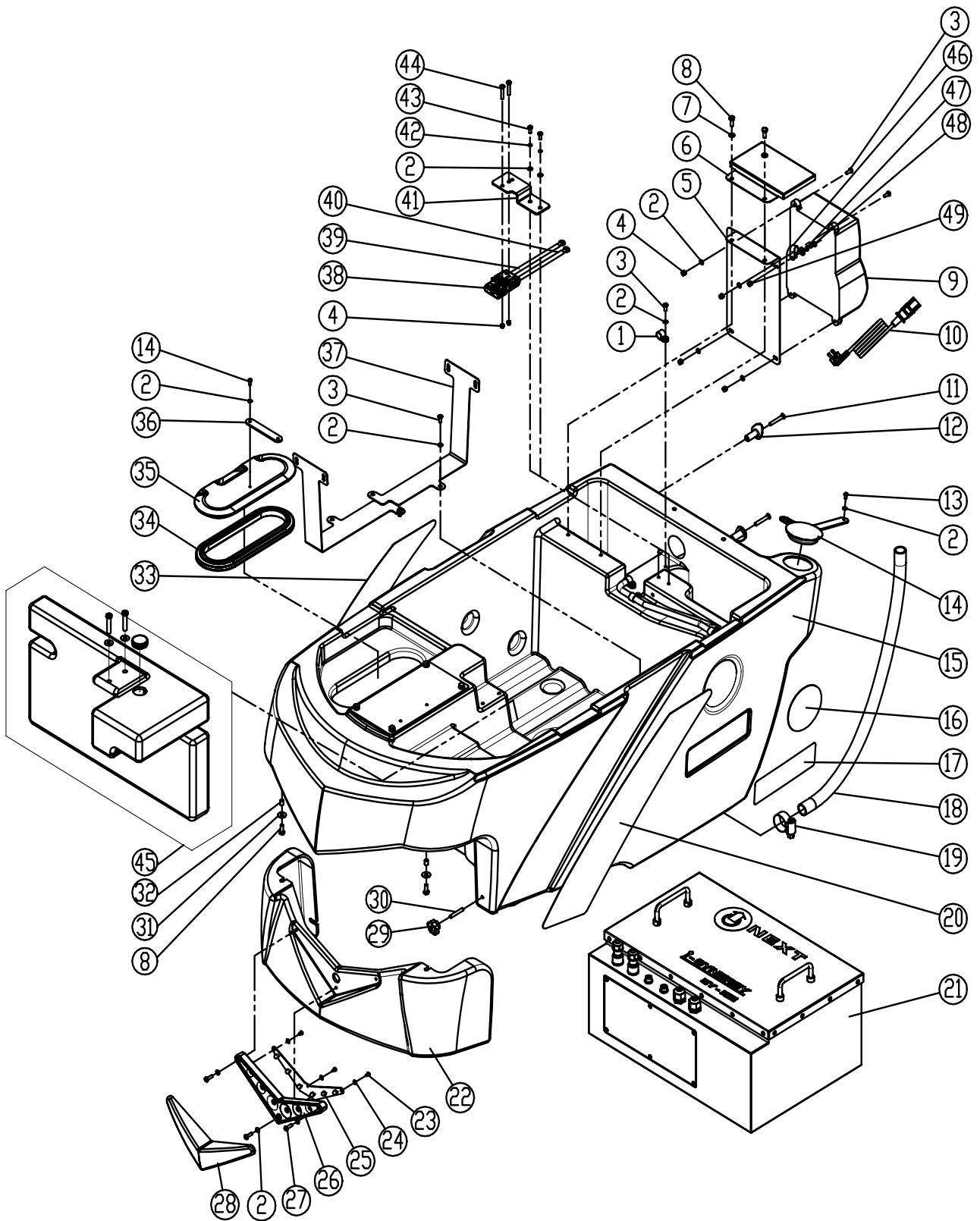

PARTS LIST

SOLUTION TANK GROUP

DIA NO.	PART NUMBER	DESCRIPTION	SERIAL NUMBER	NO REQ'D
1	6210131	NYLON, CLAMP		12
2	1421510	FLAT WASHER M5×10×1		32
3	1221520	SCREW M5×20		24
4	1123507	LOCK NUT M5		6
5	8210127	BRACKET, BATTERY CHARGER MNTG	60304100101~60304100256 60305100101~60305100470	1
	8210119	BRACKET, BATTERY CHARGER MNTG	60304100257~ 60305100471~	1
6	8210117	CAP, CHARGER		1
7	1421612	FLAT WASHER M6×12×1.6		12
8	1021616	HEX BOLT M6 X 16		10
9	8311720	ON BOARD LI-ION BATTERY CHARGER	60304100101~60304100162 60305100101~60305100157	1
	8350509	ON BOARD LI-ION BATTERY CHARGER	60304100163~ 60305100158~	1
10	8312060US	POWER CORD, BATTERY CHARGER, US		1
	8312060EU	POWER CORD, BATTERY CHARGER, EU		1
	8312060JP	POWER CORD, BATTERY CHARGER, JP		1
	8312060	POWER CORD, BATTERY CHARGER, CH		1
	8312060UK	POWER CORD, BATTERY CHARGER, UK		1
11	1222641	SCREW M6 X 40		2
12	8210112	HOOK, CORD		2
13	1321213	SELF-TAPPING SCREW ST4.2X13		2
14	8210113	CAP, SOLUTION FILL		1
15	8210101	SOLUTION TANK		1
16	4010316	ICE LOGO		2
17	8130099	I-SYNERGY LOGO		2
18	8210145	CLEAN TUBING		1
19	1962025	CLAMP 16-25mm		1
20	8210151	LABEL, LEFT SIDE		1
21	N240570	LITHIUM-ION BATTERY, 240AH,3G	60304100101~60304100255 60305100101~60305100476	1
	N241600-G	LITHIUM-ION BATTERY, 240AH,4G	60304100256~ 60305100477~	1

SOLUTION TANK GROUP

DIA NO.	PART NUMBER	DESCRIPTION	SERIAL NUMBER	NO REQ'D
22	8210104	COVER, FRONT		1
23	1321110	SELF-TAPPING SCREW ST3.5 ×10		3
24	1421409	FLAT WASHER M4×9×0.8		5
25	8133610	LED LIGHT KIT		1
26	8133601	LED LIGHT MNTG BASE		1
27	1221520	SCREW M5X20		3
28	8133602	LED LIGHT COVER		1
29	8210531	KNOB, M6		2
30	1535630	SET SCREW M6 ×30		2
31	1421618	PLAIN WASHER 6×18×1.6,SS		4
32	8113112	BUSHING		2
33	8210152	LABEL, RIGHT SIDE		1
34	8113030	SEAL		1
35	8113002	COVER		1
36	8113007	STRAP		1
37	8210168	PLATE		2
38	8210163	CONNECTOR HOUSING		1
39	8210723	BATTERY CONNECT CABLE, RED		1
40	8210724	BATTERY CONNECT CABLE, BLACK		1
41	8210164	BRACKET, CONNECTOR		1
42	1422515	SPRING WASHER,M5		2
43	1021512	HEX HEAD SCREW, M5X12		2
44	1221525	PAN HEAD SCREW, M5X25		2
45	8210630	CLUMP WEIGHT GROUP	60304100222~ 60305100245~	1
46	1885119	NYLON, CLAMP	60304100271~ 60305100503~	1
47	1422411	SPRING WASHER	60304100271~ 60305100503~	1
48	1221412	SCREW M4×20	60304100271~ 60305100503~	1
49	1123406	LOCK NUT M4	60304100271~ 60305100503~	1

Note:

No.5 This charger bracket was changed to U hole from circle hole to adapt flex charger, this bracket can also adapt original charger 8311720.

No.9 The battery charger supplier was changed.

No.21 Use 4G battery N241650 instead of N240650

No.45 New add clump weight group.

No.46~49 Structural optimization of new parts.

CONTROL CONSOLE GROUP

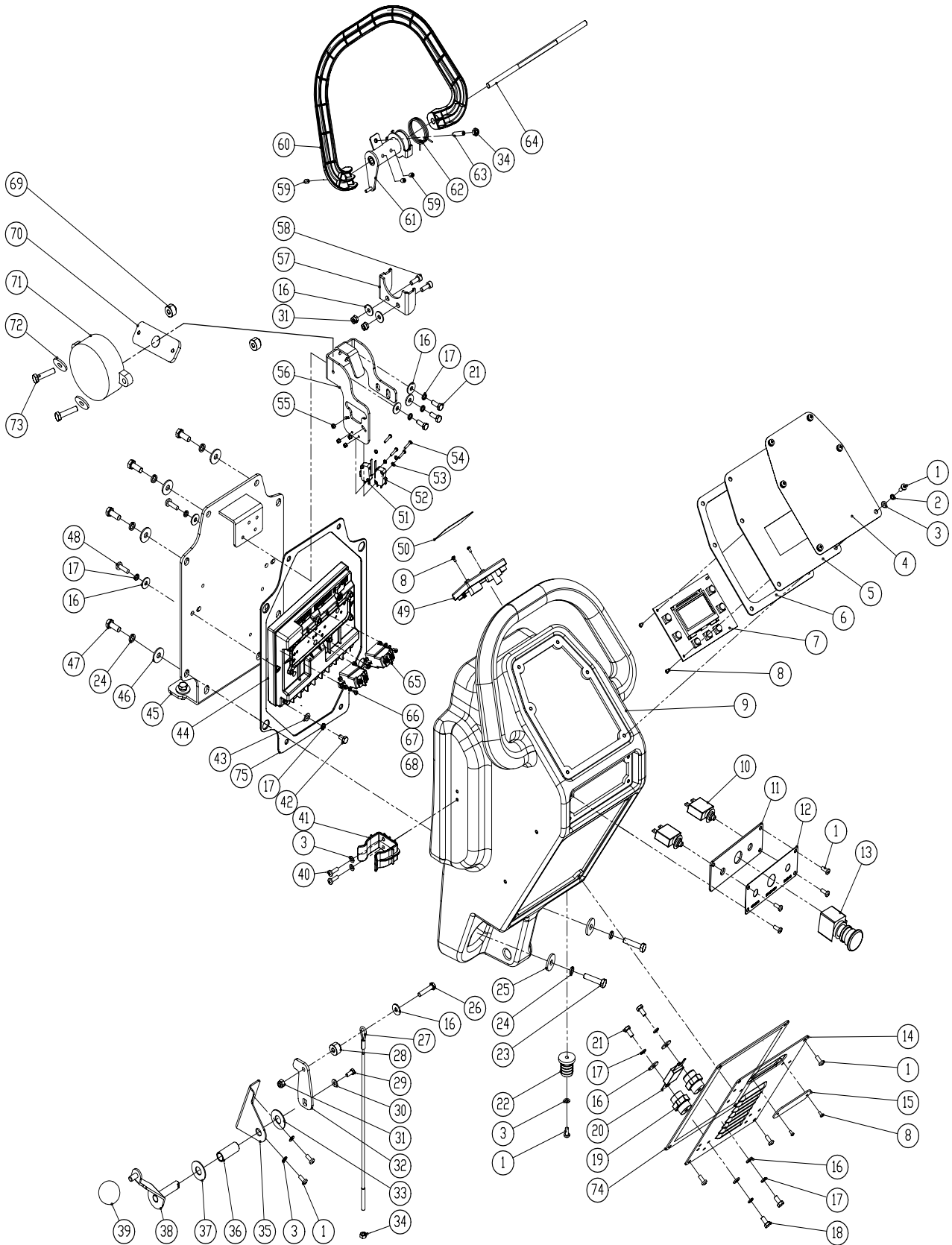

CONTROL CONSOLE GROUP

DIA NO.	PART NUMBER	DESCRIPTION	SERIAL NUMBER	NO REQ'D
1	1221512	SCREW M5×12		17
2	1422513	LOCK WASHER M5		6
3	1421510	FLAT WASHER M5×10×1.0		13
4	8210535	CONTROL PANEL DECAL, i28BTL+		1
	8210536	CONTROL PANEL DECAL, i32BTL+		1
5	8174505	CONTROL PANEL		1
6	8134015	GASKET	60304100101~ 60305100101~	1
7	8134905	5" ANDROID LCD SCREEN		1
8	1221306	SCREW M3×6		6
9	8134005	CONTROL HOUSING		1
10	8310740	CIRCUIT BREAKER, 5A		2
11	8134008	PLATE, EMERGENCY STOP MNTG		1
12	8144029	DECAL, EMERGENCY STOP		1
13	8310707	EMERGENCY STOP BUTTON		1
14	8134060-1	PLATE, ON BOARD BATTERY CHARGER		1
15	8134061	CLEAR COVER		1
16	1421618	PLAIN WASHER M6×φ18×1.6,SS		12
17	1422616	LOCK WASHER, M6		20
18	1021616	HEX BOLT M6 X 10		2
19	8114705	STAND-OFF, M6		2
20	1885289	FUSE,150A		1
21	1021616	HEX BOLT M6 X 16		5
22	8114005	CONNECTOR		1
23	1021840	HEX BOLT M8×40		2
24	1422821	LOCK WASHER M8		12
25	1421828	FLAT WASHER M8×φ28×3		2
26	1021630	HEX HEAD BOLT M6×30,SS		1
27	8210475	CABLE, SQGE LIFT	60304100101~ 60305100101~	1
28	8014101	LIFTING ROPE SPACER		1
29	1021512	HEX HEAD BOLT M5×12,SS		2
30	1421515	FLAT WASHER M5×15×1.0		1
31	1123608	LOCK NUT M6		3
32	8014012	BAFFLE		1

PARTS LIST

CONTROL CONSOLE GROUP

DIA NO.	PART NUMBER	DESCRIPTION	SERIAL NUMBER	NO REQ'D
33	8113111	NYLON FLAT WASHER $\phi 12.9 \times \phi 25.4 \times 0.8$		1
34	1121605	HEX NUT M6		2
35	8134501	BRACKET		1
36	8134508	SLEEVE		1
37	1421132	FLAT WASHER 12×32×1.5		1
38	8014010	SQUEEGEE LIFTING HANDLE		1
39	8113104	BALL KNOB M8		1
40	1221515	PH SCREW M5×15,SS		2
41	6210111	CLAMP, DRAIN HOSE		1
42	1023612	HEX BOLT M6 X 12, COPPER		10
43	1423612	FLAT WASHER M6× $\phi 12 \times 1$, COPPER		10
44	8210550	MAIN CONTROLLER, i32BTL+		1
45	8134070	REAR PLATE, CONTROL CONSOLE		1
46	1421824	FLAT WASHER M8× $\phi 24 \times 2$		10
47	1021820	HEX BOLT M8×20		10
48	1221620	PH SCREW M6×20		2
49	8134775	RFID BOARD		1
50	8134035	LABEL, i-SYNERGY™ CARD SCANNING		1
51	8114712	MICRO SWITCH		1
52	8124743	MICRO SWITCH		1
53	1434300	LOCK WASHER, TOOTH, M3		4
54	1021320	SCREW M3 X 20		4
55	1123305	LOCK NUT M3		4
56	8134022	BRACKET, SWITCH		1
57	8114402	BRACKET, SPRING		1
58	1521616	SCREW M6X16, HEX SCOKET		2
59	1534608	SET SCREW M6 ×8		4
60	8134300	LEVER, BAIL		1
61	8114300	ACTUATOR		1
62	8114306	SPRING		1
63	1535630	SET SCREW M6 ×30		1
64	8114101	SHAFT		1

CONTROL CONSOLE GROUP

DIA NO.	PART NUMBER	DESCRIPTION	SERIAL NUMBER	NO REQ'D
65	8313420	RELAY,24VDC,120A		2
66	1221412	SCREW, HEX HEAD, M4X12		4
67	1411409	WASHER , PLAIN , M4X9X0.8		4
68	1422411	LOCK WASHER M4		4
69	1111302	HEX NUT M3		2
70	8134023	BRACKET,HORN	60304100165~ 60305100158~	1
71	8310708A	HORN, 24VDC		1
72	1421307	FLAT WASHER		2
73	1211320	HEX BOLT		2
74	8134083	SEALING GASKET	60304100222~ 60305100425~	1
75	8134085	BACK SEALING GASKET	60304100261~ 60305100477~	1

Note:

The part NO.66 is new added for easy assembly and service the horn.

The part NO.74、75 are new parts for structural optimization.

FRAME & TRANSAXLE GROUP

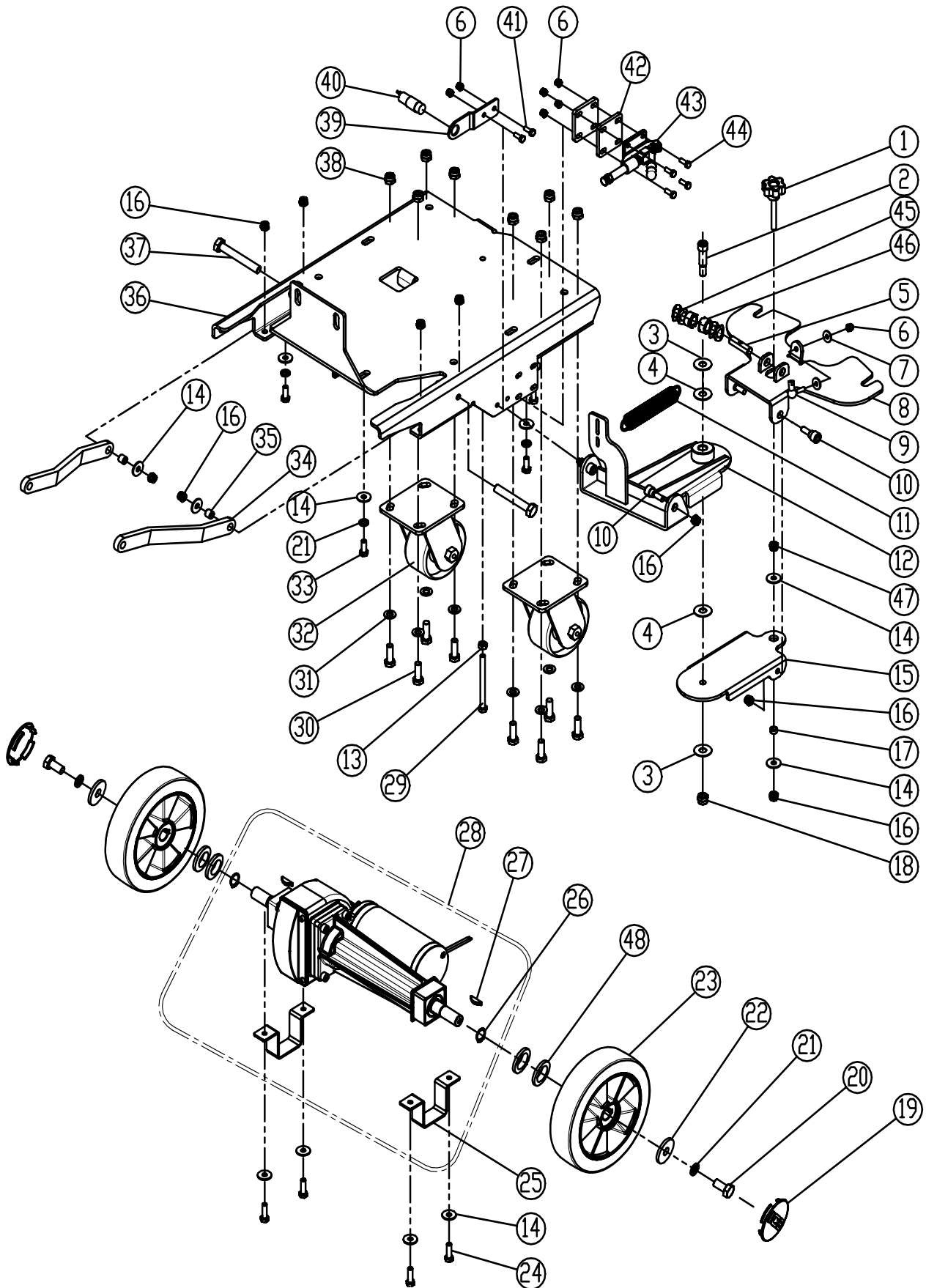

FRAME & TRANSAXLE GROUP

DIA NO.	PART NUMBER	DESCRIPTION	SERIAL NUMBER	NO REQ'D
1	8211507	KNOB M8 ×60		1
2	8211505	SHOULDER SCREW,M12		1
3	1421132	FLAT WASHER 12×32×1.5		2
4	8135001	PLASTIC THRUST WASHER M12× ϕ 30×1.5		2
5	8211506	SHAFT		1
6	1123608	LOCK NUT M6		7
7	1421618	FLAT WASHER M6×18×1.6		2
8	8211503	BRACKET, SQUEEGEE		1
9	8114511	BALL JOINT M6		1
10	8211504	SHOULDER SCREW,M8		4
11	8210508	SPIRNG		1
12	8211501	BRACKET, SQGE LIFT		1
13	1121807	NUT, M8		2
14	1421824	FLAT WASHER M8×24×2		12
15	8211502	BRACKET,SQGE SWING		1
16	1123810	LOCK NUT M8		11
17	8211508	BUSHING		1
18	1123115	LOCK NUT M12		1
19	8115203	COVER, WHEEL		2
20	1021840	HEX BOLT M8 × 40		2
21	1422821	LOCK WASHER M8		7
22	1421828	FLAT WASHER M8×28×2		2
23	8225308	9 INCHE SOLID WHEEL		2
24	1021825	HEX BOLT M8 × 25		4
25	8210123	BRACKET, TRANSAXLE MNTG		2
26	1436019	RETAINING RING 19		2
27	8125403	WOODRUFF KEY		2
28	8210120A	TRANSAXLE, 24VDC		1
29	1022800	HEX BOLT M8 X 100		1
30	1021030	HEX BOLT M10 X 30		8
31	1421020	FLAT WASHER 10×20×2.0		8
32	8210109	4" CASTER		2
33	1021820	HEX BOLT M8×20		5
34	8210115	ARM, SCRUB HEAD LIFTING		2
35	8210116	BUSHING		2
36	8210130	FRAME		1
37	1021855	HEX BOLT M8 × 55		2
38	1123012	LOCK NUT M10		8
39	8210186	BRACKET, PROXIMITY SENSOR		1
40	8134709A	PROXIMITY SENSOR, KIT		1
41	1021616	HEX BOLT M6 × 16		2
42	8210138	SPACER (OPTION)		2
43	8210137	TOGGLE CLAMP, BRAKE (OPTION)		1
44	1021630	HEX BOLT M6 X 30		4
45	1435013	GASKET		4
46	8118085	SHAFT SLEEVE	60304100222~ 60305100425~	2
47	1123809	METAL LOCK NUTS		1
48	8116001	GASKET		4

SCRUB HEAD GROUP

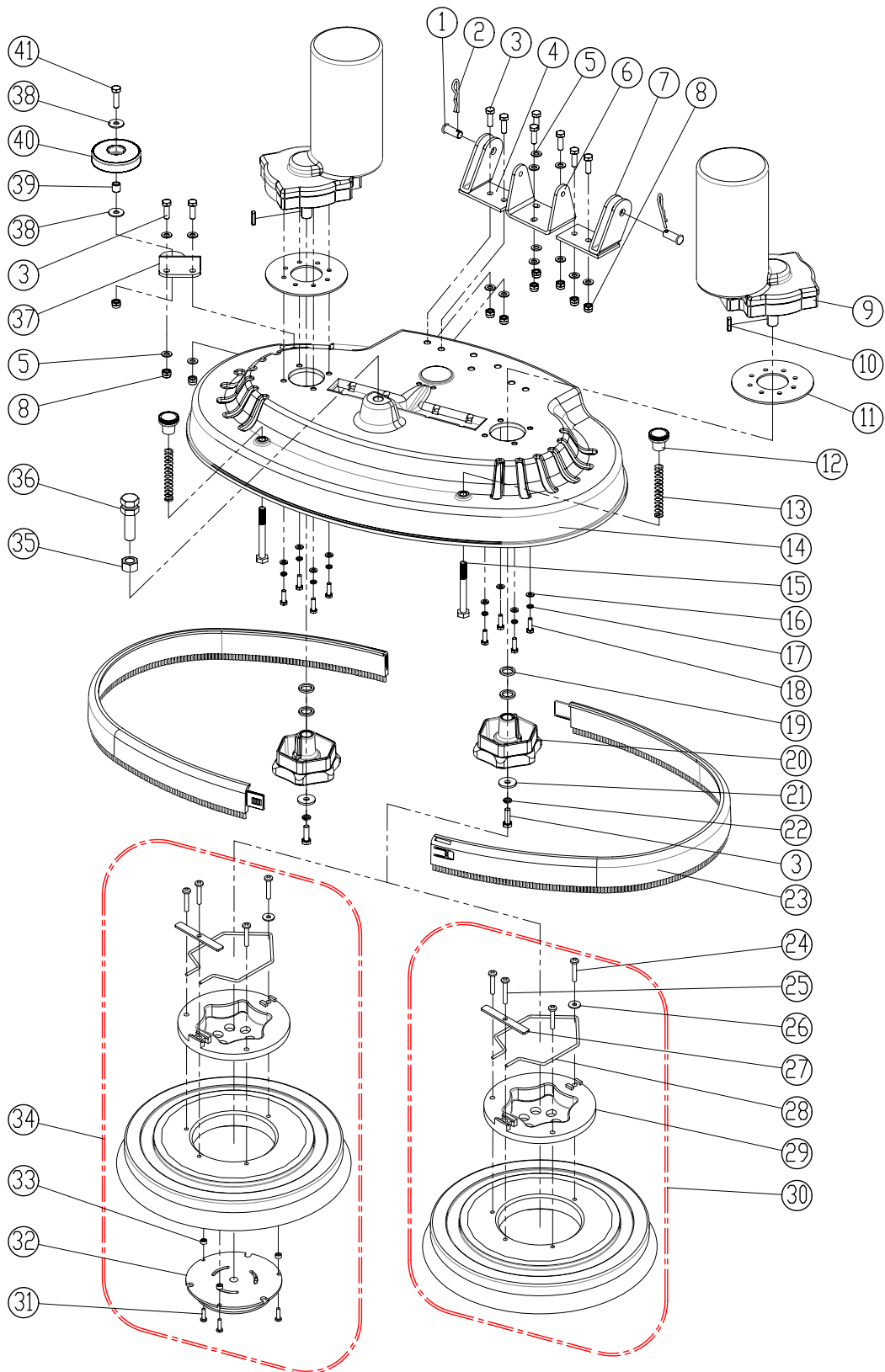

SCRUB HEAD GROUP

DIA NO.	PART NUMBER	DESCRIPTION	SERIAL NUMBER	NO REQ'D
1	8210807	PIN		2
2	8210309	PIN, COTTER		2
3	1021825	HEX BOLT M8 × 25		11
4	8210830	BRACKET, SCRUB HEAD LIFT, RIGHT	60304100101~60304100123 60305100101~60305100129	1
	8210831	BRACKET, SCRUB HEAD LIFT, RIGHT	60304100124~ 60305100147~	1
5	1421816	FLAT WASHER M8×16×1.6		14
6	8210806	BRACKET, ACTUATOR MNTG		1
7	8210820	BRACKET, SCRUB HEAD LIFT, LEFT	60304100101~60304100123 60305100101~60305100129	1
	8210832	BRACKET, SCRUB HEAD LIFT, LEFT	60304100124~ 60305100147~	1
8	1123810	LOCK NUT M8		10
9	8210899	BRUSH MOTOR, 24VDC, 550W, KIT		2
	8210850	CARBON BRUSH		2
10	1655025	KEY, 5X5X25		2
11	8210803	SPACER, RUBBER		2
12	8210808	KNOB, M10		2
13	8210809	SPRING		2
14	8220801	HOUSING, SCRUB HEAD, i28BTL		1
	8210801	HOUSING, SCRUB HEAD, i32BTL		1
15	1022090	HEX BOLT M10 × 90		2
16	1421612	FLAT WASHER M6×12×1.6		8
17	1422616	LOCK WASHER, M6		8
18	1021620	HEX BOLT M6 × 20		8
19	8210804	SPACER		4
20	8210805	HUB, BRUSH DRIVE		2
21	1421828	FLAT WASHER M8×28×3.0		2
22	1422821	LOCK WASHER M8		2
23	8220810	BUMPER, SCRUB HEAD, i28BTL		2
	8218050	BUMPER, SCRUB HEAD, i32BTL		2
24	1221635	SCREW, M6 × 35		12
25	1221640	SCREW, M6 × 40		4
26	1421618	FLAT WASHER M6×18×1.6		4
27	8210861	RETAINER BAR		4
28	8210862	SPRING, G-400S		4
29	9000004	CLUTCH, G-400S		4
30	9050014	BRUSH ASSEMBLY, 14 INCH, i28BTL		2
	9050016	BRUSH ASSEMBLY, 16 INCH, i32BTL		2
31	1321325	SELF-TAPPING SCREW, ST5 X 25		6
32	9000003	CENTER LOCK, #3		2
33	8116040	SPACER, 6.5×14.5×7.0		6
34	9040014	PAD DRIVER, 14INCH, i28BTL		2
	9040016	PAD DRIVER, 14INCH, i32BTL		2
35	1111215	HEX NUT, M16		1
36	8210811	AJUSTMENT STUD, M16		1
37	8210810	BRACKET, ROLLER MNTG		1
38	1421824	FLAT WASHER M8×24×2		2
39	8115404	SLEEVE, P/M		1
40	8116009	PROTECTIVE WHEEL		1
41	1021830	HEX BOLT M8 × 30		1

SCRUB HEAD LIFT GROUP

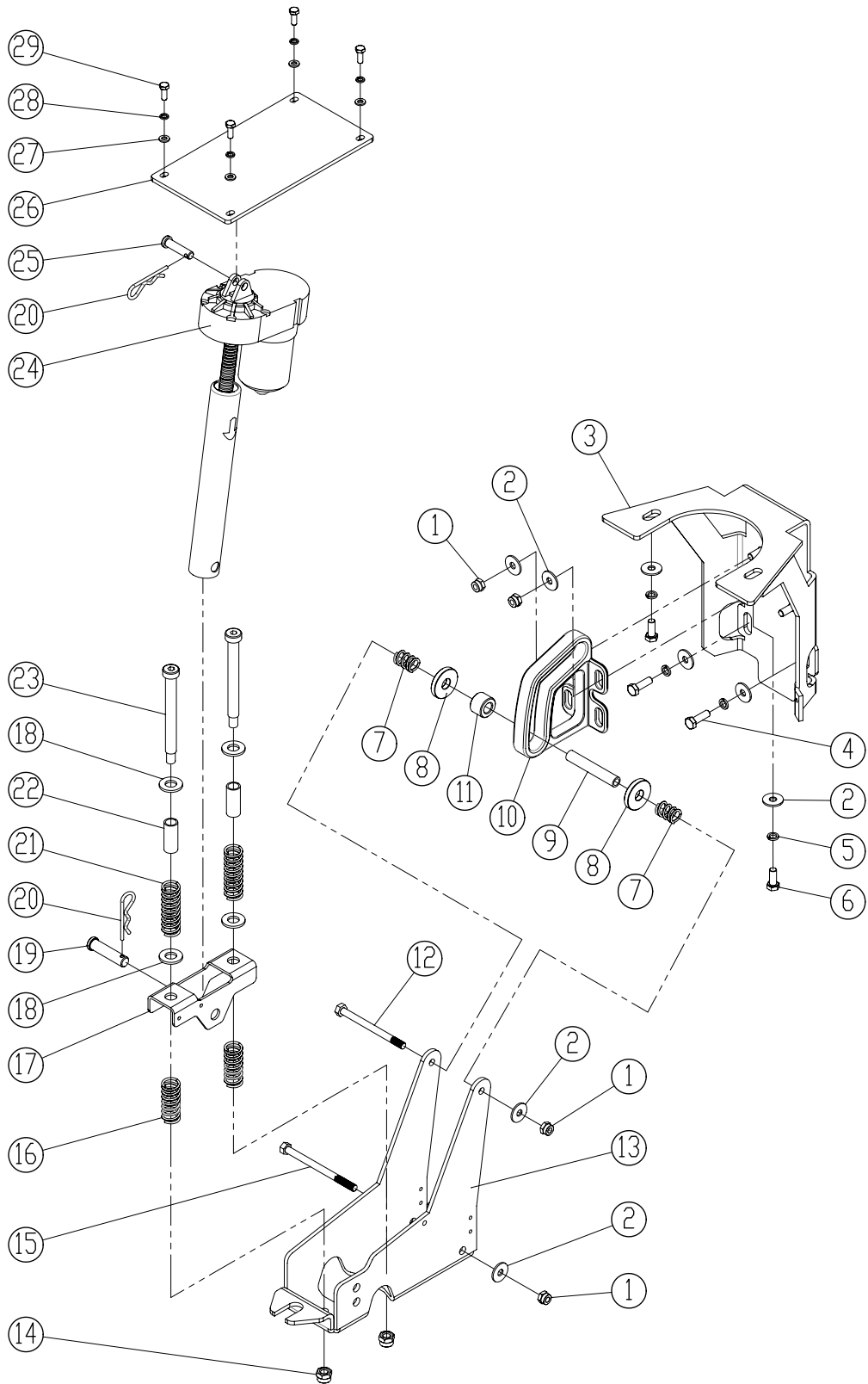

SCRUB HEAD LIFT GROUP

DIA NO.	PART NUMBER	DESCRIPTION	SERIAL NUMBER	NO REQ'D
1	1123810	LOCK NUT M8		6
2	1421824	FLAT WASHER M8×24×2		10
3	8210306	BRACKET, GUIDE MNTG		1
4	1021825	HEX BOLT M8×25		2
5	1422821	LOCK WASHER M8		4
6	1021820	HEX BOLT M8×20		2
7	8210311	SPRING		2
8	8210312	WASHER, PM		2
9	8210314	BUSHING		1
10	8210310	GUIDE, ROLLER		1
11	8210313	ROLLER		1
12	1022800	HEX BOLT M8 X 100		1
13	8210316	BRACKET, SCRUB LIFT		1
14	1123008	LOCK NUT 3/8		2
15	1022811	HEX BOLT M8 X 110		1
16	8210319	SPRING		2
17	8210317	BRACKET, SPRING		1
18	1421132	FLAT WASHER 12×32×1.5		4
19	8210322	PIN		1
20	8210309	PIN, COTTER		2
21	8210318	SPRING		2
22	8210320	SLEEVE		2
23	8210321	BOLT, SHOULDER, 3/8		2
24	8210302	ACTUATOR, 24VDC		1
25	8210301	PIN		1
26	8210303	BRACKET, ACTUATOR MNTG		1
27	1421612	FLAT WASHER M6×12×1.6		4
28	1422616	LOCK WASHER M6		4
29	1021616	HEX BOLT M6 X 16		4

46.5 INCH SQUEEGEE GROUP (STANDARD)

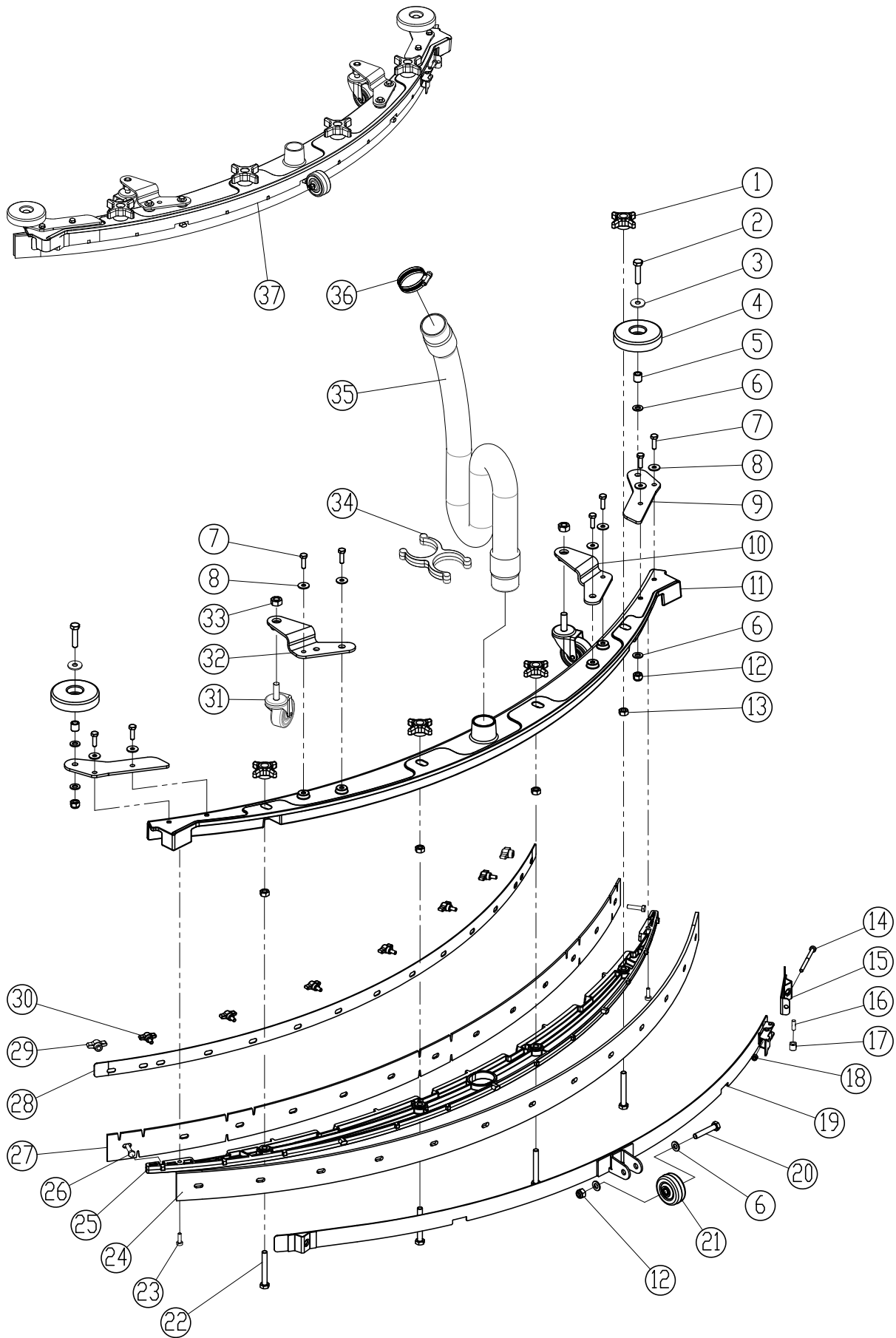

46.5 INCH SQUEEGEE GROUP (STANDARD)

DIA NO.	PART NUMBER	DESCRIPTION	SERIAL NUMBER	NO REQ'D
1	8210518	STAR KNOB M8		4
2	1021835	HEX BOLT M8×35		2
3	1421824	FLAT WASHER M8×24×2.0		2
4	8116009	PROTECTIVE WHEEL		2
5	8115404	BEARING, JOURNAL		2
6	1421816	FLAT WASHER M8×16×1.6		6
7	1021616	HEX BOLT M6×16		8
8	1421618	FLAT WASHER M6×18×1.6		8
9	8210515	BRACKET, ROLLER MNTG		2
10	8118300	LEFT BRACKET		1
11	8210511	SQUEEGEE HOUSING		1
12	1123810	LOCK NUT M8		2
13	1121807	HEX NUT M8		4
14	1221575	SCREW M5×75		1
15	8210525	SHORT CLAMP ASSEMBLY		1
16	8118624	SHAFT		1
17	8118623	SPACER		1
18	1123507	LOCK NUT M5		1
19	8210520	CLAMP ASSEMBLY, SQUEEGEE		1
	8211520	CLAMP ASSEMBLY, SQUEEGEE(OPTION)		1
20	1022845	HEX BOLT M8×45		1
21	8210527	WHEEL, 2 INCH		1
22	1021860	HEX BOLT M8×60		4
23	1221516	SCREW M5×16		2
24	8210514	SQUEEGEE BLADE, REAR, LINATEX		1
	8210517	SQUEEGEE BLADE, REAR, PU (OPTION)		1
25	8210512	RETAINER,SQUEEGEE		1
26	1021625	HEX BOLT M6×25		2
27	8210513	SQUEEGEE BLADE, FRONT, LINATEX		1
	8210516	SQUEEGEE BLADE, FRONT, PU (OPTION)		1
28	8210519	CLAMP, FRONT BLADE		1
29	8210531	KNOB, M6		2
30	8210530	KNOB, M6 × 12		6
31	8118400	CASTER, 2 INCH		2
32	8118200	RIGHT BRACKET		1
33	1121008	HEX NUT M10		2
34	8118109	HOLDER VACUUM HOSE		1
35	8118018	VACUUM HOSE		1
36	1962050	CLAMP		1
37	8210510	SQUEEGEE ASSEMBLY, 46.5 INCH		1

44.5 INCH SQUEEGEE GROUP (OPTION)

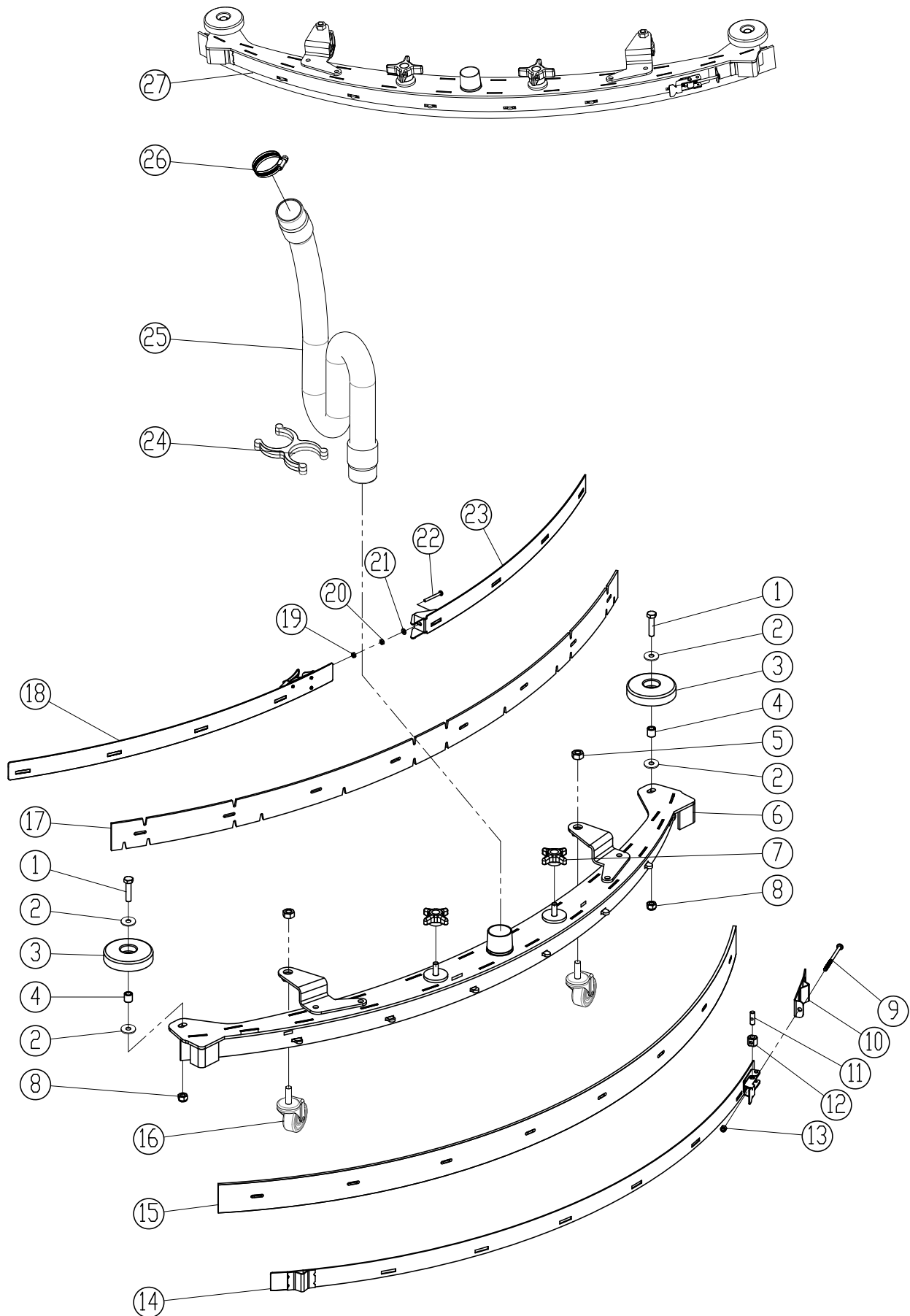

44.5 INCH SQUEEGEE GROUP (OPTION)

DIA NO.	PART NUMBER	DESCRIPTION	SERIAL NUMBER	NO REQ'D
1	1021835	HEX BOLT M8×35		2
2	1421824	FLAT WASHER M8×24×2.0		2
3	8116009	PROTECTIVE WHEEL		2
4	8115404	BEARING, JOURNAL		2
5	1121008	HEX NUT M10		2
6	8220501	SQUEEGEE HOUSING		1
7	8210518	STAR KNOB M8		2
8	1123810	LOCK NUT M8		2
9	1221575	SCREW M5×75		1
10	8210525	SHORT CLAMP ASSEMBLY		1
11	8118624	SHAFT		1
12	8118623	SPACER		1
13	1123507	LOCK NUT M5		1
14	8220521	CLAMP ASSEMBLY, SQUEEGEE		1
15	8220513	SQUEEGEE BLADE, REAR, LINATEX		1
	8220523	SQUEEGEE BLADE, REAR, PU (OPTION)		1
16	8118400	CASTER, 2 INCH		2
17	8220514	SQUEEGEE BLADE, FRONT, LINATEX		1
	8220524	SQUEEGEE BLADE, FRONT, PU (OPTION)		1
18	8220518	FRONT CLAMP, LEFT		1
19	1121403	HEX NUT M4		1
20	1123406	LOCK NUT M4		1
21	1421409	FLAT WASHER M4×9×0.5		1
22	1211435	SCREW M4×35		1
23	8220515	FRONT CLAMP, LEFT		1
24	8118109	HOLDER VACUUM HOSE		1
25	8118018	VACUUM HOSE		1
26	1962050	CLAMP		1
27	8220500	SQUEEGEE ASSEMBLY, 44.5 INCH		1

40.5 INCH SQUEEGEE GROUP (OPTION)

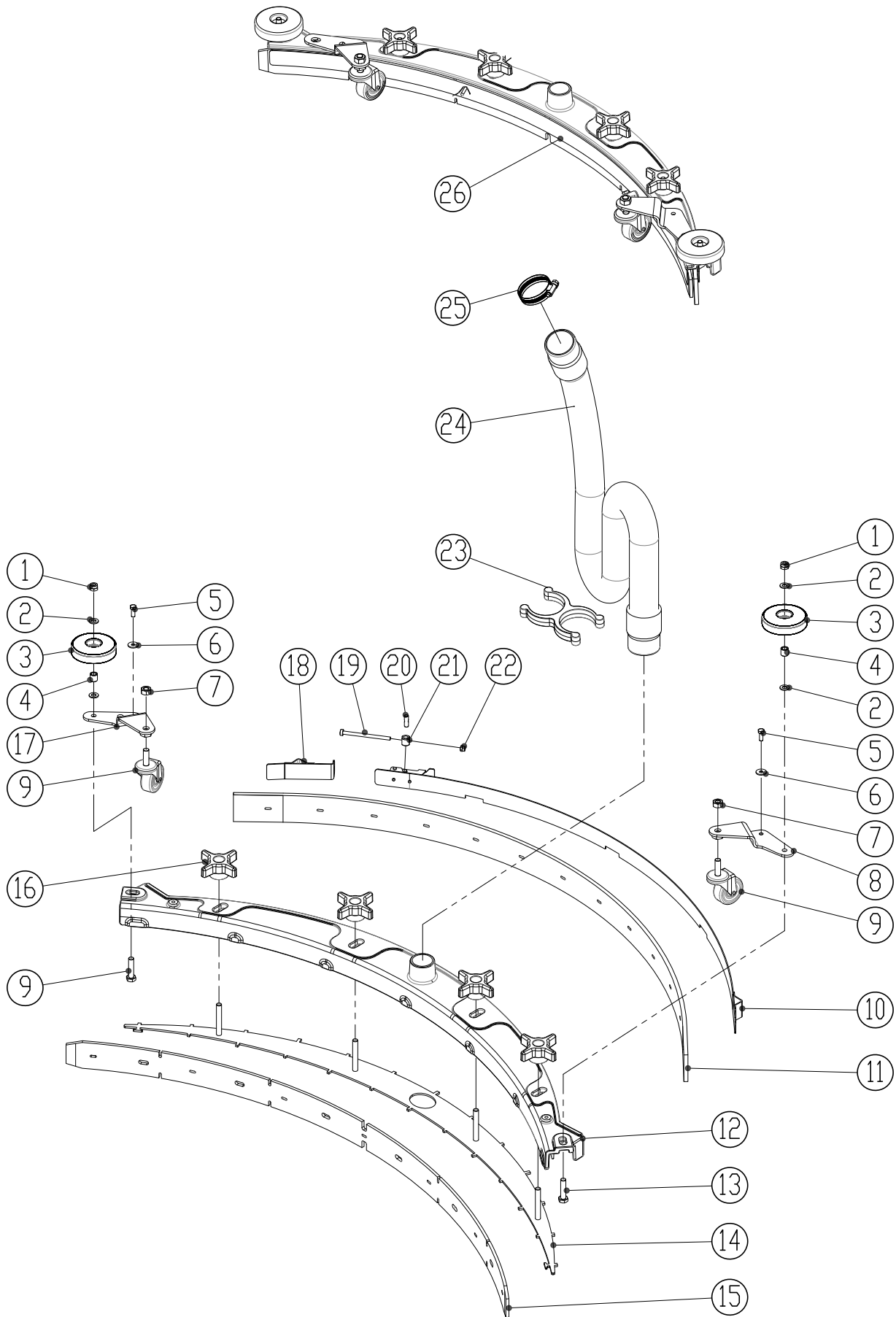

40.5 INCH SQUEEGEE GROUP (OPTION)

DIA NO.	PART NUMBER	DESCRIPTION	SERIAL NUMBER	NO REQ'D
1	1123810	LOCK NUT M8		2
2	1421824	FLAT WASHER M8× ϕ 24×2.0		4
3	8116009	PROTECTIVE WHEEL		2
4	8115404	BEARING, JOURNAL		2
5	1021616	HEX BOLT M6×16		2
6	1421612	FLAT WASHER M6× ϕ 12×1.6		2
7	1121008	HEX NUT M10		2
8	8118300	LEFT BRACKET		1
9	8310550	CASTER, 2 INCH		2
10	8310514	CLAMP ASSEMBLY		1
11	8310536	SQUEEGEE BLADE, REAR, LINATEX		1
	8310546	SQUEEGEE BLADE, REAR, PU (OPTION)		1
12	8310511	SQUEEGEE HOSING		1
13	1021835	BOLT, HEX HEAD, M8×35		2
14	8310512	RETAINER, SQUEEGEE		1
15	8310535	SQUEEGEE BLADE, FRONT, LINATEX		1
	8310545	SQUEEGEE BLADE, FRONT, PU (OPTION)		1
16	8210518	STAR KNOB M8		2
17	8118200	RIGHT BRACKET		1
18	8210525	SHORT CLAMP ASSEMBLY		1
19	1221575	SCREW M5×75		1
20	8118624	SHAFT		1
21	8118623	SPACER		1
22	1123507	LOCK NUT M5		1
23	8118109	HOLDER VACUUM HOSE		1
24	8118018	VACUUM HOSE		1
25	1962050	CLAMP		1
26	8310570	SQUEEGEE ASSEMBLY, 40.5 INCH		1

SOLUTION GROUP

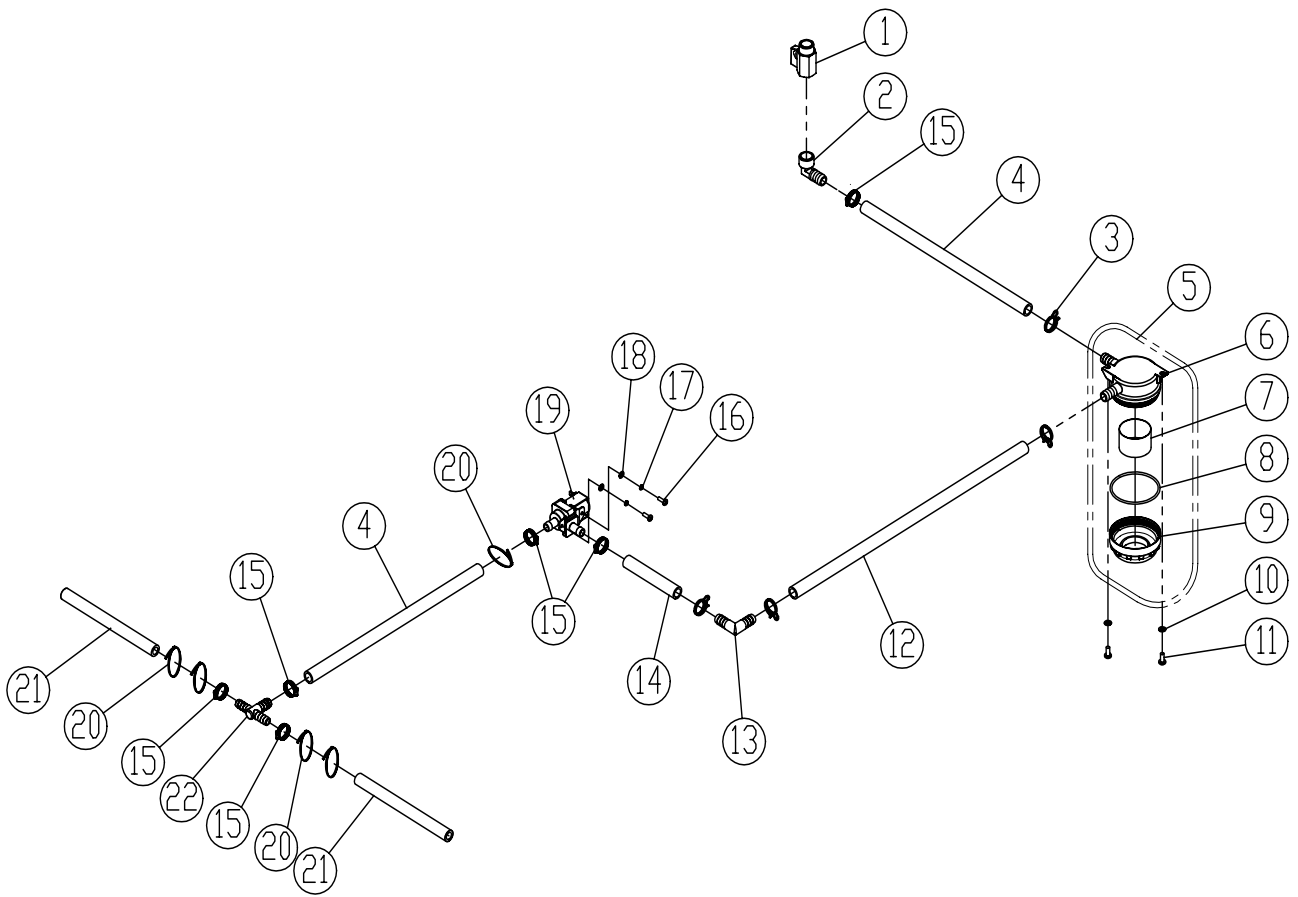

SOLUTION GROUP

DIA NO.	PART NUMBER	DESCRIPTION	SERIAL NUMBER	NO REQ'D
1	8119005	BALL VALVE, G1/2		1
2	8119007	ELBOW G1/2		1
3	8119006	CLAMP		4
4	8210901	TUBING ID=12MM L=330MM		2
5	8119200	FILTER ASSEMBLY		1
6	8119101	BASE, FILTER ASSEMBLY		1
7	8119104	SCREEN, FILTER, 40 MESH		1
8	1622063	O RING		1
9	8119102	CAP, FILTER ASSEMBLY		1
10	1421510	FLAT WASHER M5×10×1		2
11	1221512	SCREW M5×12		2
12	8210902	TUBING ID=12MM L=480MM		1
13	8119002	ELBOW, TUBING BARB		1
14	8210903	TUBING ID=12MM L=120MM		1
15	1962016	CLAMP, 10-16mm		6
16	1221412	SCREW M4×12		2
17	1422411	LOCK WASHER M4		2
18	1421409	FLAT WASHER M4×9×0.8		2
19	8119003	SOLENOID VALVE, 24VDC		1
20	1914300	TIE, NYLON, 5X300		5
21	8210904	TUBING ID=10MM L=180MM		2
22	8119008	FITTING, PLASTIC, TEE		1

CYLINDRICAL SCRUB HEAD GROUP

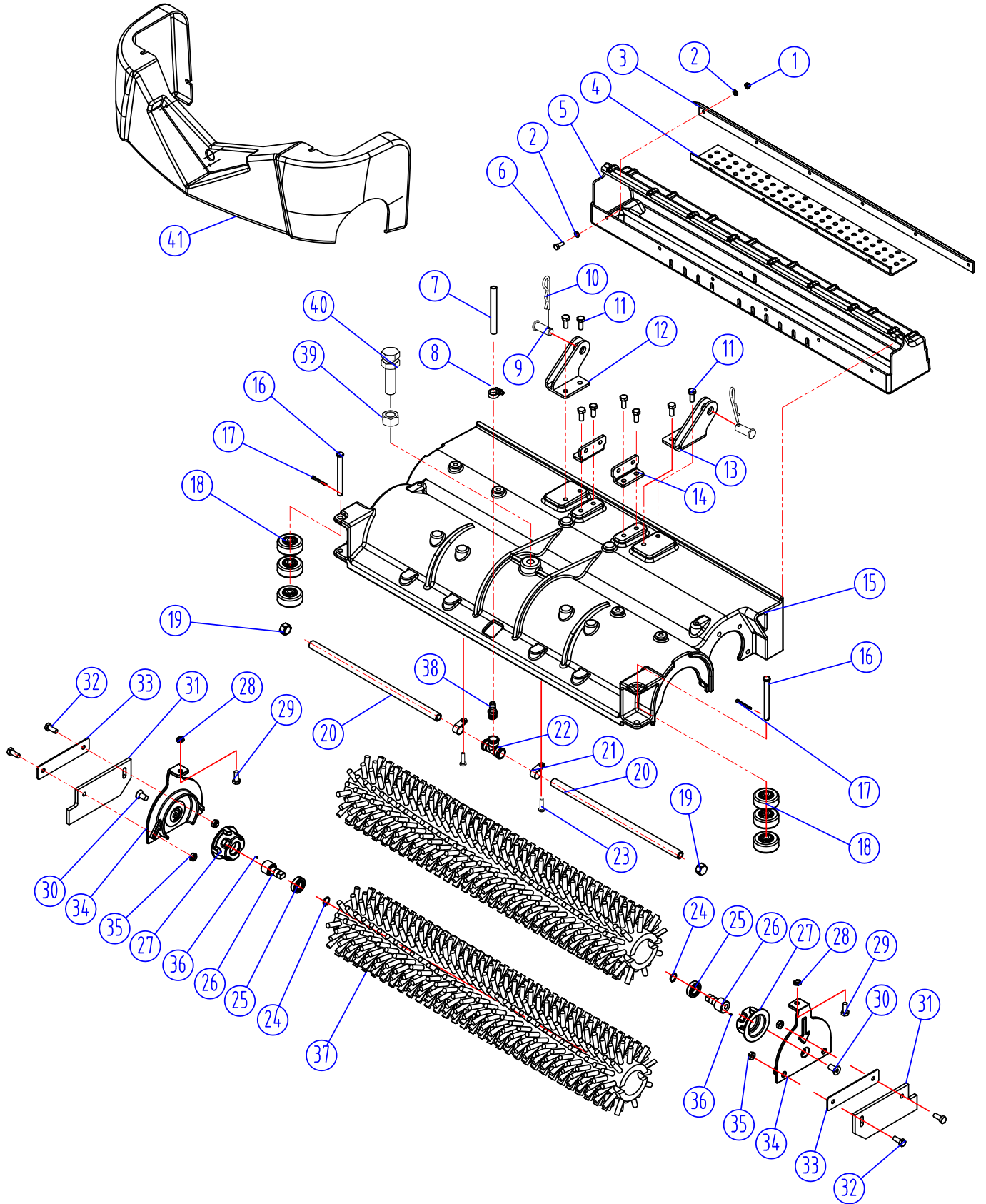

CYLINDRICAL SCRUB HEAD GROUP

DIA NO.	PART NUMBER	DESCRIPTION	SERIAL NUMBER	NO REQ'D
1	1123608	LOCK NUT, M6		6
2	1421612	FLAT WASHER, M6 X 12 X 1.6		12
3	8216107	LIP, HOPPER		1
4	8236020	STRIP, HOPPER		1
5	8216104	HOPPER, 28"		1
6	1021616	HEX BOLT, M6 X 16		6
7	8216113	TUBING, ID=12 X 550MM		1
8	1962016	CLAMP, 16MM		1
9	8210807	PIN		2
10	8210309	PIN, COTTER		2
11	1021820	SCREW, M8 X 20		8
12	8216110	BRACKET, SCRUB HEAD LIFT, LEFT		1
	8216116	BRACKET, SCRUB HEAD LIFT, LEFT		1
13	8216109	BRACKET, SCRUB HEAD LIFT, RIGHT		1
	8216115	BRACKET, SCRUB HEAD LIFT, RIGHT		1
14	8216111	BRACKET, ACTUATOR MOUNTING		2
15	8216101	HOUSING CYLINDRICAL, 28"		1
16	8236011	PIN, M9.5X96		2
17	1645324	PIN, COTTER, M3.2 X 24		2
18	8236026	WHEEL, 2"		6
19	8146303	END CAP, 3/8"		2
20	8216108	PVC TUBING		2
21	8146305	PLASTIC CLAMP		4
22	8146301	TEE FITTING, 3/8"		1
23	1221512	SCREW, M5 X 12		4
24	1436015	RING RETAINING, M15		2
25	1612602	BEARING, 6002LLU		2
26	8236009	SHAFT, IDLER		2
27	8236008	PLUG, IDLER,BRUSH		2
28	1121804	NUT, M8		2
29	1021840	SCREW, M8 X 40		2
30	1513020	COUNTERSUNK HEX SCREW, M10X20		2
31	8236013	SKIRT, CYLINDRICAL		2
32	1021816	SCREW, M8 X 16		4
33	8236014	CLAMP, SKIRT		2
34	8236002	DOOR, BRUSH		2
35	1123810	LOCK NUT, M8		4
36	1644206	PIN, M2.5X6		2
37	8216105	BRUSH, CYLINDRICAL, 28"		2
38	8013007	TUBING FITTING		1
39	1111215	HEX NUT, M16		1
40	8210811	AJUSTMENT STUD, M16		1
41	8216103	FRONT COVER		1

CYLINDRICAL SCRUB DRIVE GROUP

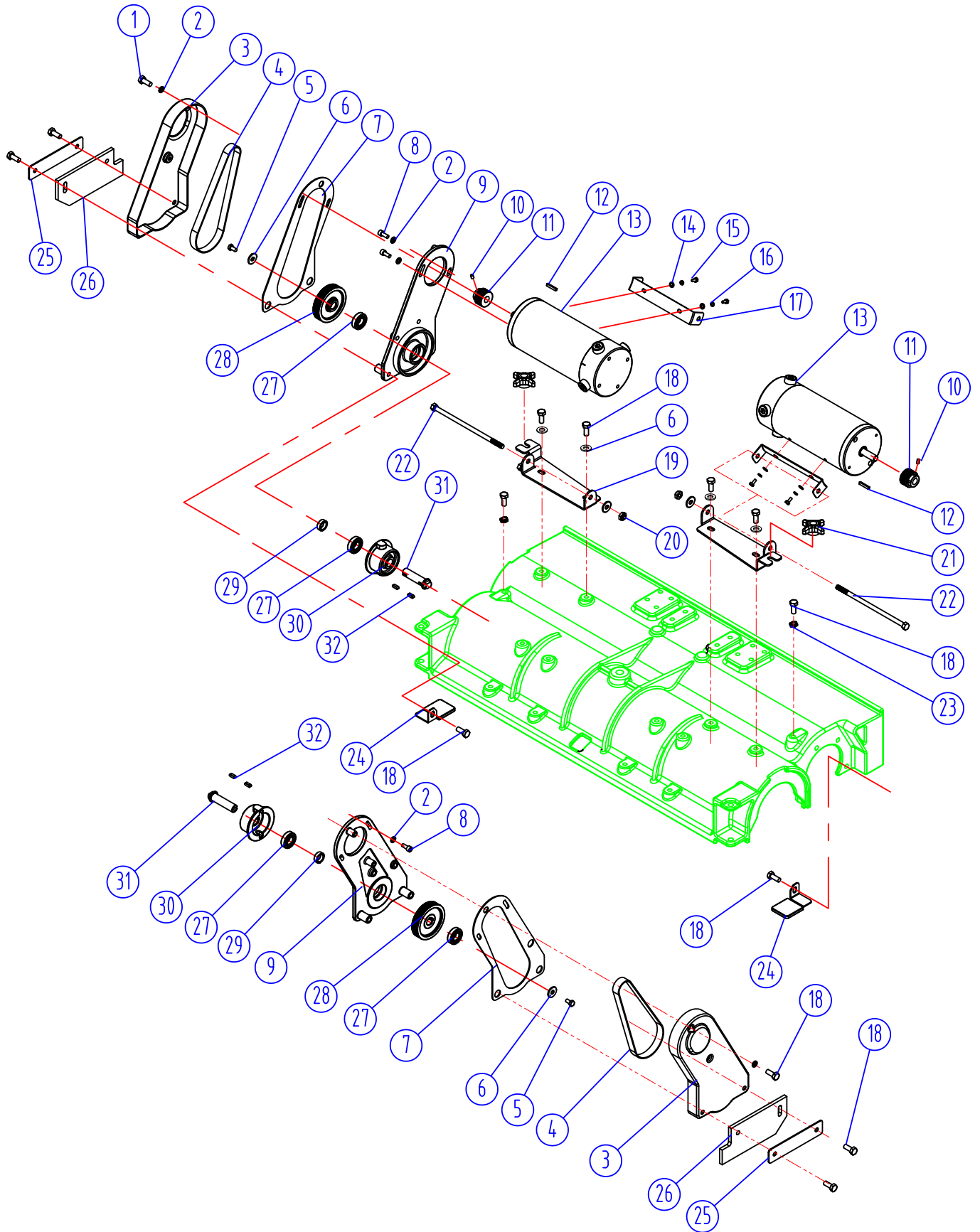

CYLINDRICAL SCRUB DRIVE GROUP

DIA NO.	PART NUMBER	DESCRIPTION	SERIAL NUMBER	NO REQ'D
1	1521612	HEX SOCKET SCREW, M6 X 12		4
2	1421612	FLAT WASHER, M6 X 12 X 1.6		8
3	8236018	COVER, BELT		2
4	8236027	BELT, DRIVE,6PJ 508MM		2
5	1021816	HEX BOLT, M8 X 16		2
6	1421824	FLAT WASHER, M8 X 24 X 2		8
7	8236029	GASKET, BELT		2
8	1521616	HEX SOCKET SCREW, M6 X 16		4
9	8236017	BRACKET, MOTOR MOUNTING		2
10	1534508	SCREW, M5 X 8		4
11	8236012	DRIVING PULLEY, 6PJ		2
12	8236023	KEY, 4 X 4 X 25		2
13	8216102	MOTOR, 24VDC,0.75HP		2
14	1421511	FLAT WASHER, M5 X 12 X 1		4
15	1021512	HEX BOLT, M5 X 12		4
16	1422513	WASHER, LOCK, M5 X 12 X 1		4
17	8236015	ANGLE BRACKET, MOTOR		2
18	1021820	HEX BOLT, M8 X 20		18
19	8236016	BRACKET, MOTOR		2
20	1123810	LOCK NUT, M8		2
21	8118003	STAR KNOB, M8		2
22	8236034	HEX BOLT, M8 X 185		2
23	1121804	NUT, M8		2
24	8236021	DEFLECTOR, WATER		2
25	8236014	CLAMP, SKIRT		4
26	8236013	SKIRT, CYLINDRICAL		4
27	1612602	BEARING, 6002LLU		4
28	8236007	DRIVEN PULLEY, 6PJ		2
29	8236024	BUSHING		2
30	8236025	PLUG, DRIVE, BRUSH		2
31	8236010	SHAFT		2
32	1655015	KEY,5 X 5 X 15		4

PARTS LIST

Transaxle Terminal Group

FOR SINGAL WIRE

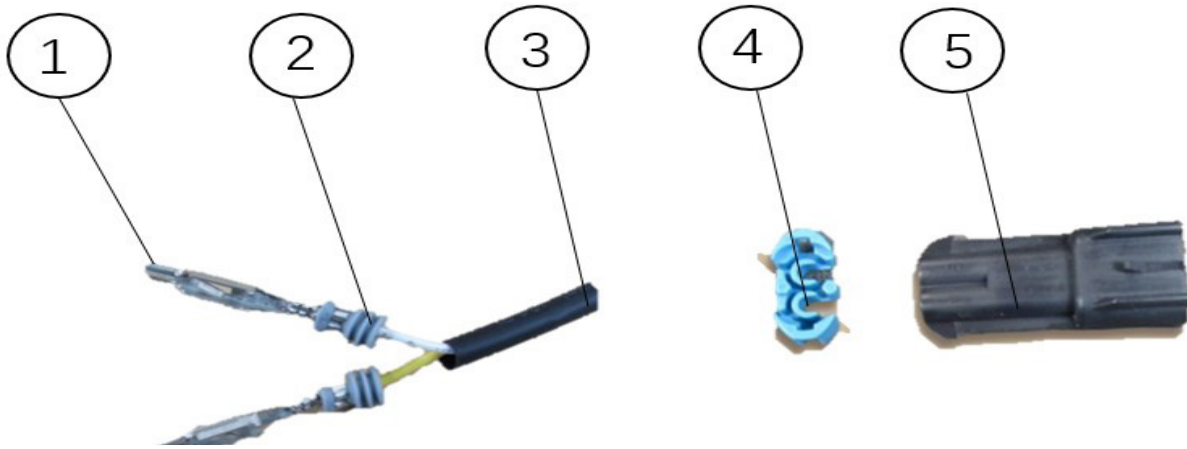

DIA NO.	PART NUMBER	DESCRIPTION	SERIAL NUMBER	NO REQ'D
1	1883073	280 TERMINAL		2
2	1883062	SHIELD		2
3	1884004	HEAT SHRINKABLE SLEEVR		1
4	1883071	MALE TERMINAL SOCKET		1
5	1883072	BARRIER		1

FOR POWER CORD

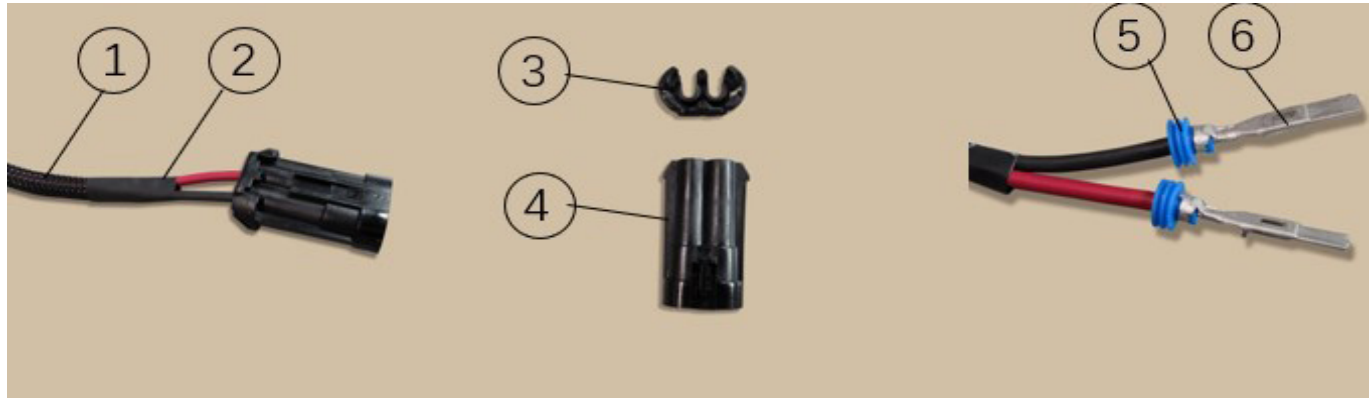

DIA NO.	PART NUMBER	DESCRIPTION	SERIAL NUMBER	NO REQ'D
1	1884108	BRAIDED SLEEVE		1
2	1884008	HEAT SHRINKABLE SLEEVR		2
3	1883038	MALE TERMINAL SOCKET		1
4	1883036	BARRIER		1
5	1883041	SHIELD		1
6	1883040	TERMINAL		2

DIA NO.	PART NUMBER	DESCRIPTION	NO REQ'D	PICTURE
1.	8134709	PROXIMITY SWITCH	1	
2.	1883101	CONNECTOR SEAL RING	3	
3.	1883100	150 TERMINAL	3	
4.	1883098	BARRIER	1	
5.	1883099	CONNECTOR SHELL	1	
1.	8310708	HORN, 24VDC	1	
2.	1883043	TERMINAL	2	
3.	1883045	2-BIT CONNECTOR SHELL	1	
4.	1883046	CONNECTOR SHELL	1	

WEAR AND TEAR PARTS

WEAR AND TEAR PARTS

DIA NO.	PART NUMBER	DESCRIPTION	NO REQ'D
1	8125200	WHEEL, 8 INCH	2
	8225200	AIR FILLED WHEEL, 8 INCH, KIT (OPTION)	2
	8225210	FOAM FILLED WHEEL, 8INCH, KIT (OPTION)	2
2	8116009	PROTECTIVE WHEEL	3
3	8210513	SQUEEGEE BLADE, FRONT, LINATEX	1
	8210516	SQUEEGEE BLADE, FRONT, PU (OPTION)	1
	8220514	SQUEEGEE BLADE, FRONT, LINATEX (OPTION)	1
	8220524	SQUEEGEE BLADE, FRONT, PU (OPTION)	1
	8310535	SQUEEGEE BLADE, FRONT, LINATEX (OPTION)	1
	8310545	SQUEEGEE BLADE, FRONT, PU (OPTION)	1
4	8210514	SQUEEGEE BLADE, REAR, LINATEX	1
	8210517	SQUEEGEE BLADE, REAR, PU (OPTION)	1
	8220513	SQUEEGEE BLADE, REAR, LINATEX (OPTION)	1
	8220523	SQUEEGEE BLADE, REAR, PU (OPTION)	1
	8310536	SQUEEGEE BLADE, REAR, LINATEX (OPTION)	1
	8310546	SQUEEGEE BLADE, REAR, PU (OPTION)	1
5	9050014	14" BRUSH , i28BTL	2
	9050016	16" BRUSH , i32BTL	2
6	9040014	14" PAD HOLDER, i28BTL	2
	9040016	16" PAD HOLDER, i32BTL	2
7	8216105	BRUSH, CYLINDRICAL, 28"	2

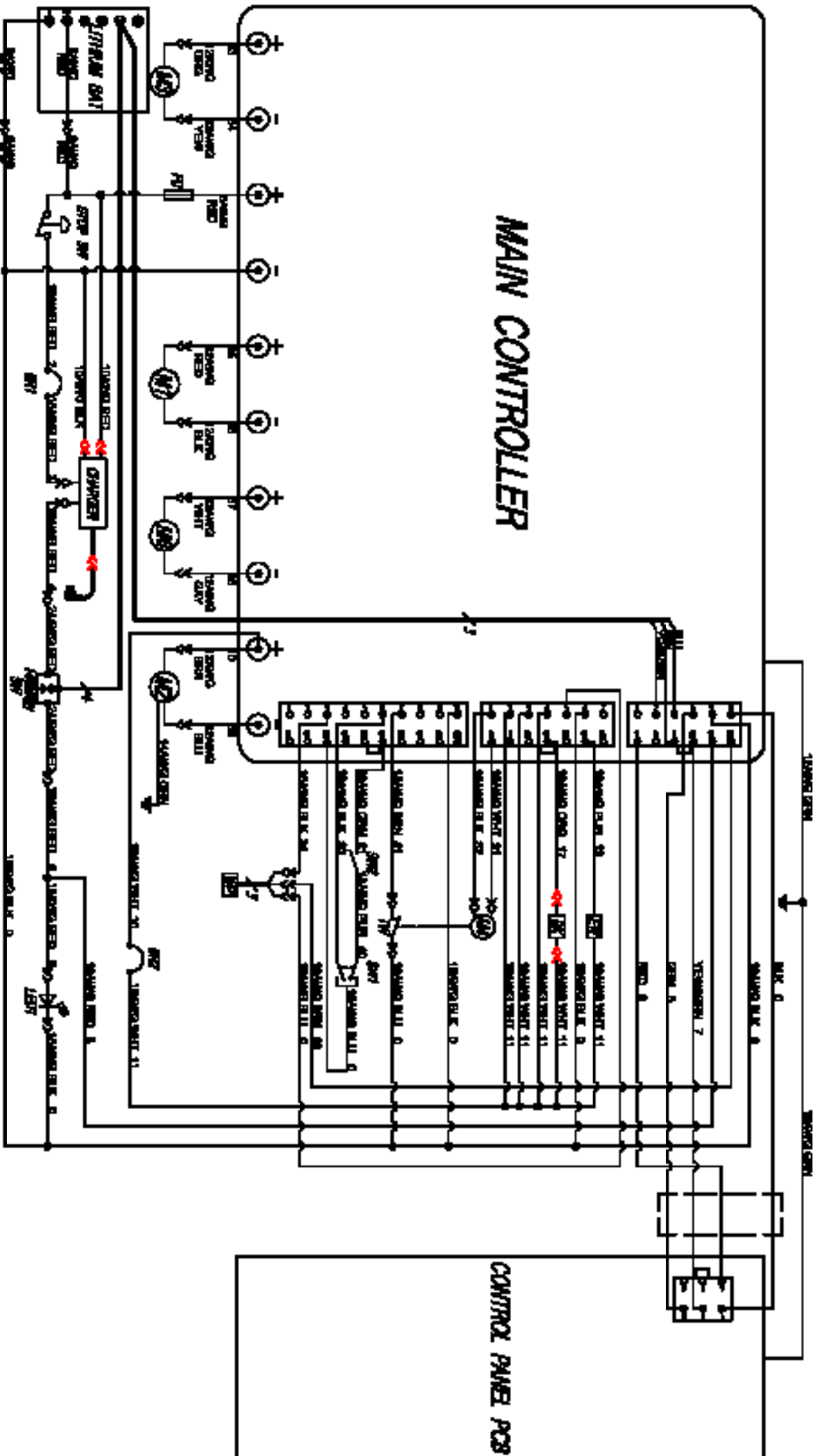

LITHIUM BAT: Lithium-ion batteries
 STOP SW: Emergency stop button
 BR1: Main controller circuit breaker, 5A
/>
 i-synergy SW: i-synergy Starting switch
 LED1: Working LED light
 CHARGER: On-board battery charger
 BR2: Circuit breaker, 5A
 M3: Traction motor

FU: 150A Fuse
 M1: Brush motor, Left
 M6: Brush motor, Right
 M2: Vacuum motor
 MAIN CONTROLLER: Main controller
 WP: Proximity switch
 SW1: Micro-switch, Forward
 SW2: Micro-switch, Backward

TW: Limit switch, Actuator
 M4: Actuator, Scrub head lift
 BK: Coil, Brake
 EW: Solenoid valve
 CONTROL PANEL PCB: Control panel PCB

CERTIFICATE OF QUALIFIED

MODEL : _____

SERIAL NO.: _____

INSPECTOR: _____

DATE : _____

ICE Cobotics (GuangDdong) Company Limited

TEL : (+86) 769 8186 9000

FAX : (+86) 769 8186 3000