

ICE USA

A DIVISION OF ICE COBOTICS

www.ice4usa.com



Operator & Parts Manual

Automatic Scrubber



i20NBTL+

i24BTL+

i-SYNERGY

Cleaning Management in Motion

8130130
REV.02 (05-2023)



READ OPERATOR MANUAL CAREFULLY!

IMPORTANT: To ensure full warranty protection, please fill out & return your warranty card.

Please fill out at time of installation for future reference.

Model No. _____

Serial No. _____

Machine Options _____

Sales Rep. _____

Sales Rep. Phone No. _____

Customer ID Number _____

Installation Date _____

HOW TO ORDER PARTS

Only use ICE Cobotics Company supplied or equivalent parts. Parts and supplies may be ordered online, by phone, by fax or by mail.

1. Identify the machine model.
2. Identify the machine serial number from the data label.
3. Ensure the proper serial number is used from the parts list.
4. Identify the part number and quantity.
Do not order by page or reference numbers.
5. Provide your name, company name, customer ID number, billing and shipping address, phone number and purchase order number.



PROTECT THE ENVIRONMENT

Please dispose of packaging materials, old machine components such as batteries, hazardous fluids, including antifreeze and oil, in an environmentally safe way according to local waste disposal regulations.



Always remember to recycle.

ICE Cobotics (GuangDdong) Company Limited

XiangShi Road LiaoBu DongGuan GuangDong China

Tel: 0769 - 81869000

Fax: 0769 - 81863000

Specifications and parts are subject to change without notice.

TABLE OF CONTENTS

SAFETY PRECAUTIONS.....	4
MACHINE COMPONENTS.....	5
PANEL COMPONENTS.....	6
i-synergy™ INTRODUCTION.....	7
MACHINE SETUP & INSTALLATION.....	7
MACHINE OPERATION.....	8
WHILE OPERATING MACHINE.....	8
TANK DRAINING.....	9
BATTERY CHARGING.....	9
PREVENTATIVE MAINTENANCE.....	10
FAULT CODE & SOLUTION.....	11
BASIC TROUBLESHOOTING.....	12
TECHNICAL SPECIFICATIONS.....	13
PARTS LIST.....	14-40
WEAR AND TEAR PAR.....	41
WIRING DIAGRAM	42

SAFETY PRECAUTIONS

This machine is intended for commercial use. It is designed exclusively to scrub hard floors in an indoor environment and is not constructed for any other use. Only use recommended accessories.

All operators shall read, understand and exercise the following safety precautions:

1. Do not operate machine:

- Unless trained and authorized.
- Unless you have read and understand the operators manual.
- In flammable or explosive areas.
- If not in proper operating condition.
- In outdoors areas.

2. Before starting machine:

- Make sure all safety devices are in place and operate properly.

3. When using machine:

- Go slow on inclines and slippery surfaces.
- Follow all safety guidelines.
- Be very careful when using the machine in reverse.
- Reduce speed when turning.
- Report and fix any damage to machine prior to operating it.
- Never allow children to play on or around.
- Do not operate on inclines that exceed 5% (3°).

4. Before leaving or servicing machine:

- Stop on level surface.
- Turn off machine.

5. When servicing machine:

- Read operators manual thoroughly prior to operating or servicing this machine.
- Use manufacturer supplied or approved replacement parts.
- Secure machine with wheel blocks prior to jacking the machine up.
- Use approved jack or hoist to safely elevate the machine.
- Disconnect batteries prior to working on machine.
- Avoid moving parts. Do not wear loose fitting clothing while servicing machine.

 **WARNING: Fire or Explosion Hazard. Keep sparks and open flames away! Keep battery compartment open when charging.**

 **WARNING: Flammable materials can cause an explosion or fire. Do not use flammable materials in tanks.**

 **WARNING: Flammable materials or reactive metals can cause explosion or fire. Do not pick up.**

MACHINE COMPONENTS

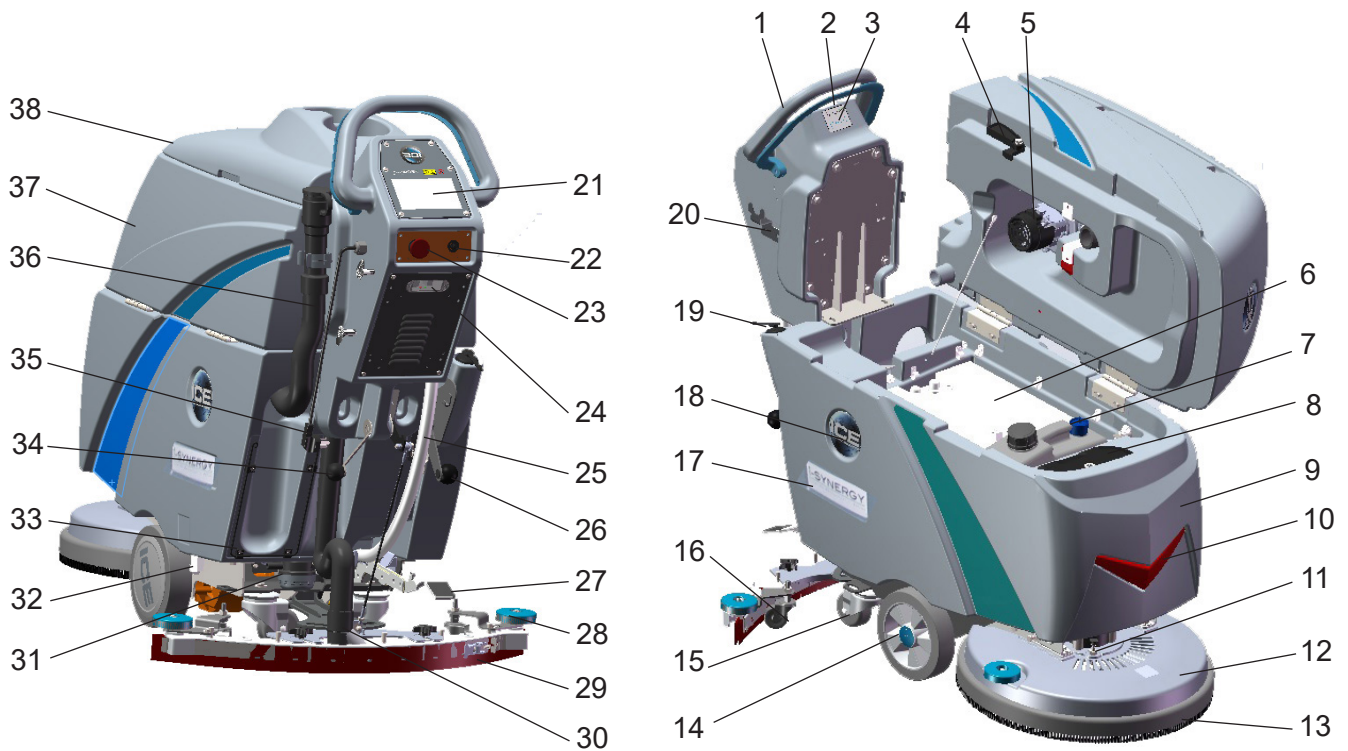

- | | |
|--|---|
| <ul style="list-style-type: none"> 1. Control Handle 2. Control Handle Start Bail 3. i-synergy™, ID card scanning area 4. Recovery Tank Support Stand 5. Vacuum Motor, 24VDC 6. Lithium-ion Batteries 7. Cleaner Group (Option) 8. Bucket Fill Port/ Clean-Out Port 9. Solution Tank 10. LED Light 11. Motor Hub Lock Pin (Disk Models) 12. Scrub Head Assembly 13. Scrub Head Skirt 14. Wheels, 8 Inch 15. Caster, 3.15 Inch 16. Caster, 2 Inch, Squeegee Blade Adjustment 17. i-SYNERGY decal 18. ICE Logo 19. Hose Fill-Port | <ul style="list-style-type: none"> 20. Squeegee Storage Bracket 21. Control panel (see Panel components) 22. Main controller breaker 23. Emergency Stop Button (Drive Models) 24. On-board battery charger / Window 25. Solution Tank Level / Drain Hose 26. Heavy Down Pressure Lever 27. Scrub Head Lift Pedal 28. Bumper Rollers 29. Squeegee Assembly 30. Squeegee Vacuum Hose 31. Filter Assembly 32. Ball Valve 33. Cargo Mesh Bag 34. Squeegee Lift Lever 35. Power cord, on-board Battery charger 36. Recovery Tank Drain Hose 37. Recovery Tank 38. Recovery Tank Cover |
|--|---|

PANEL COMPONENTS(i20NBTL+/i24BTL+)

NO detergent

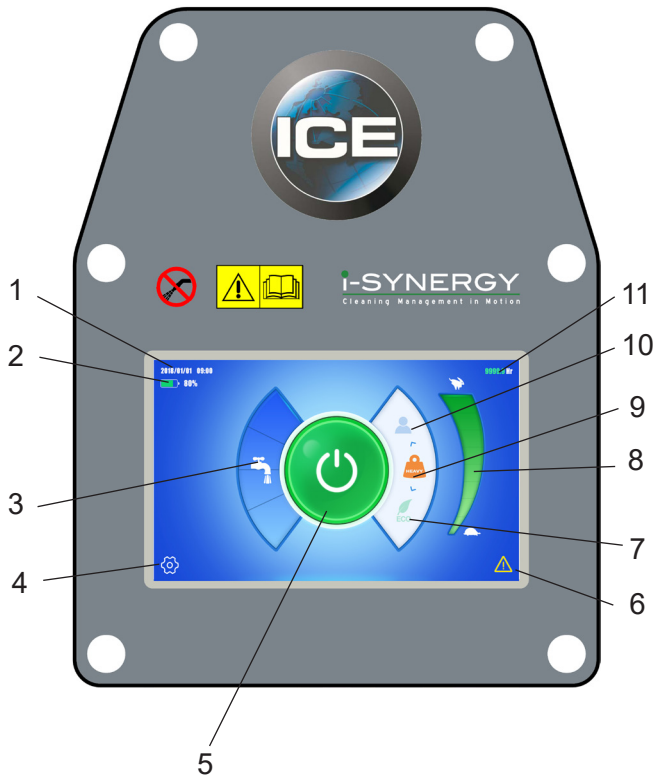

Have detergent

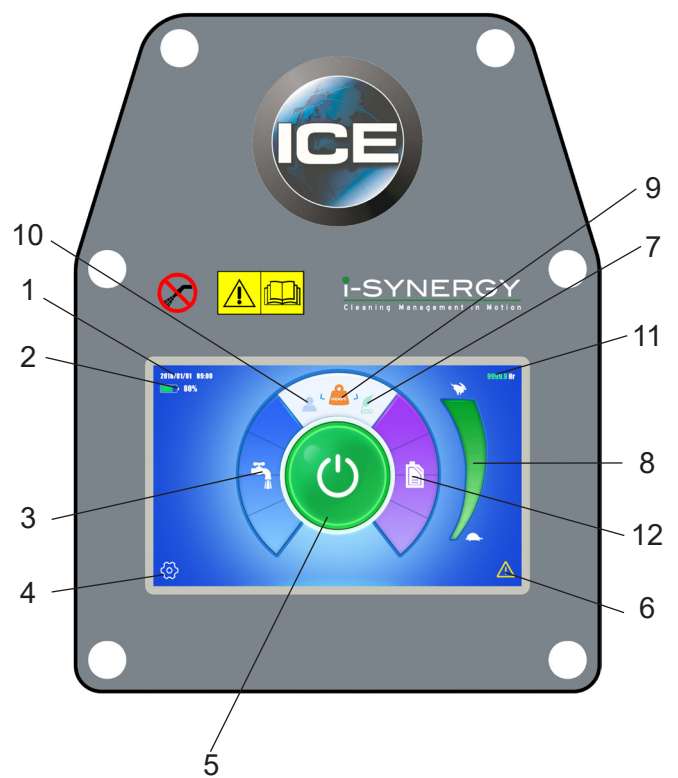

- 1. Calendar time
- 2. Battery meter
- 3. Solution flow control button
- 4. Setting
- 5. Vacuum motor switch
- 6. Fault indicator
- 7. Power saving
- 8. Speed control button

- 9. Heavy load
- 10. Custom Pattern
- 11. Timer
- 12. Regulating detergent

i-synergy™ INTRODUCTION

i-synergy™ collects operational data from cleaning machines and transmit the information to ICE's server. The ICE server generates daily reports and send them to designated end users by email. From these reports, end users will have information about machines' usage and even specific timings.

Besides, i-synergy™ also collects data on lithium-ion battery, vacuum motor, brush deck motor, transaxle, and other electrical components at least once every minute when the machine is in use and even during battery charging.

i-synergy™ will send notifications instantly to the ICE server in case of any malfunction. ICE maintenance personnel will receive a SMS within minutes from the ICE server for immediate servicing.

MACHINE SET UP & INSTALLATION

UNCRATING MACHINE

Be sure and check packing carton for any damage. Immediately report any damage to carrier. Check the contents of package to ensure that the following items are included:

- Machine
- Lithium-ion Batteries
- Squeegee assembly
- Battery Charger
- Pad Driver
- Brush

INSTALLING BATTERIES

The machine uses the Lithium-ion batteries, the batteries are already in the machine upon delivery; However you will need to connect the Lithium ion batteries to the machine.



WARNING: Fire or Explosion Hazard. Keep sparks and open flames away! Keep battery compartment open when charging.

1. Turn off the machine.
2. Open recovery tank to gain access to battery compartment.
3. Carefully place the Lithium-ion batteries into the compartment. Place the battery brace at the rear of the batteries.

DO NOT DROP BATTERIES INTO COMPARTMENT!

4. Plug the batteries connector to the machine adaptor, connect machine i-synergy™ COM port with the batteries.

MACHINE SET UP

PRE-OPERATION CHECKS

1. Sweep or dust mop the surface to be cleaned.
2. Check battery meter to make sure batteries are fully charged. (See BATTERY CHARGING).
3. Check that squeegee is properly installed.
4. Check that brush / pad is properly installed.

INSTALLING PAD DRIVER OR BRUSH

1. Ensure that the machine is turned off.
2. Step down on the scrub head lift pedal (see machine components, item #26) to raise the scrub head off the floor.
3. If using a Pad Driver, first attach the appropriate pad to the pad driver surface.
4. Turn the brush motor hub until the slot with the spring clip is visible through the scrub head window.
5. Mount the pad driver or brush to the brush motor hub by lining up the three studs with the three holes in the brush motor hub. Once in the holes, rotate the driver toward the spring clip to lock the pad driver into place.
If necessary, press down on the motor hub lock pin (see machine componts, item # 10) to lock motor hub in place.
6. For Orbital head Model i20NBTL+-OB, you need to attach a rectangular, 20in(508mm)×14in(356mm) Pad to the Orbital Pad driver. Align the pad to the Orbital pad driver, press from front-to-back and side to side to alignment.

MOUNTING THE SQUEEGEE ASSEMBLY

1. Lift the squeegee lift lever (see machine components, item #33) to the upward position.
2. Mount the squeegee assembly to the squeegee pivot bracket. Make sure the knobs are completely seated into the slots before securing knobs.
3. Connect the vacuum hose to the squeegee assembly. Loop the hose by using the hose clip provided.
4. Check the squeegee blades for proper adjustment.

OPERATOR MANUAL

FILLING THE SOLUTION TANK

The machine is equipped with a hose fill-port (see machine components, item #18) at the rear of the machine, and a bucket fill-port (see machine components, item #7) located under the recovery tank. Before accessing the bucket fill-port make sure that the recovery tank is empty.

Fill the solution tank to the "60L" level on the solution tank sight gauge. When using the bucket fill-port, stop filling when the level reaches the bottom edge of the fill-port.

Conventional scrubbing - Fill solution tank with water (not to exceed 60°C/140°F. Pour a recommended cleaning detergent into the solution tank according to mixing instructions on the container)

NOTE: When filling the solution tank with a bucket, make sure that the bucket is clean. Do not use the same bucket for filling and draining the machine.

 **WARNING:** Do not put any flammable materials into solution tank. this can cause an explosion or a fire. Only use recommended cleaning chemicals. Contact your janitorial supply distributor for recommendations on proper chemicals.

MACHINE OPERATION

 **WARNING:** Do not operate machine unless you have read and understand this manual.

1. Lower squeegee assembly to the floor by lowering the squeegee lift lever(see machine components, item #33).
2. Lower the scrub head to the floor by stepping on the scrub head lift pedal(see machine components, item #26).
3. Swiping the ID card (see machine components, item #3) to turn on the machine.
4. Check the battery meter (see Panel components, item #2), if the battery is very low, there will be a Fault code & message on the LED display screen(see Fault code section), and the Fault indicator will blink continuously accompany an audible alarm. please DO NOT continue to operate the machine and recharge the batteries immediately.
5. Check the solution flow indicator (see Panel components, item #5), press the solution flow control button (see Panel components, item #6, 7) to a desired flow rate.

NOTE: Solution will not begin to flow until the control handle bail is pulled.

6. Turn on the vacuum motor switch(see Panel components, item #10).
7. i20NBL+: Pull the control handle bail(see machine components, item #2) backwards to start

scrubbing by moving the machine forward.

The drive model i20NBTL+ / i24BTL+: Pull the control handle bail (see machine components, item #2) backwards to start scrubbing. The machine will automatically propel forward. To reverse the drive model, simply push the control handle bail forward. The speed can be adjusted, Adjust the speed control button (see Panel components, item #13, 15) to a desired scrubbing speed.

NOTE: 45-60 meters (150-200 ft)per minute is the recommended scrubbing speed.

8. When more brush pressure is needed for heavily soiled areas simply lift the down pressure lever(see machine components, item #25).
9. To stop scrubbing, release the control handle bail, raise the scrub head and the squeegee assembly.

WHILE OPERATING MACHINE

 **WARNING:** Fire Or Explosion Hazard. Do Not Pick Up Flammable Materials Or Reactive Metals.

1. Go slow on inclines and slippery surfaces. Do not operate the machine on inclines that exceed 5% (3°).
2. Do not keep the machine in the same position with pad / brush spinning, keep the machine moving to prevent damage to floor finish.
3. If the squeegee assembly leaves streaks on the floor, raise the squeegee off the floor and wipe the blades down with a damp cloth. Pre-sweep the area to prevent leaving streaks on the floor.
4. Pour a recommended defoamer into the recovery tank if excessive foam appears.

 **WARNING:** Do not allow foam to enter the float shut-off screen, vacuum motor damage will result. Foam will not activate the float shut-off screen.

5. Occasionally check the battery meter(see Panel components, item #2). when the battery is very low, stop scrubbing and recharge the batteries.

 **WARNING:** When battery is very low, do not continue to operate the machine. Battery damage may result.

6. When the solution tank runs empty, raise the brush head off the floor. Keep the squeegee down and continue to vacuum until all the dirty water is picked up.

NOTE: See **TANK DRAINING** section to learn how to drain recovery and solution tanks.

CIRCUIT BREAKER

The machine is equipped with a resettable circuit breaker(see machine components, item #22) to protect the Main controller. If the circuit breaker should trip, it can't be reset immediately. You must first determine what caused the breaker to trip, and allow the Controller to cool down and then you can manually reset the circuit breakers.

NOTE: Contact a Authorized Service center for machine repairs.

HOOR METER

The hour meter (see Panel components, item #12) records the number of total hours the brush motor has been powered on. Use the hour meter to determine when to perform recommended maintenance procedures and to record service history.

TANK DRAINING

1. Turn the machine off.
2. With the squeegee and scrub head in their "up" position, transport machine to approved area for draining tank(s).

DRAINING THE RECOVERY TANK

Any time scrubbing is completed, or when refilling solution tank, the recovery tank should be drained and cleaned.

 **WARNING: If the recovery tank is not drained when the solution tank has been refilled, foam or water may enter the float shut-off screen and cause damage to the vacuum motor.**

1. While holding the drain hose (see machine components, item #35) upward, remove the cap and lower hose to drain.
2. Open the recovery tank cover and rinse out the tank. Use a rag to remove any excess dirt.
3. Clean the float shut-off screen and debris tray located in the recovery tank .

DRAINING THE SOLUTION TANK

Any time scrubbing operation is completed, the solution tank should be drained and cleaned.

1. Pull the solution tank level hose(see machine components, item #24) off the hose fitting, this will allow the solution to flow freely into a bucket or floor drain.
2. Remove the cover of the filter assembly(see machine components, item #30) to drain the solution tank, check the filter screen and clean up it if necessary.
3. Rinse the solution tank with clean water after every use. This will help prevent chemical buildup and clogging of the solution lines.
4. After rinsing out the tank, securely reconnect the tank level hose to the hose fitting, replace the filter assembly cover and be sure the filter screen and the "O" ring is in the correct position.

BATTERY CHARGING

 **WARNING: Fire Or Explosion Hazard. Keep Sparks and Open Flame Away. Keep Battery Compartment Propped Open When Charging.**

Only use ICE supplied or approved batteries charger, use unapproved charger may cause damage to the batteries and machine.

Batteries charger specifications:

- **Applicable to charging Lithium-ion batteries**
- **Automatic shut off circuit**
- **Output current of 15 Amps**
- **Output voltage of 24 volts**

1. Place machine in a well ventilated area.
2. Turn the machine off.
3. Connect the charger's AC power supply cord (see machine components, item #34)to a properly grounded receptable.
4. Prop up the recovery tank by the support stand (see machine components, item #4) for ventilation when charging.
5. The charger will automatically begin to charge and will automatically shut off once the batteries are fully charged.
6. Upon completion of charging, disconnect the AC power supply cord.

PREVENTATIVE MAINTENANCE

⚠ WARNING: Before performing any maintenance on the machine, be sure that the power is turned off, or the batteries are disconnected!

⚠ WARNING: Repairs are to be completed by Authorized service centers only. Any repairs completed by unauthorized persons will void the warranty.

DAILY MAINTENANCE

1. Remove pad driver/ brush and clean with approved cleaner.
2. Drain recovery and solution tanks completely and rinse out with clean water. Visually check the recovery tank for debris and clean out as necessary.
3. Raise the squeegee assembly off floor and wipe it down with a damp towel. Be sure to store the squeegee in the up position.
4. Remove the float shut-off assembly and rinse it out with clean water.
5. Clean machine with an approved cleaner and a damp towel.
6. Recharge the batteries.
7. Check the condition of the squeegee blade wiping edge, rotate blade if worn.

MONTHLY MAINTENANCE

1. Clean the battery tops to prevent corrosion.
2. Check for loose battery cable connections.
3. Inspect and clean the recovery tank cover seal. Replace it if damaged.
4. Lubricate all grease points and pivot points with silicon spray and approved grease.
5. Check the machine for loose nuts and bolts.
6. Check the machine for leaks.

ORBITAL HEAD MAINTENANCE

For Orbital head, you should have checked the eight isolators located in the Orbital head every 300 hours.

1. Using a flashlight, do a visual inspection of the isolators by looking through the opening in the Orbital head and checking for wear or damage to four isolators in the front and four in the rear of the Orbital head. The locations of the isolators are shown below.

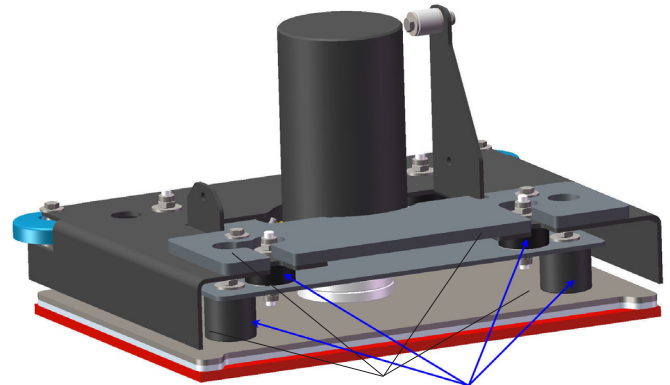

ISOLATORS (8)

2. If any of the eight isolators show signs of wear, degradation or damage, contact your local distributor to replace all eight isolators.

MACHINE STORAGE

1. Always store the machine indoors.
2. Always store the machine in a dry area.
3. Always store the machine in its upright position.
4. Always store the machine with the pad driver/ brush raised off the floor.
5. Always store the machine with the squeegee assembly raised off the floor.
6. If storing in an area which may reach freezing temperatures, be sure to drain all fluids from the machine prior to storage. Any damage caused by freezing temperatures will not be covered by the warranty.
7. Drain the recovery tank.
8. Drain the solution tank of all fluid.

FAULT CODE & SOLUTION

The machine is equipped with a LED display screen (see Panel components, item # 4), the LED screen will display the operating hours (see Panel components, item # 12) and the battery level status (see Panel components, item # 2).

When the machine detects a fault, there will be a Fault code (see Panel components, item #11) & Fault message (see Panel components, item #8) display on the LED screen, and the Fault indicator (see Panel components, item #1) will flash continuously, accompany an audible alarm Occasionally.

Once fault occurring, please DO NOT continue operate the machine unless the fault are eliminated. Turn off the machine, then to solve the fault, the fault code & message will be eliminated when machine restart.

If the fault is occurred frequently, or the fault can't be eliminated, please contact ICE service center.

Please refer to the below table to determine the fault cause and the solution.

FAULT CODE	FAULT MESSAGE	MODEL		FAULT CAUSE	SOLUTION
			i20NBTL+ i24BTL+		
F01	Lower Brush Deck			Brush deck is off the floor	Release the control handle bail Or Lower the Brush deck
F04	Vac Mtr O.L. RE-START!		●	Vacuum motor overload	Turn off the machine,after a moment, RE-START machine
F06	Bru Mtr O.L. RE-START!		●	Brush motor overload	
F07	Propel Mtr O.L. RE-START!		●	Propel motor overload	
F10	Batt Low Charge Batt		●	Battery is low	Charge the battery
F11	Batt Empty Charge Batt NOW		●	Battery is empty	Charge the battery NOW
F12	Brake Wiring Error		●	Bad Brake wiring Bad Brake	Check the brake wiring Replace the Brake assembly
F14	Replace Brake Assy		●	Bad Brake assembly	Replace the brake assembly
F16	Control Unit Overheat! Wait		●	Control Unit Overheat	Turn off the machine,after a moment, RE-START machine
F17	Replace Control Unit		●	Control Unit Fault	Replace the control unit
F20	Check Brush Motor		●	Bad brush motor	Check the brush motor / Wiring
F21	Check Vac Mtr		●	Bad Vacuum motor or wiring	Check the vacuum motor / Wiring
F22	Check Soln Solenoid		●	Solution solenoid wiring fault	Check the wiring & Contactors
F23	Replace Soln solenoid		●	Bad Solution solenoid	Replace the solution solenoid
F24	Check Propel Motor		●	Bad propel motor	Check the propel motor / Wiring
F25	Check Brush Motor			Bad brush motor	Check the brush motor / Wiring
F40	Check Proximity Sw		●	Proximity switch fault	Check the Proximity switch
F41	Release Handle		●	Operation mistake	Release the control handle bail
F42	Replace Control Unit		●	Bad Control Unit	Replace the control unit
F43	Turn Dead Sw Off RE-START!		●	Emergency stop button activated.	Release emergency stop button and restart machine.
F44	Replace Control Unit		●	Bad Control Unit	Contact service center, Replace the Control Unit
F45	Return Control Unit		●		
F46	Return Control Unit		●		
F47	Return Control Unit		●		
F48	Return Control Unit		●		

BASIC TROUBLESHOOTING

PROBLEM	CAUSE	SOLUTION
Machine will not operate	Control handle bail not pulled	Pull control handle bail
	Lithium-ion batteries need to be charged	Charge batteries
	Bad lithium-ion batteries	Replace batteries
	Loose batteries connection	Tighten the connector
	Main control unit circuit breaker tripped	Reset main control unit breaker
	Faulty i-synergy™ module	Contact ICE service center
Brush motor will not operate	Scrub head is raised off floor	Lower scrub head
	Faulty scrub head (up/down)switch	Contact ICE service center
	Faulty control handle bail switch	Contact ICE service center
	Faulty brush motor or wiring	Contact ICE service center
	Worn Motor carbon brushes	Contact ICE service center
Machine does not propel (Drive model)	Faulty transaxle motor or wiring	Contact ICE service center
	Worn Motor carbon brushes	Contact ICE service center
Vacuum motor will not operate	Faulty vacuum motor or wiring	Contact ICE service center
	Worn Motor carbon brushes	Contact ICE service center
Little or no solution flow	Ball valve set too low or shut off	Turn on the ball valve
	Solution flow control knob set too low or shut off	Adjust solution control flow knob
	Clogged solution tank filter or solution hose	Clean solution tank filter or flush out solution hose
	Clogged solution Solenoid valve	Remove valve and clean
Poor water pick up	Recovery tank is full	Drain recovery tank
	Loose drain hose cap	Tighten cap
	Clogged float shut-off screen located in recovery tank	Clean screen
	Clogged squeegee assembly	Clean squeegee assembly
	Worn squeegee blades	Replace or rotate squeegee blades
	Incorrect squeegee blade deflection	Adjust squeegee blade height
	Loose vacuum hose connections	Secure hose connections
	Clogged vacuum hose	Remove clogged debris
	Damaged vacuum hose	Replace vacuum hose
	Recovery tank cover not in place	Properly position cover
	Damaged recovery tank cover seal	Replace seal
	Faulty vacuum motor	Contact ICE service center
	Low battery charge	Recharge batteries
Short run time	Low battery charge	Fully recharge batteries
	Defective batteries	Replace batteries
	Faulty battery charger	Repair or replace battery charger
	Down pressure lever is set for extra scrub head pressure	Lower down pressure lever

TECHNICAL SPECIFICATIONS

MODEL	i20NBTL+ W/ Drive	i24BTL+ Dual disk
DIMENSIONS L	55.7 in / 1,415 mm	52.2 in / 1,325 mm
DIMENSIONS W	22 in / 560 mm	25.6 in / 650 mm
DIMENSIONS H	44.9 in / 1,140 mm	44.9 in / 1,140 mm
WEIGHT	230 lbs / 105 Kg	
WEIGHT with BATTERIES	330 lbs / 150 Kg	
RECOVERY TANK CAPACITY	17.2 Gal / 65 L	
SOLUTION TANK CAPACITY	15.9 Gal / 60 L	
SQUEEGEE WIDTH	30 in / 762 mm	
CLEANING PATH WIDTH	20 in / 500 mm (Disk)	24 in / 600mm
PRODUCTIVITY RATE	23,680 ft ² / 2,200 m ² h	28,000 ft ² / 2,600m ² h
DRIVE SYSTEM	Transaxle, 0.27 hp / 0.2KW	
TRAVEL SPEED, MAXIMUM	N/A	246 ft / Min 75 m / Min
MINIMUM AISLE TURN	63 in / 1,600 mm	
PAD/BRUSH PRESSURE	65 lbs / 30 Kg Min 100 lbs / 45 Kg Max	
SOLUTION FLOW RATE	0 ~ 0.37 Gal / Min 0 ~ 1,400 ml / Min	
BRUSH MOTOR	0.75hp / 0.55KW 220 RPM	0.9hp / 0.68KW 2,000RPM
VIBRATIONS @ CONTROLS	N/A	N/A
VACUUM MOTOR	0.54hp / 0.4KW	
WATER LIFT - AIR FLOW	45 in / 1,143 mm	
BATTERIES	Lithium-ion batteries, 120AH	
RUN TIME PER CHARGE	3 Hours	
VOLTAGE DC	24V	
DECIBEL RATE AT OPERATOR'S EAR, INDOORS	68dB(A)	
GRADE LEVEL, MAX	5% (3°)	

RECOVERY TANK GROUP

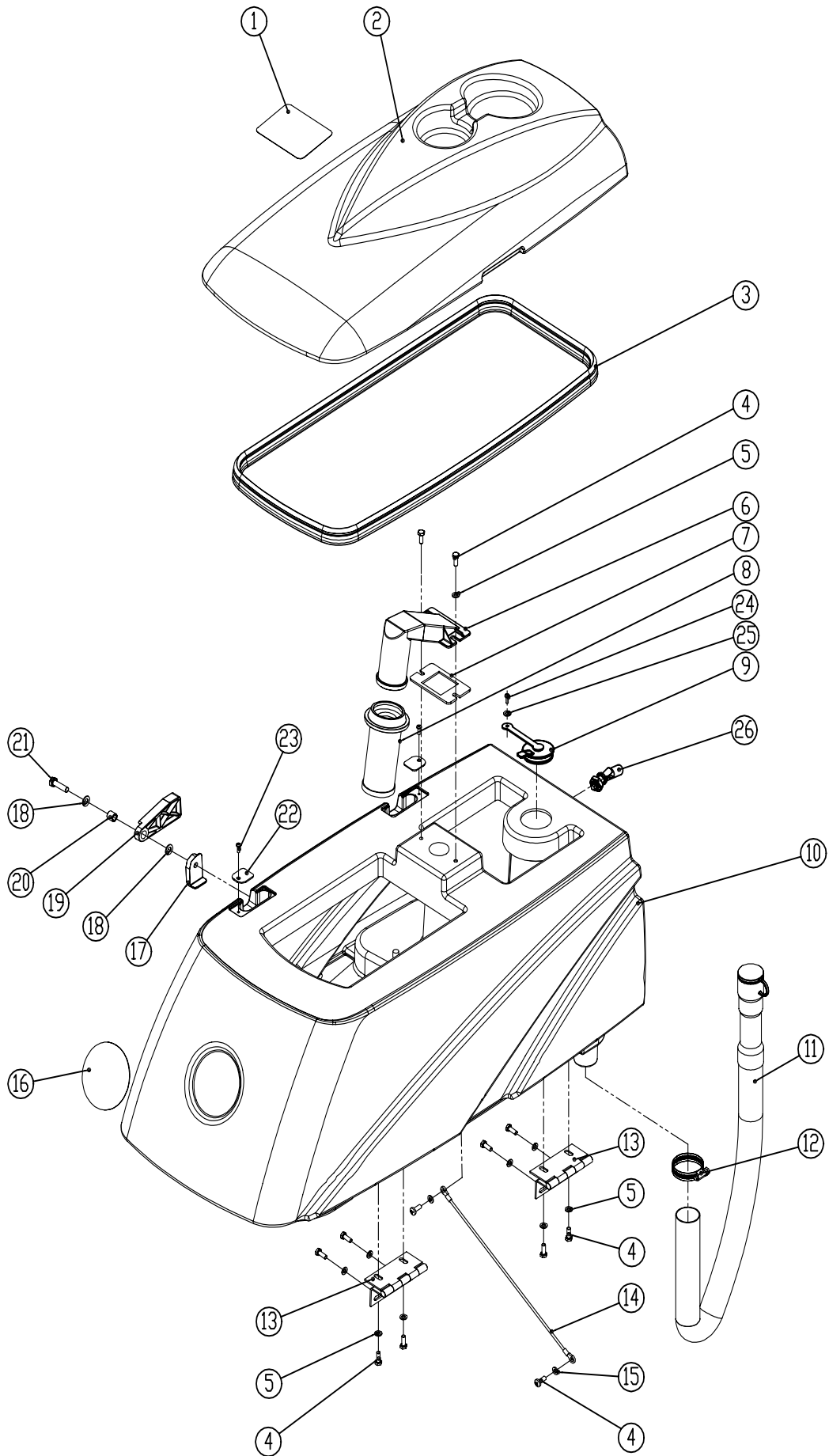

PARTS LIST

RECOVERY TANK GROUP

DIA NO.	PART NUMBER	DESCRIPTION	SERIAL NUMBER	NO REQ'D
1	8111022	WARNING LABEL		1
2	8131002	RECOVERY TANK COVER		1
3	8131005A	RECOVERY TANK COVER SEAL	60302100101~ 60303100101~	1
4	1021616	HEX BOLT M6 X 16		12
5	1421618	FLAT WASHER M6×φ18×1.6		10
6	8111014	FLOAT ADAPTER		1
7	8111001	GASKET		1
8	8111015	FLOAT, SHUT-OFF		1
9	8131003	CAP	60302100101~60302100996 60303100101~60303100257	1
	8131004	CAP	60302100997~ 60303100314~	
10	8131001A	RECOVERY TANK, UNSUITABLE FOR USE DETERGENT SYSTEM		1
11	8131030	DRAIN HOSE	60302100101~60302100978 60303100258~60303100257	1
	8131031	DRAIN HOSE	60302100979~ 60303100258~	
12	1962050	CLAMP		1
13	8111300	HINGE ASSEMBLY		2
14	8131020	CABLE		1
15	1421612	FLAT WASHER M6×φ12×1.6		2
16	4010316	ICE LOGO		1
17	8111008	BRACKET		1
18	1421816	FLAT WASHER M8×φ16×1.6		2
19	8111007	RECOVERY TANK SUPPORT		1
20	8115404	SLEEVE, P/M		1
21	1021830	HEX BOLT M8×30		1
22	8111016	PLATE		2
23	1221412	SCREW M4×12		2
24	1321110	SELF-TAPPING SCREW ST3.5 ×10		1
25	1421409	FLAT WASHER M4×φ9×0.8		1
26	8310238	WATER LEVEL SENSOR	60302100101~ 60303100101~	1

NOTES:

DIA NO.3 11:New part number from supplier change,New part number from supplier change, will also fit old machine.

DIA NO.9 :Two pieces change to one pieces,material is changed to rubber.

VACUUM FAN GROUP

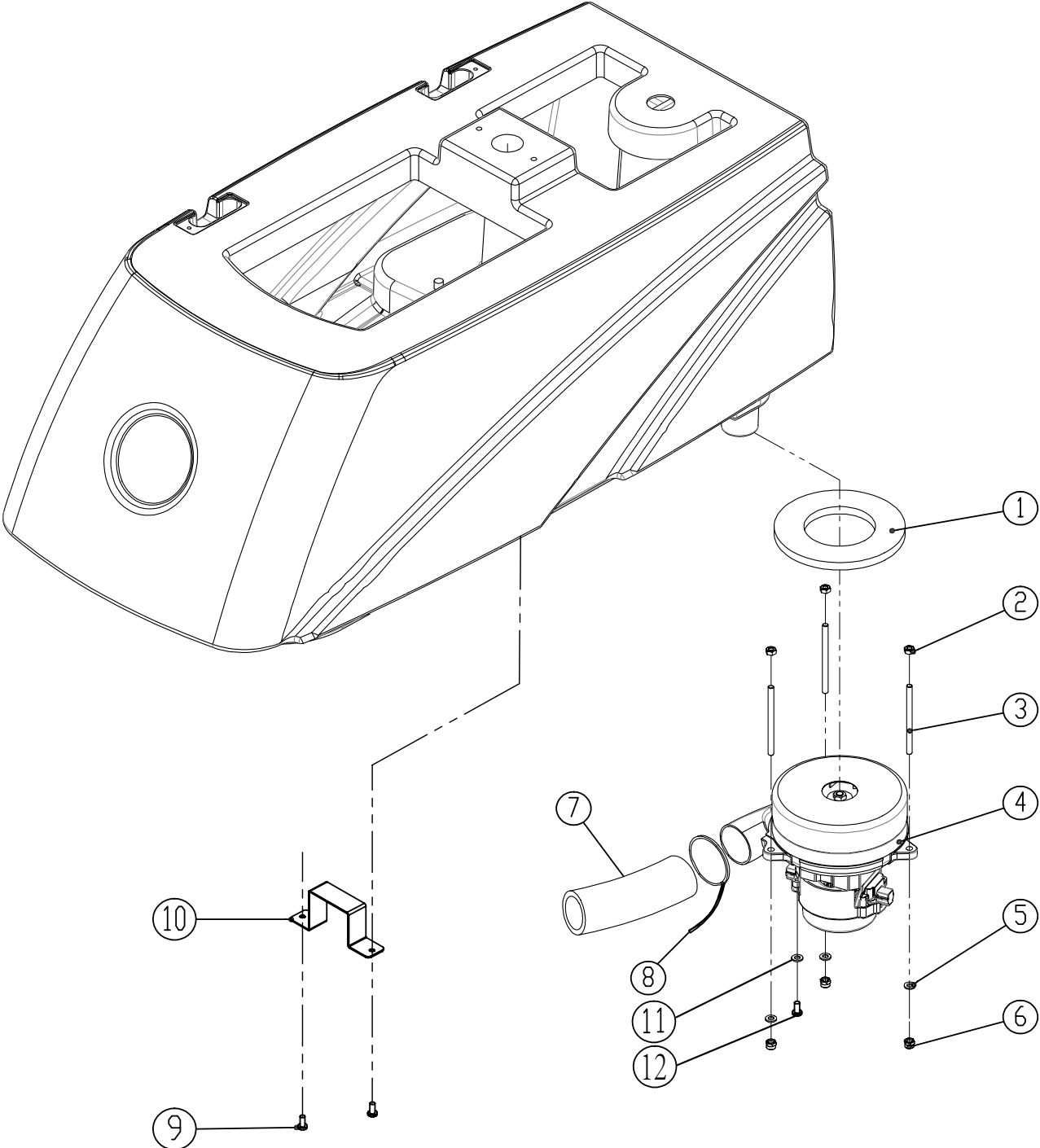

PARTS LIST

VACUUM FAN GROUP

DIA NO.	PART NUMBER	DESCRIPTION	SERIAL NUMBER	NO REQ'D
1	8112005	GASKET, VACUUM MOTOR		1
2	1121605	HEX NUT M6		3
3	8112006	STUD M6×92		3
4	8116500	AMETEK VACUUM MOTOR , KIT, 24VDC	60302100802~ 60303100233~	1
	8112008	CARBON BRUSH, 24VDC VACUUM MOTOR		2
5	1421612	FLAT WASHER M6×φ12×1.6		7
6	1123608	LOCK NUT M6		3
7	8132007	MUFFLER, VACUUM MOTOR		1
8	1914300	TIE, NYLON, 5X300		2
9	1221512	SCREW M5×12		2
10	8133012	BRACKET		1
11	1422513	LOCK WASHER M5		1
12	1321310	TAPPING SCREW ST5X10		1

NOTES:

DIA NO 11~12: Design optimization of new parts.

SOLUTION TANK GROUP

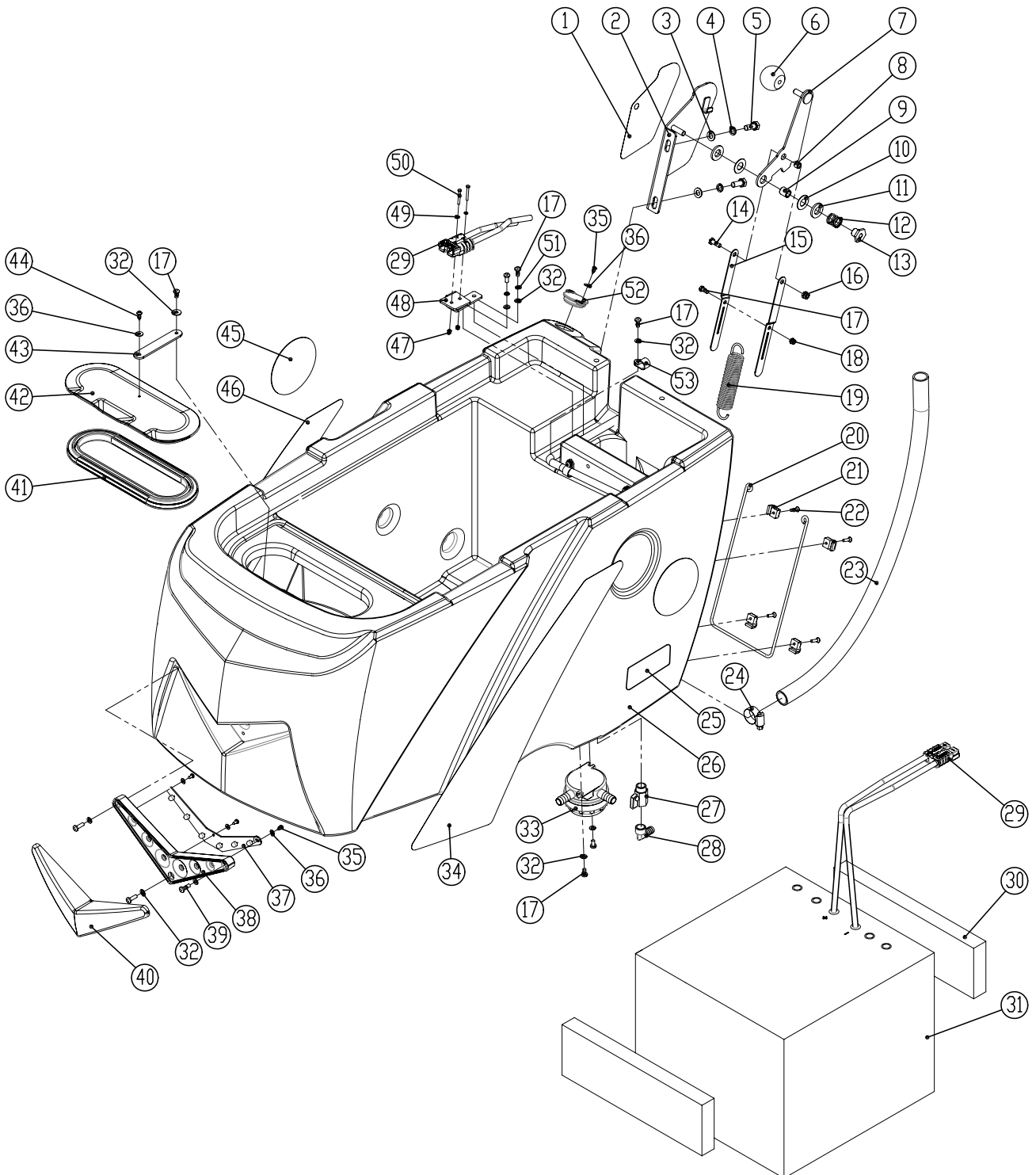

PARTS LIST

SOLUTION TANK GROUP

DIA NO.	PART NUMBER	DESCRIPTION	SERIAL NUMBER	NO REQ'D
1	8113115	DOWN PRESSURE LABEL		1
2	8113101	DOWN PRESSURE LEVER BRACKET		1
3	1421816	FLAT WASHER M8× ϕ 16×1.6		2
4	1422821	LOCK WASHER M8		2
5	1021820	HEX BOLT M8×20		2
6	8113104	BALL KNOB		1
7	8113106	DOWN PRESSURE LEVER		1
8	8113112	BUSHING		1
9	8113110	SLEEVE, P/M		1
10	8113111	N Y L O N F L A T W A S H E R ϕ 12.9× ϕ 25.4×0.8		2
11	8113109	THRUST BEARING		2
12	8113114	SPRING		1
13	8113107	RETAINER, SPRING		1
14	8113103	BOLT M6×18		1
15	8113108	LINK, SPRING		2
	8133108	LINK, SPRING, ORBITAL HEAD MODEL		2
16	1123608	LOCK NUT M6		1
17	1221512	SCREW M5×12		15
18	1123507	LOCK NUT M5		1
19	8133113	SPRING		1
20	8133501	CARGO NET		1
21	8133502	CLAMP		4
22	1221412	SCREW M4X12		4
23	8133008	CLEAN TUBING		1
24	1962025	CLAMP 16-25mm		1
25	8130099	i-SYNERGY DECAL		2
26	8133001	SOLUTION TANK, UNSUITABLE FOR USE DETERGENT SYSTEM		1
	8138001	SOLUTION TANK, SUITABLE FOR USE DETERGENT SYSTEM		1
27	8119005	BALL VALVE, G1/2		1
28	8119007	ELBOW G1/2		1
29	8134750	CONNECTOR, GRID, BLUE		2
30	8113013	SPACER, BATTERY		2

SOLUTION TANK GROUP

DIA NO.	PART NUMBER	DESCRIPTION	SERIAL NUMBER	NO REQ'D
31	N240130-G	LITHIUMS-ION BATTERIES, 120AH 3G	~60302100696 ~60303100258	1
	N241130-G	LITHIUMS-ION BATTERIES, 120AH 4G	60302100696~ 60303100258~	1
32	1421510	FLAT WASHER M5×φ10×1		17
33	8119200	FILTER ASSEMBLY		1
34	8133025	LABEL, LEFT SIDE		1
35	1321110	SELF-TAPPING SCREW ST3.5 ×10		4
36	1421409	FLAT WASHER M4×φ9×0.8		5
37	8133610	LED LIGHT, KIT		1
38	8133601	LED LIGHT MNTG BASE		1
39	1221520	SCREW M5X20		3
40	8133602	LED LIGHT COVER		1
41	8113030	SEAL		1
42	8113002	COVER		1
43	8113007	STRAP		1
44	1321213	SELF-TAPPING SCREW ST4.2X13		1
45	4010316	ICE Logo		2
46	8133026	LABEL, RIGHT SIDE		1
47	1123305	LOCK NUT M3		2
48	8113010	BRACKET, CONNECTOR MTG		1
49	1434300	LOCK WASHER, TOOTH, M3		2
50	1211325	SCREW M3×25		2
51	1422513	LOCK WASHER M5		2
52	8133002	CAP, SOLUTION FILL		1
53	8113009	NYLON, CLAMP		9

NOTES:

DIA NO 31: The communication module in the battery has been upgraded from 3G to 4G.

PARTS LIST

CONTROL CONSOLE GROUP (i20NBTL+/i24BTL+)

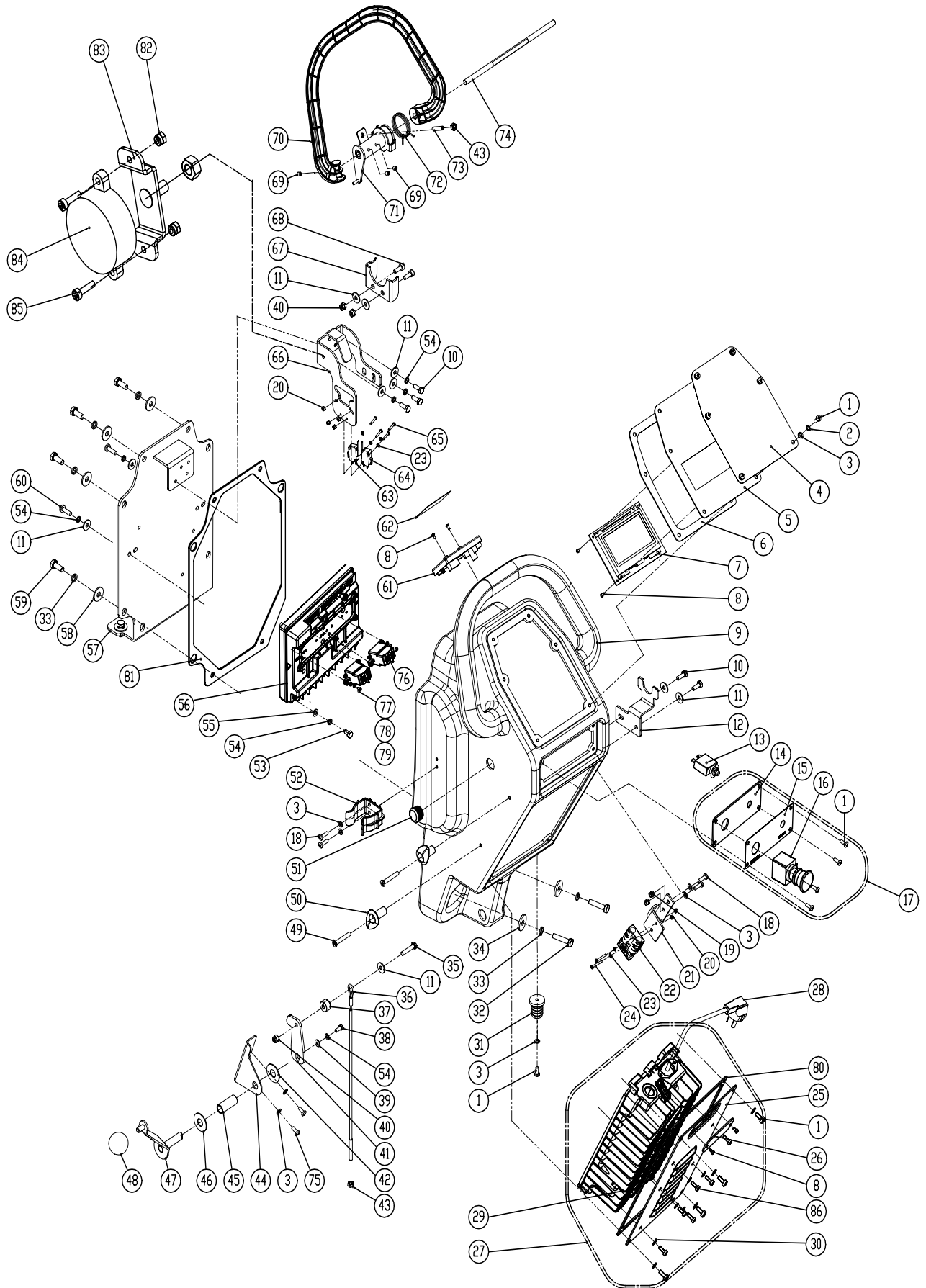

CONTROL CONSOLE GROUP (i20NBTL+/i24BTL+)

DIA NO.	PART NUMBER	DESCRIPTION	SERIAL NUMBER	NO REQ'D
1	1221512	SCREW M5×12		19
2	1422513	LOCK WASHER M5		6
3	1421510	FLAT WASHER M5× ϕ 10×1.0		13
4	8144760	CONTROL PANEL DECAL, i20NBTL+		1
	8144761	CONTROL PANEL DECAL, i24BTL+		1
5	8174505	CONTROL PANEL, i20NBL+		1
6	8134015	GASKET		1
7	8134922	5 "ANDROID LCD SCREEN	60302100696~ 60303100258~	1
8	1221306	SCREW M3×6		7
9	8134005	CONTROL HOUSING	60302100703~ 60303100302~	1
10	1021616	HEX BOLT M6 X 16		5
11	1421618	PLAIN WASHER M6× ϕ 18×1.6,SS		10
12	8114008	BRACKET, SQGE STORAGE		1
13	8310740	CIRCUIT BREAKER, 5A		1
14	8134007	BASE, EMERGENCY STOP SWITCH		1
15	8144027	LABEL, EMERGENCY STOP SWITCH		1
16	8310707	BUTTON,EMERGENCY STOP		1
17	8124730	EMERGENCY STOP SWITCH KIT		1
18	1221515	PH SCREW M5×15		4
19	1123507	LOCK NUT M5		6
20	1123305	LOCK NUT M3		6
21	8113010	BRACKET, CONNECTOR MTG		1
22	8134750	CONNECTOR, GRID, BLUE		1
23	1434300	LOCK WASHER, TOOTH, M3		6
24	1211325	SCREW M3×25		2
25	8134060	PLATE, ON BOARD BATTERY CHARGER	60302100101~60302100433 60303100101~60303100181	1
	8134066	PLATE, ON BOARD BATTERY CHARGER	60302100459~ 60303100233~	
26	8134061	CLEAR COVER		1
27	7000819	LITHIUM BATTERY CHARGER ASSEMBLY (AFTER SALES CHARGER KIT)	60302100101~60302100543 60303100101~60303100232	1
	7000805	LITHIUM BATTERY CHARGER ASSEMBLY (AFTER SALES CHARGER KIT)	60302100459~ 60303100233~	
	8134610A	ON BOARD BATTERY CHARGER, 110VAC	60302100101~60302100492 60303100101~60303100181	
28	8112030A	BATTERY CHARGER POWER CORD, KIT	60302100101~60302100543 60303100101~60303100232	1
	8112030	BATTERY CHARGER POWER CORD, KIT, US	60302100459~ 60303100233~	
29	8134600-US	ON BOARD BATTERY CHARGER, KIT	60302100101~60302100492 60303100101~60303100181	1
30	1421409	FLAT WASHER, M4× ϕ 9×0.8		6
31	8114005	CONNECTOR		1
32	1021840	HEX BOLT M8×40		2
33	1422821	LOCK WASHER M8		12
34	1421828	FLAT WASHER M8× ϕ 28×3		2
35	1021630	HEX HEAD BOLT M6×30,SS		1

PARTS LIST

CONTROL CONSOLE GROUP (i20NBTL+/i24BTL+)

DIA NO.	PART NUMBER	DESCRIPTION	SERIAL NUMBER	NO REQ'D
36	8134082	CABLE, SQGE LIFT		1
37	8014101	LIFTING ROPE SPACER		1
38	1021610	HEX HEAD BOLT M6×10,SS		1
39	1421616	FLAT WASHER M6×φ16×1.0		1
40	1123608	LOCK NUT M6		3
41	8014012	BAFFLE		1
42	8113111	NYLON FLAT WASHER φ12.9×φ25.4×0.8		1
43	1121605	HEX NUT M6		3
44	8134501	BRACKET		1
45	8134081	SLEEVEE		1
46	1421132	FLAT WASHER M12×φ32×1.5		1
47	8134080	SQUEEGEE LIFTING HANDLE	60302100802~ 60303100233~	1
48	8113104	BALL KNOB M8		1
49	1222641	SUNK HEAD SCREW M6 X 40		2
50	8210112	HOOK, POWER CORD		2
51	7000318	PLUG(ROUNG PLUG)		1
52	6210111	CLAMP, DRAIN HOSE		1
53	1023612	HEX BOLT M6 X 12, COPPER		8
54	1422616	LOCK WASHER, M6		13
55	1423612	FLAT WASHER M6× φ12×1, COPPER		8
56	8144890	MAIN CONTROLLER, i20NBT+		1
57	8134070	REAR PLATE, CONTROL CONSOLE		1
58	1421824	FLAT WASHER M8× φ24×2		10
59	1021820	HEX BOLT M8×20		10
60	1221620	PH SCREW M6×20		2
61	8134775	RFID BOARD	60302100459~ 60303100206~	1
62	8134036	LABEL, i-SYNERGY™ CARD SCANNING		1
63	8114712	MICRO SWITCH		1
64	8124743	MICRO SWITCH		1
65	1021320	SCREW M3 X 20		4
66	8134022	BRACKET,SWITCH		1
67	8114402	BRACKET, SPRING		1
68	1521616	SCREW M6X16, HEX SCOKET		2
69	1534608	SET SCREW M6 × 8		4
70	8134300	LEVER, BAIL		1
71	8114300	ACTUATOR		1
72	8114306	SPRING		1
73	1535630	SET SCREW M6 × 30		1
74	8114101	SHAFT		1
75	1021512	HEX HEAD BOLT M5×12,SS		2

CONTROL CONSOLE GROUP (i20NBTL+/i24BTL+)

DIA NO.	PART NUMBER	DESCRIPTION	SERIAL NUMBER	NO REQ'D
76	8313420	RELAY,24VDC 120A		2
77	1421409	FLAT WASHER, M4× ϕ 9×0.8		4
78	1422411	LOCK WASHER, M4		4
79	1221416	SCREW, HEX HEAD, M4×16		4
80	8134083	CONTROL BOX SEAL RING	60302100957~ 60303100258~	1
81	8134085	SEALING RING ON back OF CONTROL BOX	60302100997~ 60303100258~	1
82	1111302	NUT,M3		2
83	8134023	BRACKET,HORN	60302108817~ 60303100233~	1
84	8310708	HORN		1
85	1211320	SCREW,M3X20		2
86	1221412	SCREW M4×12		6

NOTES:

DIA NO.7 : ADD SPANISH LANGUAGE ON THE UI.

DIA NO 25、 27、 28、 29、 30、 86: Charger supplier change, involving code change;The code 7000805 is used with 8112030, and the code 7000819 is used with 8112030A.

DIA NO 61: Design improvement,the new design can fit old machine.

DIA NO 62: The customer requested special stickers.

DIA NO 80、 81: Design optimization of new parts.

DIA NO 82~85 : Add bracket to easy service the Horn.

PARTS LIST

FRAME & TRANSAXLE GROUP (i20NBTL+/i24BTL+)

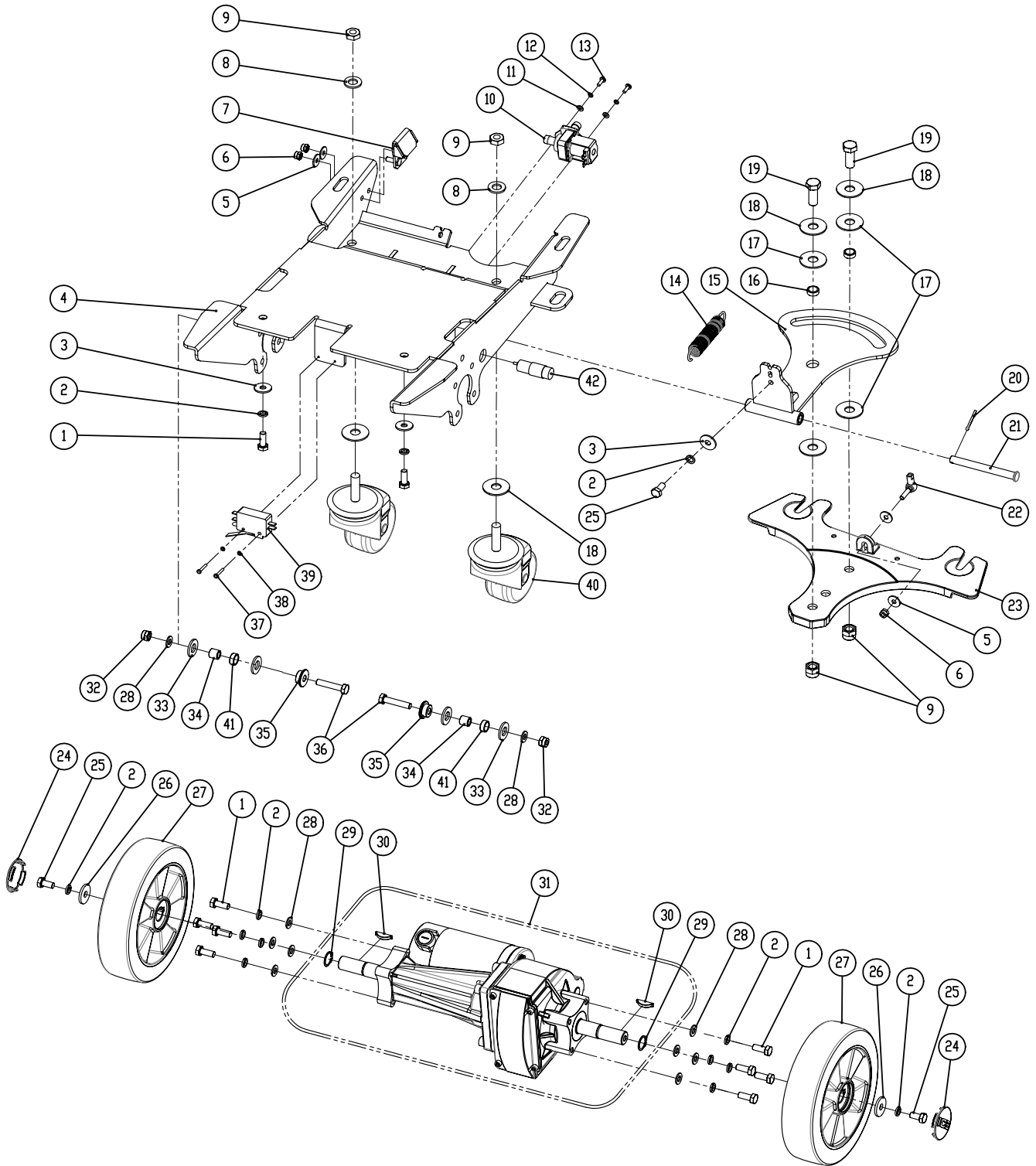

FRAME & TRANSAXLE GROUP (i20NBTL+/i24BTL+)

DIA NO.	PART NUMBER	DESCRIPTION	SERIAL NUMBER	NO REQ'D
1	1021820	HEX BOLT M8×20		12
2	1422821	LOCK WASHER M8		15
3	1421824	FLAT WASHER M8×φ24×2		5
4	8145100	MAIN FRAME		1
5	1421618	FLAT WASHER M6×φ18×1.6		4
6	1123608	LOCK NUT M6		3
7	8115300	BRACKET, PEDAL LOCKING		1
8	1421124	FLAT WASHER M12×φ24×2.5		4
9	1123115	LOCK NUT M12		4
10	8119003	SOLENOID VALVE, 24VDC		1
11	1421409	FLAT WASHER M4×φ9×0.8		2
12	1422411	LOCK WASHER M4		2
13	1221412	SCREW M4×12		4
14	8115004	SPIRNG		1
15	8135010	BRACKET, SQGE LIFT	60302100703~ 60303100302~	1
16	8115005	AXLE SLEEVE		2
17	8135001	PLASTIC THRUST WASHER M12×φ 30×1.5		4
18	1421132	FLAT WASHER M12×φ32×1.5		4
19	1021230	HEX BOLT M12 × 30		2
20	1645324	COTTER 3.2 × 24		1
21	8115003	PIN		1
22	8114511	BALL JOINT M6		1
23	8115001	BRACKET, SQGE MNTG		1
24	8115203	COVER, WHEEL		2
25	1021816	HEX BOLT M8×16		3
26	1421828	FLAT WASHER M8×φ28×3		2
27	8125200	WHEEL, 8 INCH		2
	8225200	AIR FILLED WHEEL, 8 INCH, KIT (OPTION)		2
	8225210	FOAM FILLED WHEEL, 8INCH, KIT (OPTION)		2
28	1421816	FLAT WASHER M8×φ16×1.6		10
29	1436019	RETAINING RING 19		2
30	8125403	WOODRUFF KEY		2
	8125409	FLAT KEY 4.75*5*25MM, FOR 8125408		2
31	8125410	TRANSAXLE, KIT	60302100101~60302100883 60303100101~60303100257 60302101024~ 60303100259~	1
	8116111	CARBON BRUSH, DRIVE MOTOR		2
	8125408	TRANSAXLE, KIT	60302100884~60302101023 60303100258	1
	8116111	CARBON BRUSH, DRIVE MOTOR		2

PARTS LIST

FRAME & TRANSAXLE GROUP (i20NBTL+/i24BTL+)

DIA NO.	PART NUMBER	DESCRIPTION	SERIAL NUMBER	NO REQ'D
32	1123810	LOCK NUT M8		10
33	8117007	NYLON WASHER $\phi 12.9 \times \phi 24 \times 2.5$		4
34	8115404	BEARING, JOURNAL		2
35	8145001	BUSHING		2
36	1021840	HEX BOLT M8 $\times 40$		2
37	1211325	SCREW M3 $\times 25$		2
38	1434300	LOCK WASHER, TOOTH, M3		2
39	8014071	MICRO SWITCH 20A		1
40	8115500	CASTER, SWIVEL, 80MM		2
41	8115405	SLEEVE, P/M		2
42	8134709A	PROXIMITY SENSOR, KIT		1

NOTES:

DIA NO 15: Structure optimization.

DIA NO 31: Supplier change, the new transaxle 8125408 can fit the old machine.

PARTS LIST

SCRUB HEAD GROUP (i20NBTL+)

DIA NO.	PART NUMBER	DESCRIPTION	SERIAL NUMBER	NO REQ'D
1	8116800	BRUSH MOTOR, 24VDC 650W 215RPM KIT		1
	8116601	BRUSH MOTOR CARBON BRUSH		2
	8116200	BRUSH MOTOR, 24VDC 550W 210RPM KIT		1
	8116007	BRUSH MOTOR CARBON BRUSH		2
2	1656433	KEY		1
3	1221412	SCREW M4×12		1
4	1422513	LOCK WASHER M5		3
5	1421518	FLAT WASHER M5× ϕ 18×2		1
6	8116100	WATER SUPPLY TUBE		1
7	8116006	SCRUB HEAD HOUSING		1
8	8116020	BUMPER, SCRUB HEAD		1
9	8116001	SPACER		2
10	8116008	HUB, DRIVE, 3 LUG		1
11	1221512	SCREW M5×12		2
12	1421510	FLAT WASHER M5× ϕ 10×1		2
13	8116002	BRUSH CLAMP PLATE		1
14	8116003	SPRING CLIP		1
15	8116010	FLAT WASHER ϕ 8.5× ϕ 25.4×4.5		1
16	1422821	LOCK WASHER M8		2
17	1023815	HEX BOLT 5/16-18 ×1.5" UNC		1
18	1222635	SCREW, M6X35		6
19	8116030	STUD		6
20	9040019	19" PAD DRIVER		1
	9040019K	19" PAD DRIVER (OPTION)		1
21	9000001	BIG MOUTH		1
	9000003	CENTER-LOK 3 (OPTION)		1
22	1321325	SELF-TAPPING SCREW, ST4.8X25		3
23	8116040	SPACER		3
24	9050020	20" BRUSH, 0.7mm PP BRISTLE (OPTION)		1
	9050020E	20" BRUSH, 0.5mm PP BRISTLE (OPTION)		1
25	1023010	HEX BOLT 3/8-16 ×1" UNC		4
26	1422026	LOCK WASHER M10		4
27	1421030	FLAT WASHER M10× ϕ 30×2.5		4
28	8116202	PIN		1
29	8116205	SCREW M14 × 20		1
30	8111023	WARNING LABEL		1
31	1121913	HEX NUT M14		1
32	8116204	SRPING		1
33	8116210	KNOB M6		1
34	8116009	PROTECTIVE WHEEL		1
35	8115404	SLEEVE, P/M		1
36	1421824	FLAT WASHER M8× ϕ 24×2.0		1
37	1021825	HEX BOLT M8×25		1

NOTES: DIA NO 1: New part number from supplier change, will also fit old machine.

SCRUB HEAD GROUP (i24BTL+)

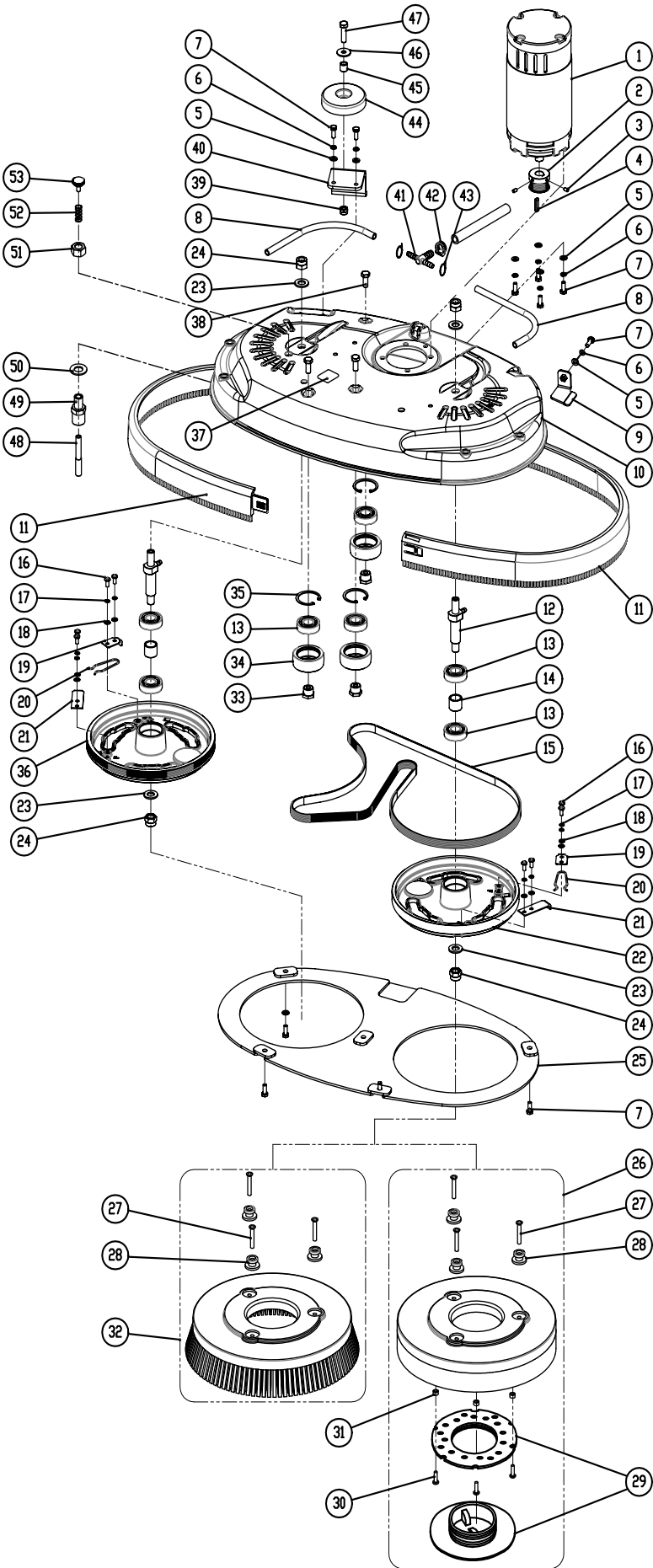

PARTS LIST

SCRUB HEAD GROUP (i24BTL+)

DIA NO.	PART NUMBER	DESCRIPTION	SERIAL NUMBER	NO REQ'D
1	8126200	BRUSH MOTOR, 24VDC 680W 2000RPM, KIT		1
	8126070	CARBON BRUSH, BRUSH MOTOR		2
2	8126006	SHEAVE, SS		1
3	1534508	SCREW, SET, M5X8		2
4	1655025	KEY, 5X5X25		1
5	1421612	FLAT WASHER M6× ϕ 12×1.6		7
6	1422616	LOCK WASHER, M6		7
7	1021616	HEX BOLT M6×16		12
8	8119301	TUBING, ID=6mm, L=250mm		2
9	8126007	BRACKET, GUIDE, BELT		1
10	8126002	SCRUB HEAD HOUSING		1
11	8126050	BUMPER, SCRUB HEAD		2
12	8126040	SHAFT, PULLY		2
13	1612203	BEARING, 6203RS		7
14	8126008	BUSHING		2
15	8126005	BELT, 6PJ1598		1
16	1221512	SCREW M5×12		8
17	1422513	LOCK WASHER M5		8
18	1421510	FLAT WASHER M5× ϕ 10×1		8
19	8116002	BRUSH CLAMP PLATE		2
20	8116003	SPRING CLIP		2
21	8126009	PLATE, CLAMP, BRUSH		2
22	8126004	HUB, DRIVER, 3LUG, PULLY		1
23	1421124	FLAT WASHER M12× ϕ 24×2.5		4
24	1123115	LOCK NUT M12		4
25	8126020	BRACKET, GUARD, SPLASH		1
26	9040011U	11" PAD DRIVER		2
	9050012U	11" PAD DRIVER (OPTION)		2
27	1222635	SCREW, M6X35		12
28	8116030	STUD		12
29	9000001	BIG MOUTH		2
	9000003	CENTER-LOK 3 (OPTION)		2
30	1321325	SELF-TAPPING SCREW, ST4.8X25		6
31	8116040	SPACER		6
32	9050012	12" BRUSH (OPTION)		2
33	8126032	SPACER, IDLER		3
34	8126031	PULLEY, IDLER		3

SCRUB HEAD GROUP (i24BTL+)

DIA NO.	PART NUMBER	DESCRIPTION	SERIAL NUMBER	NO REQ'D
35	1437040	RING, RETAINING, 40		3
36	8126003	HUB, DRIVE, 3LUG, 6GRV		1
37	8111023	WARNING LABEL		1
38	1021820	HEX BOLT M8×20		3
39	1123810	LOCK NUT M8		1
40	8126012	BRACKET, WALL-ROLLER		1
41	8119004	FITTING, PLASTIC, TEE		1
42	1962016	CLAMP, 10-16mm		1
43	1914300	TIE, NYLON, 5X300		2
44	8116009	PROTECTIVE WHEEL		1
45	8115404	SLEEVE, P/M		1
46	1421824	FLAT WASHER M8× ϕ 24×2.0		1
47	1021825	HEX BOLT M8×25		1
48	8126202	PIN		1
49	8126205	GUIDE, M14X20		1
50	1421428	FLAT WASHER M14× ϕ 28×2.0		1
51	1121913	NUT M14		1
52	8116204	SPRING		1
53	8116210	KNOB M6		1

PARTS LIST

SCRUB HEAD LIFT GROUP (i20NBL+ / i20NBTL+)

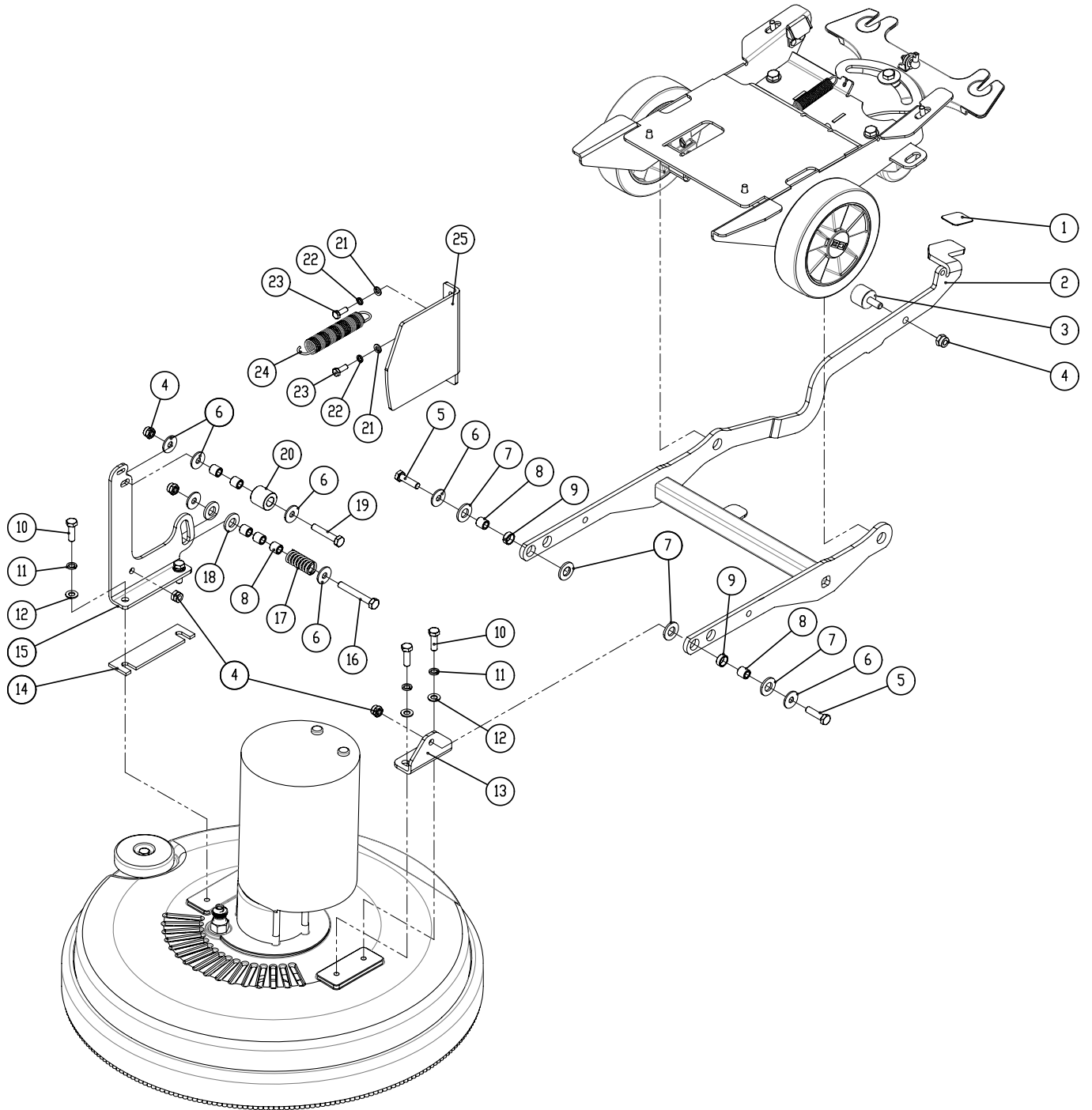

SCRUB HEAD LIFT GROUP (i20NBTL+)

DIA NO.	PART NUMBER	DESCRIPTION	SERIAL NUMBER	NO REQ'D
1	8137006	NON-SLIP MAT		1
2	8137100	BRACKET, SCRUB HEAD LIFT		1
3	8133151	BUMPER		1
4	1123810	LOCK NUT M8		5
5	1021830	HEX BOLT M8×30		2
6	1421824	FLAT WASHER M8× ϕ 24×2		6
7	8117007	NYLON WASHER ϕ 12.9× ϕ 24×2.5		4
8	8115404	BEARING, JOURNAL		7
9	8115405	SLEEVE, P/M		2
10	1021825	HEX BOLT M8×25		4
11	1422821	LOCK WASHER M8		4
12	1421816	FLAT WASHER M8× ϕ 16×1.6		4
13	8117002	LEFT BRACKET		1
14	8117005	SPACER(I20NB)		1
15	8117003	RIGHT BRACKET		1
16	1022860	HEX BOLT M8 × 60		1
17	8117008	SPRING		1
18	8113109	BEARING, THRUST		2
19	1022845	HEX BOLT M8 × 45		1
20	8117004	ROLLER		1
21	1421612	FLAT WASHER M6× ϕ 12×1.6		2
22	1422616	LOCK WASHER M6		2
23	1021616	HEX BOLT M6 × 16		2
24	8117009	SPRING		1
25	8117001	BRACKET, GUIDE		1

SCRUB HEAD LIFT GROUP (i24BTL+)

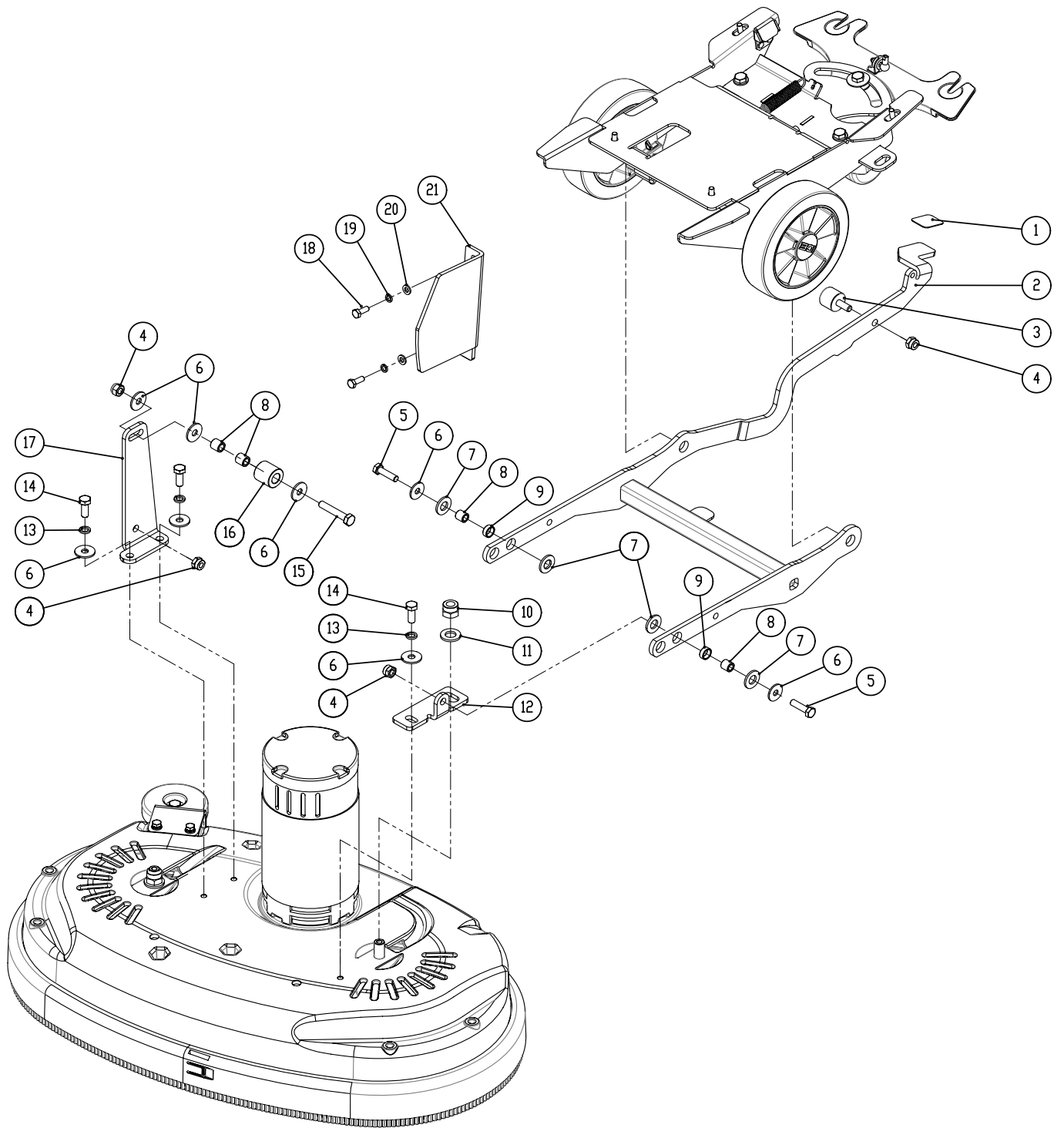

SCRUB HEAD LIFT GROUP (i24BTL+)

DIA NO.	PART NUMBER	DESCRIPTION	SERIAL NUMBER	NO REQ'D
1	8137006	NON-SLIP MAT		1
2	8137100	BRACKET, SCRUB HEAD LIFT		1
3	8133151	BUMPER		1
4	1123810	LOCK NUT M8		5
5	1021830	HEX BOLT M8×30		2
6	1421824	FLAT WASHER M8× ϕ 24×2		8
7	8117007	NYLON WASHER ϕ 12.9× ϕ 24×2.5		4
8	8115404	BEARING, JOURNAL		4
9	8115405	SLEEVE, P/M		2
10	1123115	LOCK NUT M12		1
11	1421124	FLAT WASHER M12× ϕ 24×2.5		1
12	8126011	LEFT BRACKET		1
13	1422821	LOCK WASHER M8		3
14	1021820	HEX BOLT M8 × 20		3
15	1022845	HEX BOLT M8 × 45		1
16	8117004	ROLLER		1
17	8126010	RIGHT BRACKET		1
18	1021616	HEX BOLT M6 × 16		2
19	1422616	LOCK WASHER M6		2
20	1421612	FLAT WASHER M6× ϕ 12×1.6		2
21	8137001	BRACKET, GUIDE		1

SQUEEGEE GROUP

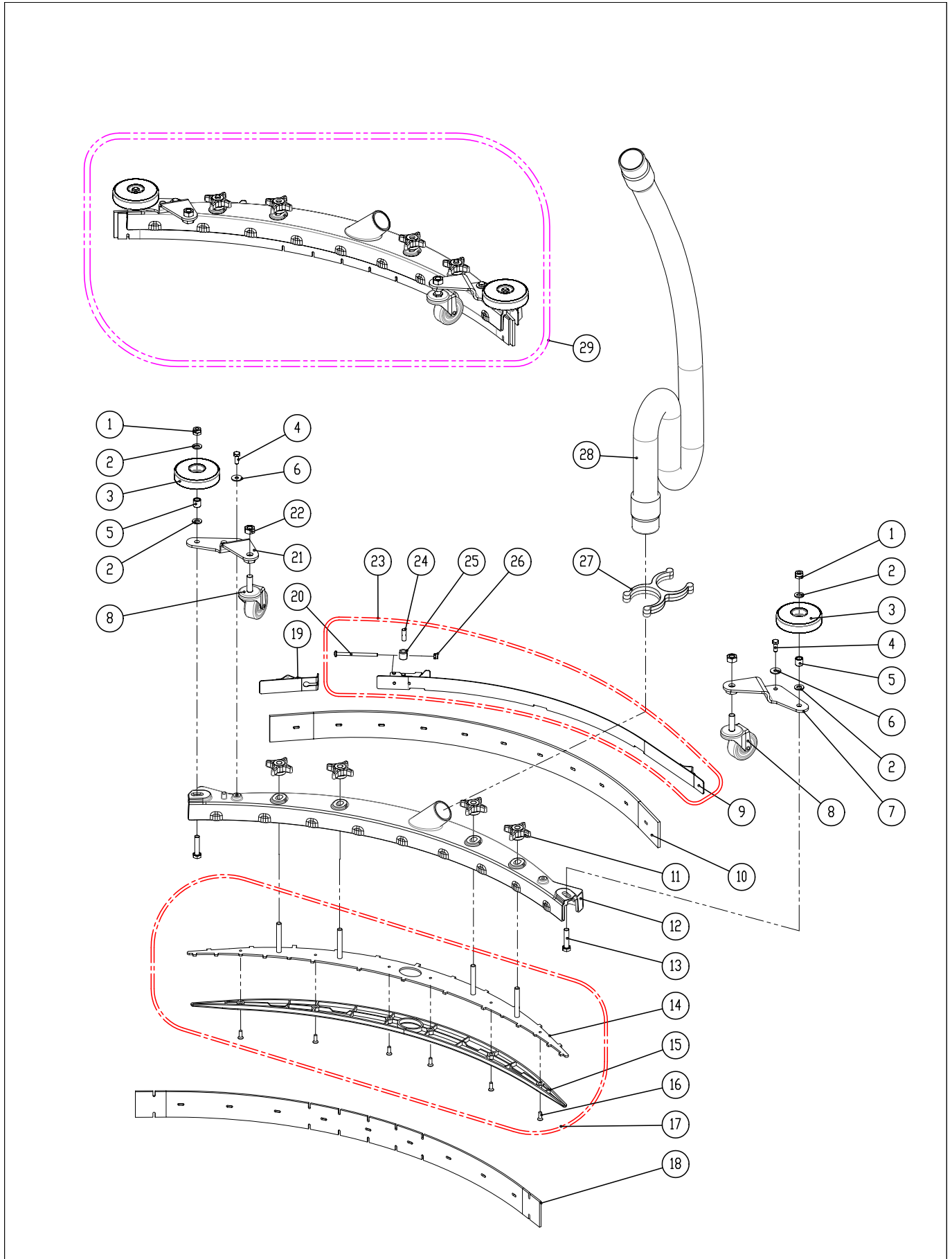

SQUEEGEE GROUP

DIA NO.	PART NUMBER	DESCRIPTION	SERIAL NUMBER	NO REQ'D
1	1123810	LOCK NUT M8		2
2	1421824	FLAT WASHER M8× ϕ 24×2.0		4
3	8116009	PROTECTIVE WHEEL		2
4	1021616	HEX BOLT M6×16		2
5	8115404	BEARING, JOURNAL		2
6	1421612	FLAT WASHER M6× ϕ 12×1.6		2
7	8118300	LEFT BRACKET		1
8	8118401	CASTER, 2 INCH		2
9	8118600	CLAMP ASSEMBLY, SQUEEGEE		1
10	8118022	SQUEEGEE BLADE, REAR, LINATEX		1
	8118002	SQUEEGEE BLADE, REAR, PU (OPTION)		1
11	8118003	STAR KNOB M8		4
12	8118004	SQUEEGEE HOUSING		1
13	1021835	HEX BOLT M8×35		2
14	8118009	S T A I N L E S S S T E E L L RETAINER,SQUEEGEE		1
15	8118008	PLASTIC SPACER		1
16	1222515	COUNTERSUNK FLAT HEAD SCREW M5×15		6
17	8118010	RETAINER KIT		1
18	8118021	SQUEEGEE BLADE, FRONT, LINATEX		1
	8118001	SQUEEGEE BLADE, FRONT, PU (OPTION)		1
19	8118610	SHORT CLAMP ASSEMBLY		1
20	1221575	SCREW M5×75		1
21	8118200	RIGHT BRACKET		1
22	1121008	HEX NUT M10		2
23	8118600A	CLAMP ASSEMBLY		1
24	8118624	SHAFT		1
25	8118623	SPACER		1
26	1123507	LOCK NUT M5		1
27	8118109	HOLDER VACUUM HOSE		1
28	8118006	VACUUM HOSE		1
29	8118000	SQUEEGEE ASSEMBLY, LINATEX		1
	8118000-PU	SQUEEGEE ASSEMBLY, PU		1

SOLUTION GROUP

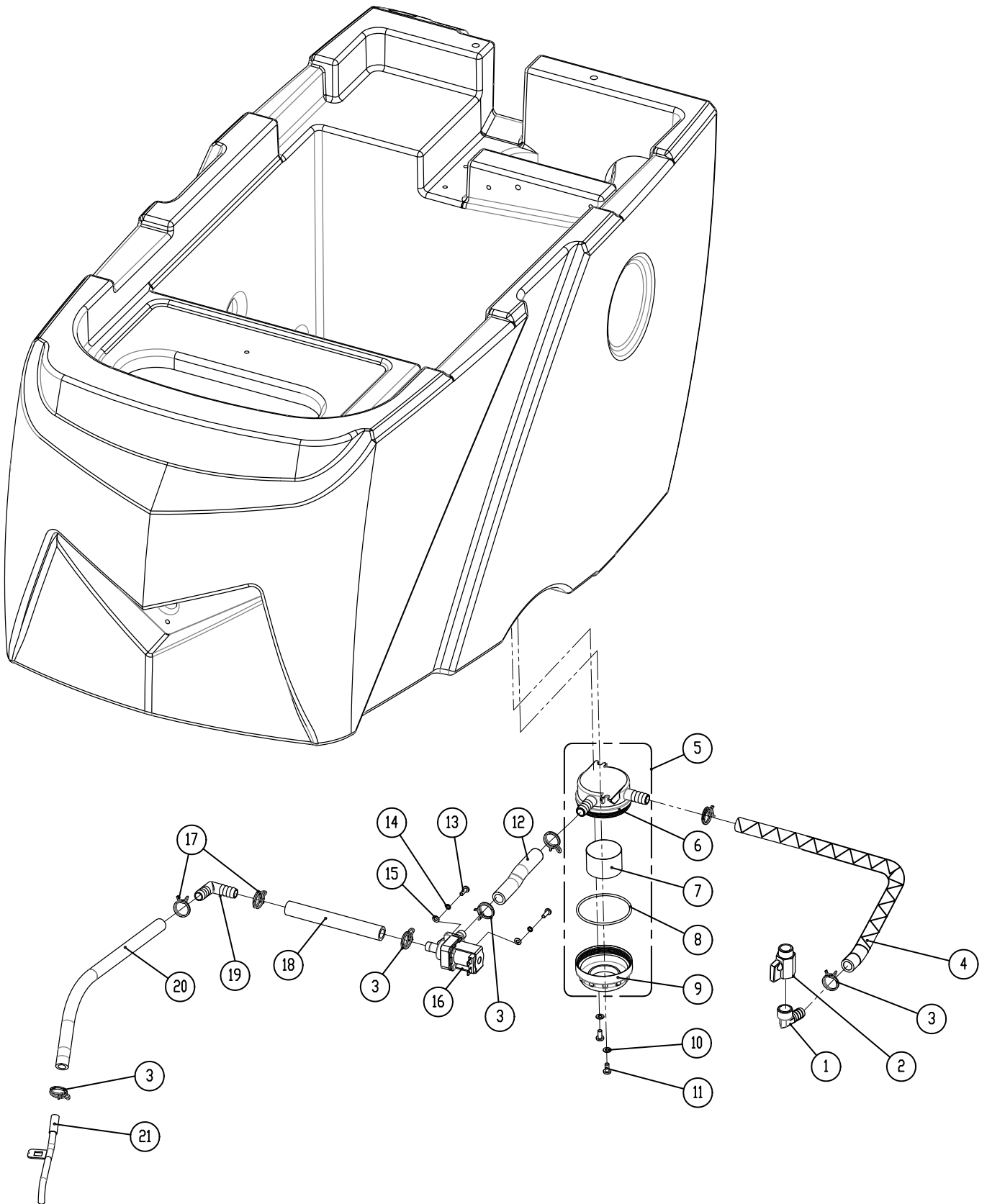

SOLUTION GROUP

DIA NO.	PART NUMBER	DESCRIPTION	SERIAL NUMBER	NO REQ'D
1	8119007	ELBOW G1/2		1
2	8119005	BALL VALVE, G1/2		1
3	1962016	CLAMP, 10-16mm		4
4	8119205	TUBING, WIRE REINFORCED, L=210MM		1
5	8119200	FILTER ASSEMBLY, 40 MESH		1
6	8119101	BASE, FILTER ASSEMBLY		1
7	8119104	SCREEN, FILTER, 40 MESH		1
8	1623660	O RING		1
9	8119102	CAP, FILTER ASSEMBLY		1
10	1421510	FLAT WASHER M5× ϕ 10×1		2
11	1221512	SCREW M5×12		2
12	8119202	TUBING ID=12MM L=100MM		1
13	1221412	SCREW M4×12		2
14	1422411	LOCK WASHER M4		2
15	1421409	FLAT WASHER M4× ϕ 9×0.8		2
16	8119003	SOLENOID VALVE, 24VDC		1
17	8119006	CLAMP		4
18	8119203	TUBING ID=12MM L=135MM		1
19	8119002	ELBOW, TUBING BARB		1
20	8119204	TUBING ID=10MM L=360MM		1
21	8116100	WATER SUPPLY TUBE		1

WEAR AND TEAR PARTS

DIA NO.	PART NUMBER	DESCRIPTION	SERIAL NUMBER	NO REQ'D
1	8115200	WHEEL, 8 INCH, i20NBL+		2
	1612607	BEARING, BALL, 6004, 8"WHEEL		4
	8125200	WHEEL, 8 INCH, i20NBTL+ / i24BTL+		2
2	8116009	PROTECTIVE WHEEL		3
3	8118021	SQUEEGEE BLADE, FRONT, LINATEX		1
4	8118022	SQUEEGEE BLADE, REAR, LINATEX		1
5	9050020	20" BRUSH ,i20NBL+/i20NBTL+		1
	9050020E	20" BRUSH ,i20NBL+i20/NBTL+ (OPTIONAL)		1
	9050012	12" BRUSH , i24BTL+		2
6	9040019	19" PAD HOLDER, i20NBL+/i20NBTL+		1
	9040019K	19" PAD HOLDER, i20NBL+/i20NBTL+ (OPTIONAL)		1
	9040011U	11" PAD HOLDER, i24BTL+		2
	9050012U	11" PAD HOLDER, i24BTL+(OPTIONAL)		2
7	8146116	ISOLATORS, M10×25, i20NBTL+-OB		4
	8146107	ISOLATORS, M10×25, i20NBTL+-OB		4

CERTIFICATE OF QUALIFIED

MODEL : _____

SERIAL NO.: _____

INSPECTOR: _____

DATE : _____

ICE Cobotics (GuangDdong) Company Limited

TEL : (+86) 769 8186 9000

FAX : (+86) 769 8186 3000