

ICE USA

A DIVISION OF ICE COBOTICS

www.ice4usa.com



Operator & Parts Manual

Rider Auto Scrubber



RS26+
RS32+

8320040
REV.03 (09-2022)

 **READ OPERATOR MANUAL CAREFULLY!**

IMPORTANT: To ensure full warranty protection, please fill out & return your warranty card.

Please fill out at time of installation for future reference.

Model No. _____

Serial No. _____

Machine Options _____

Sales Rep. _____

Sales Rep. Phone No. _____

Customer ID Number _____

Installation Date _____

HOW TO ORDER PARTS

Only use ICE Company supplied or equivalent parts. Parts and supplies may be ordered online, by phone, by fax or by mail.

1. Identify the machine model.
2. Identify the machine serial number from the data label.
3. Ensure the proper serial number is used from the parts list.
4. Identify the part number and quantity.
Do not order by page or reference numbers.
5. Provide your name, company name, customer ID number, billing and shipping address, phone number and purchase order number.



PROTECT THE ENVIRONMENT

Please dispose of packaging materials, old machine components such as batteries, hazardous fluids, including antifreeze and oil, in an environmentally safe way according to local waste disposal regulations.



Always remember to recycle.

ICE Company Limited

XiangShi Road LiaoBu DongGuan GuangDong China

Tel: 0769 - 81869000

Fax: 0769 - 81863000

Specifications and parts are subject to change without notice.

TABLE OF CONTENTS

SAFETY PRECAUTIONS.....4

MACHINE COMPONENTS.....5-6

MACHINE SETUP & INSTALLATION.....7

MACHINE OPERATION.....8

WHILE OPERATING MACHINE.....9

TANK DRAINING.....10

BATTERY CHARGING.....10

PREVENTATIVE MAINTENANCE.....10

FAULT CODE AND ELIMINATE.....11

TECHNICAL SPECIFICATIONS.....13

PARTS LIST.....14-41

WEAR AND TEAR PARTS.....42

WIRING DIAGRAM43

SAFETY PRECAUTIONS

This machine is intended for commercial use. It is designed exclusively to scrub hard floors in an indoor environment and is not constructed for any other use. Only use recommended accessories.

All operators shall read, understand and exercise the following safety precautions:

1. Do not operate machine:
 - Unless trained and authorized.
 - Unless you have read and understand the operators manual.
 - In flammable or explosive areas.
 - With brake disabled.
 - If not in proper operating condition.
2. Before starting machine:
 - Make sure all safety devices are in place and operate properly.
 - Check brakes and steering for proper operation.
3. When using machine:
 - Go slow on inclines and slippery surfaces.
 - Follow all safety guidelines.
 - Be very careful when using the machine in reverse.
 - Reduce speed when turning.
 - Report and fix any damage to machine prior to operating it.
 - Never allow children to play on or around.
4. Before leaving or servicing machine:
 - Stop on level surface.
 - Turn off machine.
5. When servicing machine:
 - Read operators manual thoroughly prior to operating or servicing this machine.
 - Use manufacturer supplied or approved replacement parts.
 - Secure machine with wheel blocks prior to jacking the machine up.
 - Use approved jack or hoist to safely elevate the machine.
 - Disconnect batteries prior to working on machine.
 - Avoid moving parts. Do not wear loose fitting clothing while servicing machine.

 **WARNING: Explosion or fire can result from hydrogen gas. Keep sparks and open flames away! Keep battery compartment open when charging.**

 **WARNING: Flammable materials can cause an explosion or fire. Do not use flammable materials in tanks.**

 **WARNING: Flammable materials or reactive metals can cause explosion or fire. Do not pick up.**

MACHINE COMPONENTS

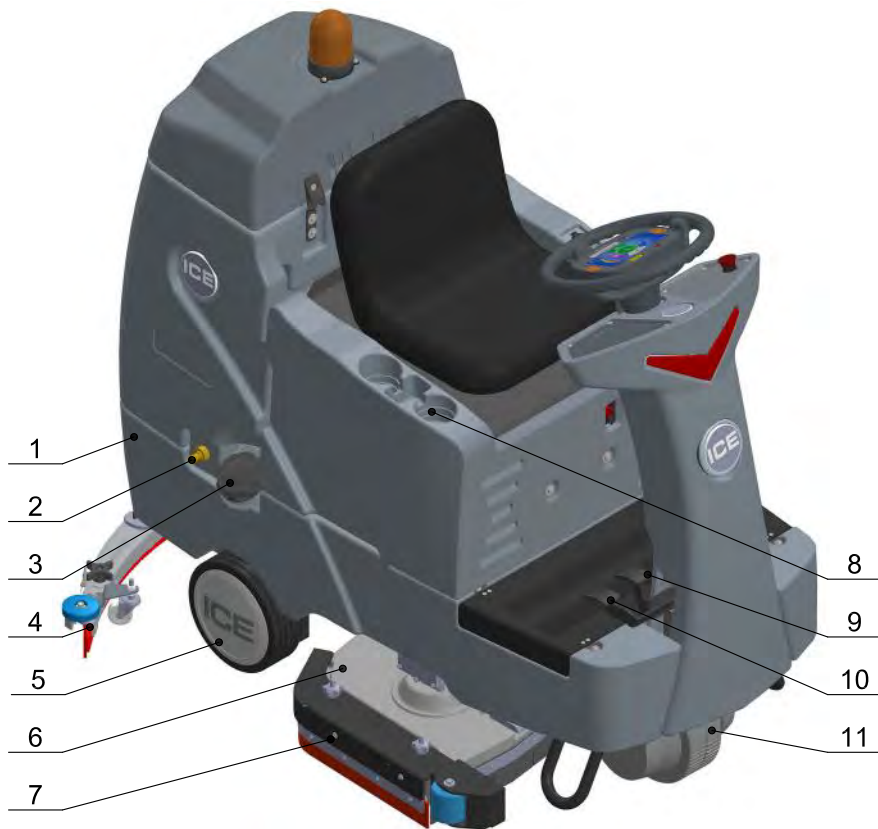

- 1. Solution tank
- 2. Auto-fill hose port (Option)
- 3. Hose fill port & Cap
- 4. Squeegee assembly
- 5. Wheels, 10 inch
- 6. Scrub head assembly
- 7. Side squeegee assembly
- 8. Cup holder
- 9. Brake pedal
- 10. Propel pedal
- 11. Front drive wheel

- 12. Operator seat
- 13. Steering wheel
- 14. Key Switch
- 15. Control panel, Touch screen
- 16. LED light, work
- 17. Emergency Stop button
- 18. Adjusting handle, seat
- 19. Off-board battery charger port (Option)
- 20. Watching window, On board battery charger
- 21. Warning light
- 22. Recovery tank cover
- 23. Recovery tank
- 24. USB Charging port
- 25. Cabin door, Detergent bottle compartment
- 26. Mesh, Battery charger power cord.

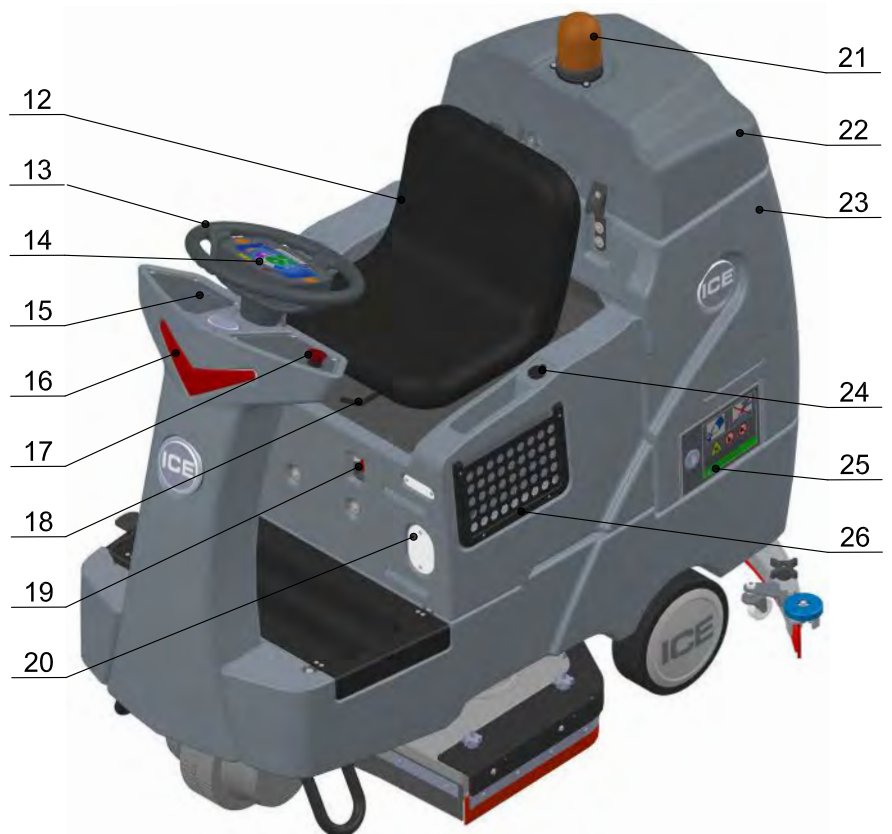

MACHINE COMPONENTS



- 27. Horn button
- 28. Battery meter
- 29. Date & Time
- 30. Solution flow adjusting button
- 31. 1-Step starting button
- 32. Work mode select button
- 33. Detergent adjusting button
- 34. Timer
- 35. Brush pressure adjusting button
- 36. Direction button
- 37. Setting button
- 38. Vacuum motor button
- 39. Fault icon
- 40. Warning light button
- 41. Drain hose, recovery tank
- 42. Vacuum hose
- 43. Drain hose, solution tank
- 44. Adjusting knob, Squeegee

MACHINE SET UP & INSTALLATION

UNCRATING MACHINE

Be sure and check packing carton for any damage. Immediately report any damage to carrier. Check the contents of package to ensure that the following items are included:

- Machine
- 4-6V Batteries
- Squeegee assembly
- 2-Pad drivers
- 2-Brushes

1. Uncrate the wooden box, place the top board on the edge of pallet, lie in the front of the machine, as below shown.



! WARNING: Do not operate machine unless you have read & understood this manual.

2. Install batteries.(see *INSTALLING BATTERIES*)
3. Turn on the Key Switch (Machine components, #14) , make sure the Squeegee assembly (Machine components, #4) and the Scrub head assembly (Machine components, #6) is off the floor.
4. Sit in the Operator seat (Machine components, #12), hold the Steering wheel (Machine components, #13), press the Propel pedal (Machine components, #10) and driving slowly the machine down from the slope.

INSTALLING BATTERIES

! WARNING: Batteries emit hydrogen gas. Explosion or fire can result from hydrogen gas.Keep sparks and open flames away! Keep battery compartment open when charging.

Recommended battery spec:
4-6V, 260AH@20HR deep cycle batteries.

Max. batteries dimensions :
300mm (L) X 180mm (W) X 290mm (H)

1. Turn the Key switch off.
2. Open and prop up the Operator seat, place the batteries into the battery compartment carefully.
NOTE: Do not drop the batteries into the compartment.
3. Connect battery cables to posts in numbered order as shown in drawing below.
NOTE: RED to POSITIVE AND BLACK to NEGATIVE.

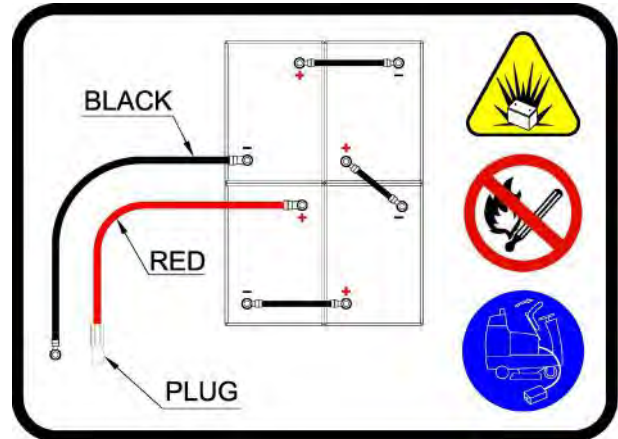

4. Reinstall the Operator seat and the Battery box.

MACHINE SET UP

INSTALLING BRUSHES OR PADS

1. Turn off the 1-Step starting button (Machine components, #31) and raise the Scrub head assembly off the floor, then stop machine on the level surface, ensure the machine is turned off.
2. If using the pad driver, first attach the appropriate pad to the pad driver surface.
3. Align the pad driver or brush under the motor hub and push it upward to engage.



4. To remove the pad driver or brush, raise the scrub head and remove the Side squeegee assembly (Machine components, #7), push the edge of brush downward.

MOUNTING THE SQUEEGEE ASSEMBLY

1. Turn off the 1-Step switch and raise the Squeegee assembly off the floor.
2. Mount the squeegee assembly to the squeegee pivot bracket. make sure the knobs are completely seated into the slots before securing knobs.
3. Connect the Vacuum hose (Machine components, #42) to the squeegee assembly. Loop the hose by using the hose clip provided.
4. Check the squeegee blades for proper adjustment by adjusting the Squeegee adjusting knob (Machine components, #44).

FILLING THE SOLUTION TANK

The machine is equipped with a Hose fill port (Machine components, #3) at the side of the machine, and a bucket fill-port located under the recovery tank.

Fill solution tank with water (not to exceed 60°C/140°F). Pour a recommended cleaning detergent into the solution tank according to mixing instructions on the container.

NOTE: Before accessing the bucket fill-port make sure that the recovery tank is empty.

When filling the solution tank with a bucket, make sure that the bucket is clean. Do not use the same bucket for filling and draining the machine.

AUTO-FILL HOSE PORT(OPTION)

The machine have a optional Auto-fill hose port (Machine components, #2), you can fill the Solution tank by using filling hose equipped with Quick connectors.

1. Connect the Quick connector of the filling hose to the Auto-fill port and connect the another end to the water supply connector.
2. Turn the water supply on, the water flow will automatically shut off when solution tank is full, and then turn the water supply off.
3. Disconnect the Quick connector from the water supply end first, and then disconnect the Filling hose from machine and store in proper location.

 **WARNING: Do not put any flammable materials into solution tank. this can cause an explosion or a fire.**

FILLING THE DETERGENT BOTTLE

The machine is equipped with a 4 liters Detergent bottle under the Recovery tank. You can fill the Detergent bottle by opening the Deterent bottle cabin door (Machine components, #25), and removing the

detergent bottle cap.

The ratio of water and detergent is 0~5%, you can adjust this ratio via pressing the Detergent adjusting button (Machine components, #33).

NOTE: Only use recommended cleaning chemicals. Contact your janitorial supply distributor for recommendations on proper chemicals.

MACHINE OPERATION

 **WARNING: Do not operate machine unless you have read and understand this manual.**

PRE-OPERATION CHECKS

1. Check the tank cover seals for damage.
2. Drain the recovery tank, check the vacuum fan inlet filter, clean them if necessary.
3. Check the vacuum hose for debris or blockage.
4. Check the squeegees for damage, wear and for deflection adjustment.
5. Check whether Pad/Brush is installed properly .
6. Check the brakes and steering for proper operation.

OPERATION THE MACHINE

1. Sit on the Operator seat, adjusting the seat to comfortable place by pushing the Seat adjustment handle (Machine components, #18).

NOTE: The machine will not travel unless the operator is sitting in the operator seat.

2. Turn on the machine.
Check the Touch screen (machine components, #15) , if the machine have fault there will have a Fault icon display and blinking (Machine components, #39), please Do Not operation the machine unless the faults have been eliminated (please see *FAULT CODES AND ELIMINATE* section).
3. Select the proper working mode by pressing the Work mode select button (Machine components, #32). The machine have 3 Modes of ECO, HEAVY Duty and User custom.

NOTE: To energy saving, recommend to using the ECO mode as possible.

For the User custom mode, you can select the preferred settings by pressing the Solution flow adjusting button (Machine components, #30), Detergent adjusting button (Machine components, #33), and the Brush pressure adjusting button (Machine components, #35).

4. Turn on the 1-Step starting button, the Scrub head assembly and the Squeegee assembly will lower down automatically, all the presetting functions will turn on.
5. The machine can scrub in both forward and backward, press the Directional button (Machine components, #36) to select the direction. The horn will sound and the squeegee will raise automatically (the vacuum motor will turn off after a short delay) when drive machine backwards. This is to prevent damaging the squeegee.
NOTE: Go slow when drive machine backwards.
6. Press the Propel pedal, the machine start scrubbing, the speed can be adjusted by controlling the force of foot stepping, light is slow, heavy is fast.
NOTE: Go slow on inclines and slippery surfaces.
7. To stop scrubbing, turn off the 1-Step starting button, the scrub head will raise automatically, the squeegee will also raise after a short delay, please keep moving until the dirty water is picked up, and then release the propel pedal and stop scrubbing.
8. Turn off the machine.

BRAKE DEVICE

The machine is driven by the Front drive wheel (Machine components, #11), that is equipped with a brake device. When you release the Propel pedal, the machine will stop travel, the park brake will engage after a short delay.

The machine is equipped with a Brake pedal (Machine components, #9), that can be used to control the machine if quicker stopping is needed or if operating on an incline.

EMERGENCY STOP BUTTON

The machine is equipped with an Emergency stop button (Machine components, #17), please push it if any emergency, that will shut off all power of machine and brake immediately.

To restart the machine, please reset the Emergency stop button, and turn off the machine and then restart.

NOTE: Please hold the steering wheel when emergency stop.

WHILE OPERATING MACHINE

 **WARNING: Fire Or Explosion Hazard. Do Not Pick Up Flammable Materials Or Reactive Metals.**

1. Go slow on inclines and slippery surfaces, go slow when turn and reverse. Do not operate the machine on inclines that exceed 7% (4°).
 2. Drive machine in a straight path as possible, avoid turning the Steering wheel too sharply when machine is in motion. avoid sudden turns except emergencies.
 3. Do not keep the machine in the same position with pad / brush spinning, keep the machine moving to prevent damage to floor finish.
 4. If the squeegee assembly leaves streaks on the floor, raise the squeegee off the floor and wipe the blades down with a damp cloth. Pre-sweep the area to prevent leaving streaks on the floor.
 5. To obtain the optimum cleaning performance, you can adjust the brush pressure, solution flow and detergent dosage as your required. If poor picking up water performance is observed, please stop scrubbing and check the squeegee blade, adjust or replace if necessary.
 6. If the dirty water path exceed the width of squeegee, please adjust the side squeegee assembly.
 7. Pour a recommended defoamer into the recovery tank if excessive foam appears.
-  **WARNING: The foam do not activate water level switch, excessive foam may result in vacuum motor damage.**
8. Press the Horn button (Machine components, #27) to alert if necessary.
 9. The machine is equipped with a Warning light (Machine components, #21), you can select turn ON or OFF by the Warning light button (Machine components, #40).
 10. If there have Fault icon display and blinking on the touch screen, please stop using the machine and to eliminate the fault (Please see FAULT CODES AND ELIMINATE section).
 11. For heavily soiled areas, please use HEAVY DUTY SCRUBBING mode by work mode select button.
 12. If you only want to pick up water needn't scrubbing, Turn on the Vacuum motor button (Machine components, #38), the squeegee will lower down, and turn off the 1-Step starting button (if it is ON), the scrub head will raise and then start to picking water up.

TANK DRAINING

DRAINING THE RECOVERY TANK

Any time scrubbing is completed, or when refilling solution tank, the recovery tank should be drained and cleaned.

 **WARNING:** If the recovery tank is not drained when the solution tank has been refilled, foam or water may enter the float shut-off screen and cause damage to the vacuum motor.

1. While holding the Recovery tank drain hose (Machine components, #41) upward, remove the cap and lower hose to drain.
2. Open the Recovery tank cover (Machine components, #22) and rinse out the tank. Use a rag to remove any excess dirt.
3. Remove and clean the vacuum fan inlet filter located in the recovery tank. Clean the filter with a damp cloth or low pressure water hose if dirty. Allow the vacuum fan filter to dry completely before reinstalling it in the machine.

DRAINING THE SOLUTION TANK

Any time scrubbing operation is completed, the solution tank should be drained and cleaned.

1. While holding the Solution tank drain hose (Machine components, #43) upward, remove the cap and lower hose to drain.
2. Rinse the solution tank with clean water after every use. This will help prevent chemical buildup and clogging of the solution lines.

BATTERY CHARGING

 **WARNING:** Fire Or Explosion Hazard. Batteries Emit Hydrogen Gas. Keep Sparks and Open Flame Away. Keep Battery Compartment Propped Open When Charging.

Use only approved chargers with the following specifications:

- Automatic shut off circuit
- Deep cycle charging
- Output current of 20-30 Amps
- Output voltage of 24 volts

ON-BOARD BATTERY CHARGER

As standard configuration, the machine is equipped with the On-board battery charger. The settings of On-board battery charger had been set for the recommended batteries type.

 **WARNING:** The On-board battery charger setting's change are to be completed by authorized service centers only. Failure to properly set will result in the batteries or charger damage.

1. Transport the machine to a well ventilated area.
2. Turn the machine off.
3. If charging wet (lead acid) batteries check the fluid level before charging.
4. Prop up the Operator seat by the support stand for ventilation.
5. Connect the charger's AC power supply cord to a properly grounded receptable.
6. The charger will automatically begin to charge, you can watching the charging status on the window (Machine components, #20), once the charging cycle begins, the indicator lights will progress from red, yellow to green. when the green indicator light comes on, the charging cycle is done. Unplug the charger cord.

NOTE: The machine will can not operate when charging.

PREVENTATIVE MAINTENANCE

 **WARNING:** Before performing any maintenance on the machine, be sure that the power is turned off, or the batteries are disconnected!

 **WARNING:** Repairs are to be completed by Authorized service centers only. Any repairs completed by unauthorized persons will void the warrenty.

DAILY MAINTENANCE

1. Remove pad driver/ brush and clean with approved cleaner.
2. Drain recovery and solution tanks completely and rinse out with clean water. Visually check the recovery tank for debris and clean out as necessary.

3. Raise the squeegee assembly off floor and wipe it down with a damp towel. Be sure to store the squeegee in the up position.
4. Remove the vacuum fan inlet filter and rinse it out with clean water.
5. Clean machine with an approved cleaner and a damp towel.
6. Recharge the batteries.
7. Check the condition of the squeegee blade wiping edge, rotate blade if worn.

MONTHLY MAINTENANCE

1. Clean the battery tops to prevent corrosion.
2. Check for loose battery cable connections.
3. Inspect and clean the recovery tank cover seal. Replace it if damaged.
4. Lubricate all grease points and pivot points with silicon spray and approved grease.
5. Check the machine for loose nuts and bolts.
6. Check the machine for leaks.

BATTERY MAINTENANCE



WARNING: Batteries emit hydrogen gas and an explosion or fire can result. Keep sparks and fire away from batteries at all times.



WARNING: Whenever servicing batteries, be sure to wear protective gloves. Avoid contact with battery acid at all times.

NOTE: For the best machine performance, keep batteries charged at all times. Do not let them sit in a discharged condition.

1. Always follow the battery charging directions as outlined in the BATTERY CHARGING section of this manual.
2. Keep battery tops and terminals free from corrosion. A strong solution of baking soda and water is the best way to keep the batteries corrosion free. **DO NOT ALLOW THE BAKING SODA / WATER SOLUTION TO ENTER THE BATTERY CELLS.**
3. Use a wire brush with the baking soda solution to properly clean the battery posts and connections.
4. Check battery connections for wear and loose terminals. replace if necessary.

MACHINE STORAGE

1. Always store the machine indoors.
2. Always store the machine in a dry area.
3. Always store the machine in its upright position.
4. Always store the machine with the pad driver/brush raised off the floor.
5. Always store the machine with the squeegee assembly raised off the floor.
6. If storing in an area which may reach freezing temperatures, be sure to drain all fluids from the machine prior to storage. Any damage caused by freezing temperatures will not be covered by the warranty.
7. Drain the recovery tank.
8. Drain the solution tank of all fluid.

FAULT CODE & SOLUTION

The machine equipped with a 7-inch touch screen (Machine components, # 15), the touch screen will display Battery meter (Machine components, #28), Date and Time (Machine components, #29), and Working accumulated hours (Machine components, #34).

When the machine detects a fault, there will have a Fault icon blinking (Machine components, #39) on the touch screen accompany an audible alarm Occasionally.

The Fault icon have 2 colors. Yellow icon represents a low level fault, you can click it to pop up a fault message window, it will guide you how to eliminate the fault.

Red icon represents a serious fault, the fault message window will pop up automatically, you can not close it unless the fault be eliminated.

Once the fault icon occurring, please **DO NOT** continue operate machine unless the faults are eliminated.

Turn off the machine, then to solve the fault, the fault icon will be eliminated when machine restart.

If the fault icon is occurred frequently, or can't be eliminated, please contact ICE service center.

Please refer to the below table to determine the fault cause and the solution.

FAULT CODE & SOLUTION

FAULT CODE	FAULT MESSAGE	SOLUTION
F01	Seat Empty	Sit in seat
F02	Squeegee or Scrub head Actuator Overload	Check Squeegee or Scrub head Actuator
F04	Vacuum Motor Overload	Check Vacuum Motor
F05	Brush Motor (Left) Overload	Check Brush Motor (Left)
F06	Brush Motor (Right) Overload	Check Brush Motor (Right)
F07	Drive Motor Overload	Check Drive Motor
F08	Recovery Tank Full	Drain Recovery tank
F09	Solution Tank Empty	Refill Solution tank
F10	Battery Low	Charge battery
F11	Battery Discharged	Charge battery Immediately
F12	Brake Open Circuit	Check brake wiring
F13	Release Accelerate Pedal	Release the propel pedal
F14	Brake Short Circuit	Check brake wiring
F16	Main Controller Overheat	Turn off the machine and re-start after a while
F18	Accelerator Sensor Open Circuit	Check accelerator sensor
F19	Brake Sensor Open Circuit	Check Brake sensor
F20	Brush Motor (Left) Open Circuit	Check Brush Motor (Left) Wiring and Connector
F21	Vacuum motor Open Circuit	Check Vacuum motor Wiring and Connector
F22	Solenoid Valve Short Circuit	Check Solenoid valve Wiring and Connector
F23	Solenoid Valve Open Circuit	Check Solenoid valve Wiring and Connector
F24	Drive Motor Open Circuit	Check Drive motor wiring and Connector
F25	Brush Motor (Right) Open Circuit	Check Brush Motor (Right) Wiring and Connector
F43	Emergency Stop	Release Emergency stop button
F49	Main Controller Fault	Replace Main controller
F50	Main Controller Fault	Replace Main controller
F53	Detergent Pump Short Circuit	Check Detergent pump Wiring and Connector
F54	Detergent Pump Open Circuit	Check Detergent pump Wiring and Connector
F55	Scrub Head Actuator Open Circuit	Check Scrub head actuator Wiring and Connector
F56	Squeegee Actuator Open Circuit	Check Squeegee actuator Wiring and Connector
F57	Flashing Light Short Circuit	Check Flashing light Wiring and Connector
F58	Flashing Light Open Circuit	Check Flashing light Wiring and Connector
F61	Main Relay (#1) Short Circuit	Check Main Relay (#1) Wiring and Connector
F62	Main Relay (#1) Open Circuit	Check Main Relay (#1) Wiring and Connector
F63	Main Relay (#2) Short Circuit	Check Main Relay (#2) Wiring and Connector
F64	Main Relay (#2) Open Circuit	Check Main Relay (#2) Wiring and Connector
F65	Drive Motor Short Circuit	Check Drive Motor Wiring and Connector
F67	Brush Motor (Left) Short Circuit	Check Brush Motor (Left) Wiring and Connector
F68	Brush Motor (Right) Short Circuit	Check Brush Motor (Right) Wiring and Connector
F69	Vacuum Motor Short Circuit	Check Vacuum Motor Wiring and Connector
F70	Scrub Head Actuator Short Circuit	Check Scrub head actuator Wiring and Connector
F71	Squeegee Actuator Short Circuit	Check Squeegee actuator Wiring and Connector

TECHNICAL SPECIFICATIONS

MODEL	RS26+	RS32+
LENGTH	63.4 in / 1,610 mm	
WIDTH (MACHINE WITH SCRUB HEAD)	33 in / 838 mm	36.5 in / 927 mm
HEIGHT	56.7 in / 1,440 mm	
WEIGHT	618 lbs / 280 Kg	640 lbs / 290 Kg
WEIGHT WITH BATTERIES	880 lbs / 400 Kg	900 lbs / 410 Kg
RECOVERY TANK CAPACITY	27.7 Gal / 105 L	
SOLUTION TANK CAPACITY	28.5 Gal / 108 L	
SQUEEGEE WIDTH	33.8 in / 860 mm	40 in / 1,030 mm
CLEANING PATH WIDTH	26 in / 650 mm	32 in / 810 mm
PRODUCTIVITY RATE PER HOUR (IN THEORY)	46,300 ft ² 4,300 m ²	55,600 ft ² 5,200 m ²
TRAVEL SPEED (TRANSPORT)	4 Mile / h 6.5 Km / h	
MINIMUM AISLE TURN	71 in / 1,800 mm	75 in / 1,900 mm
PAD/BRUSH PRESSURE	80 lbs / 35 Kg 120 lbs / 55 Kg 160 lbs / 75 Kg	
SOLUTION FLOW	0 ~ 0.7 Gal / Min 0 ~ 2.7 L / Min	
BATTERIES	4 x 6V , 240AH@ 20Hr 4 x 6V , 305AH@ 20Hr (FOR US MARKET)	
VOLTAGE	24V DC	
DRIVE WHEEL	1.1 hp / 0.8 KW	
BRUSH MOTOR	(2) 0.6 hp / 0.45 KW, 210 RPM	
VACUUM MOTOR	0.6 hp / 0.45KW	
VACUUM WATER LIFT (MAX)	70 in. H ₂ O / 1780 mm. H ₂ O	
RUN TIME PER CHARGE	3~3.5 Hours	
DECIBEL RATING AT OPERATOR'S EAR, INDOORS	68 dB(A)	
GRADE LEVEL, MAX	Scrubbing: 4°/7%	Transporting (empty):10°/17.5%

MAIN FRAME GROUP

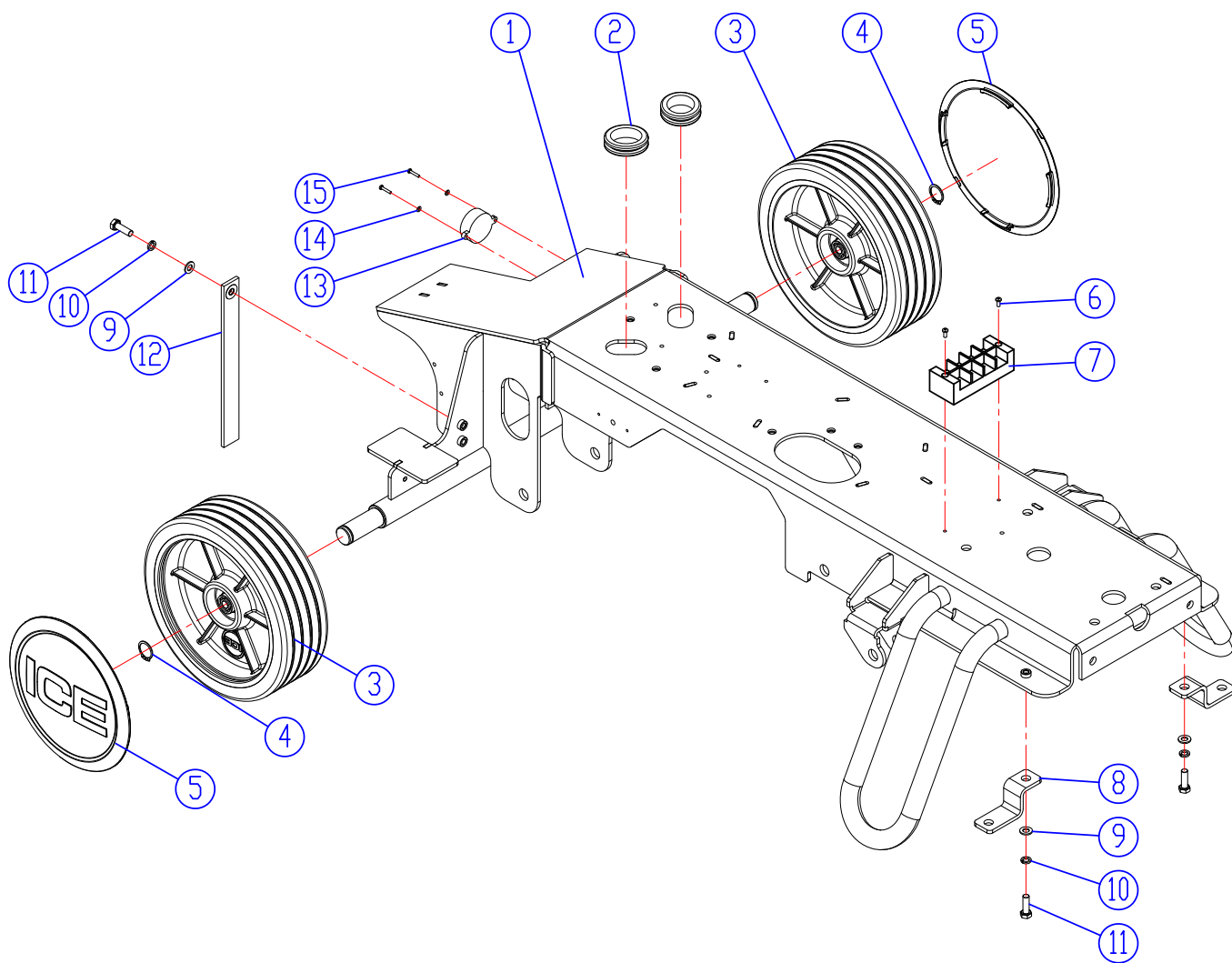

MAIN FRAME GROUP

DIA NO.	PART NUMBER	DESCRIPTION	SERIAL NUMBER	NO REQ'D
1	8320150	MAIN FRAME, WELDED		1
2	8310133	RUBBER GROMMET		4
3	8310119	10" WHEEL, PU TIRE		2
	1612605	BALL BEARING,6205-2RS		4
	8315250	10" WHEEL, ANTI-SLIP, OPTION		2
4	1436025	RETAINING RING, 25MM		2
5	8310150	WHEEL CAP		2
6	1521410	SCREW, SOCKET, M4x10		2
7	1883207	BARRIER TERMINAL BLOCK		1
8	8310120	BRACKET, STAND		2
9	1421824	FLAT WASHER, M8x ϕ 24x2.0		3
10	1422821	LOCK WASHER M8		3
11	1021825	BOLT, HEX, M8x25		3
12	8210118	STATIC STRAP		1
13	8310708A	HORN, 24VDC, KIT		1
14	1421307	FLAT WASHER, M3x ϕ 7x0.5		4
15	1221312	SCREW, PAN HEAD, M3x12		2

STEERING & DRIVE WHEEL GROUP

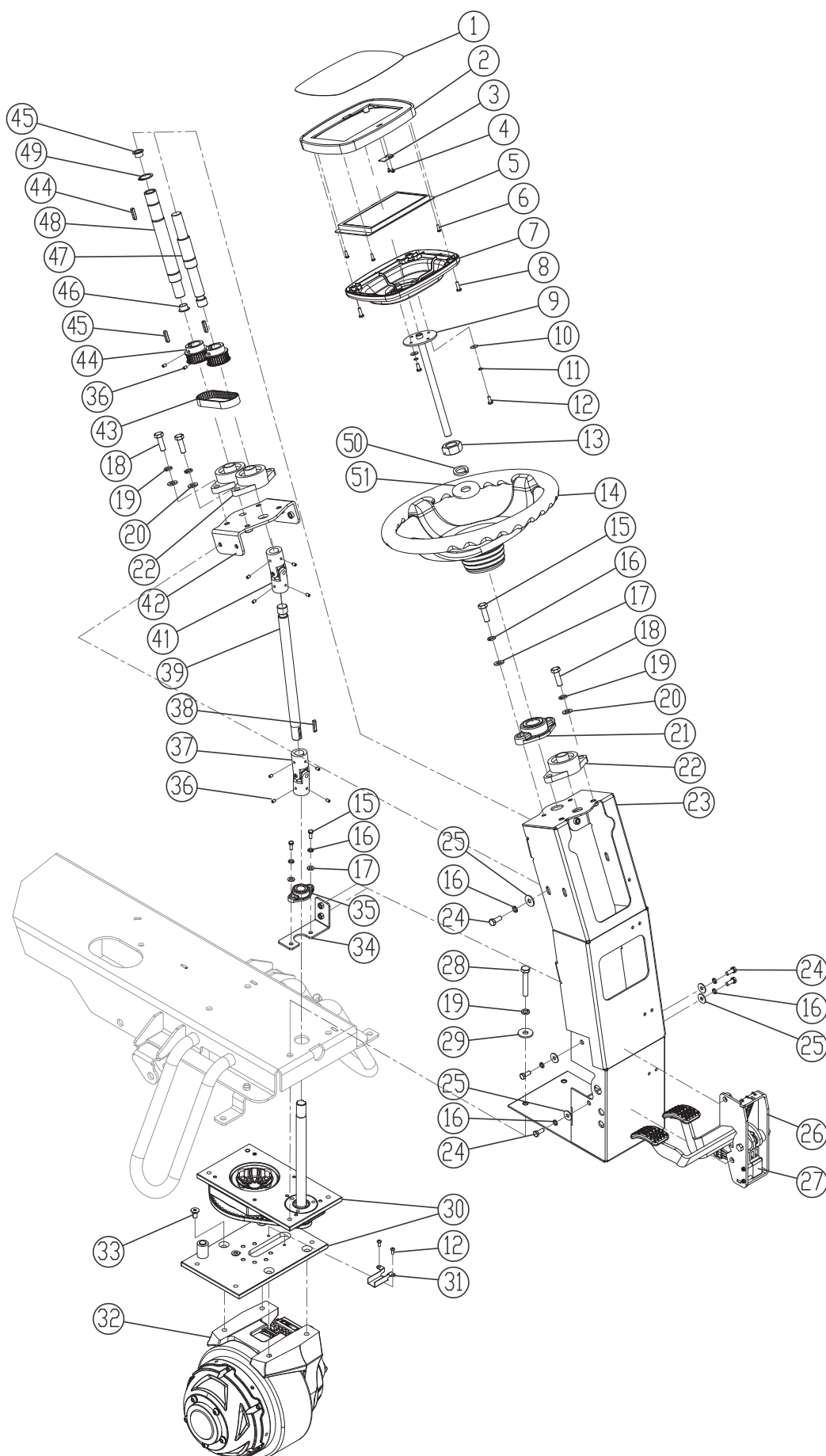

STEERING & DRIVE WHEEL GROUP

DIA NO.	PART NUMBER	DESCRIPTION	SERIAL NUMBER	NO REQ'D
1	8313704	DECAL, TOUCH SCREEN PANEL		1
2	8313703	COVER, TOUCH SCREEN		1
3	8313723	FPC CONNECTOR		1
4	1311006	SELF-TAPPING CREW, ST3.0x6.0		2
5	8313712B	TOUCH SCREEN, ENGLISH UI		1
6	1221306	SCREW, M3x6		4
7	8313702	BASE, TOUCH SCREEN		1
8	1221516	SCREW, M5x16		4
9	8313701	TUBE WITH FLANGE		1
10	1421515	FLAT WASHER, M5x ϕ 15x1.0		4
11	1422513	LOCK WASHER, M5		4
12	1221512	SCREW, PAN HEAD, M5x12		6
13	8313612	HEX NUT, M24		1
	1111221	HEX NUT, M22	60308100135~ 60309100157~	1
14	8313610	STEERING WHEEL		1
15	1021830	BOLT, HEX HEAD, M8x30		4
16	1422821	LOCK WASHER, M8		12
17	1421816	FLAT WASHER, M8x ϕ 16x1.6		4
18	1021035	BOLT, HEX HEAD, M10x35		6
19	1422026	LOCK WASHER, M10		10
20	1421020	FLAT WASHER, M10x ϕ 20x2		6
21	8313609	FLANGE BEARING, PLASTIC		1
22	8313608	FLANGE BAEARING		3
23	8313601	STEERING SUPPORT		1
24	1021820	BOLT, HEX HEAD, M8x20		8
25	1421824	FLAT WASHER, M8x ϕ 24x2.0		8
26	8310640	ACCELERATOR & BRAKE ASSEMBLY		1
27	8310431	HALL SENSOR WITH CABLE		1
28	1021050	BOLT, HEX HEAD, M10x50		4
29	1421030	FLAT WASHER, M10x ϕ 30x2.5		4
30	8320685	STEER-CONTROL ASSEMBLY		1

STEERING & DRIVE WHEEL GROUP

DIA NO.	PART NUMBER	DESCRIPTION	SERIAL NUMBER	NO REQ'D
31	8310687	BRACKET, WIRING		1
32	8310680A	DRIVE WHEEL, 24VDC (GREY WHEEL)		1
	8310681	GREY WHEEL REPLACEMENT FOR 8310680		1
	8310625A	BRAKE KIT FOR 8310680A		1
	8311690	DRIVE WHEEL, 24VDC (BLUE WHEEL)	60031100159~60031100232 60026100139~60026100167	1
	8311690-2	BLUE WHEEL REPLACEMENT FOR 8311690		1
	8311690-5	BRAKE KIT FOR 8311690		1
33	1513020	SCREW, HEX SOCKET, M10x20		4
34	8310645	BRACKET, FLANGE BEARING		1
35	8310609	BEARING, FLANGE		1
36	1534508	SET SCREW, M5 x8		8
37	8310604	U-JOINT		1
38	1654025	KEY, 4.75x4.75x25.4		2
39	8313621	SHAFT, STEERING		1
	8313624	SHAFT, STEERING	60308100135~ 60309100157~	1
40	1531830	HEX SOCKET CAPHEAD SCREW, M8x30		2
41	8313620	U-JOINT		1
	8313614	U-JOINT	60308100135~ 60309100157~	1
42	8313602	BRACKET, FLANGE BEARING		1
43	8313607	BELT		1
44	8313606	PULLEY		2
45	1655025	KEY, 5x5x25		3
46	8313611	BUSHING		2
47	8313622	SHAFT, PULLEY		1
	8313625	SHAFT, PULLEY	60308100135~ 60309100157~	1
48	8313605	SHAFT , PULLEY		1
49	1436025	RETAINING RING, 25MM		3
50	1422226	WASHER LOCK Φ 22		1
51	1421229	FLAT WASHER, Φ 22x Φ 39x3		1

SOLUTION TANK GROUP

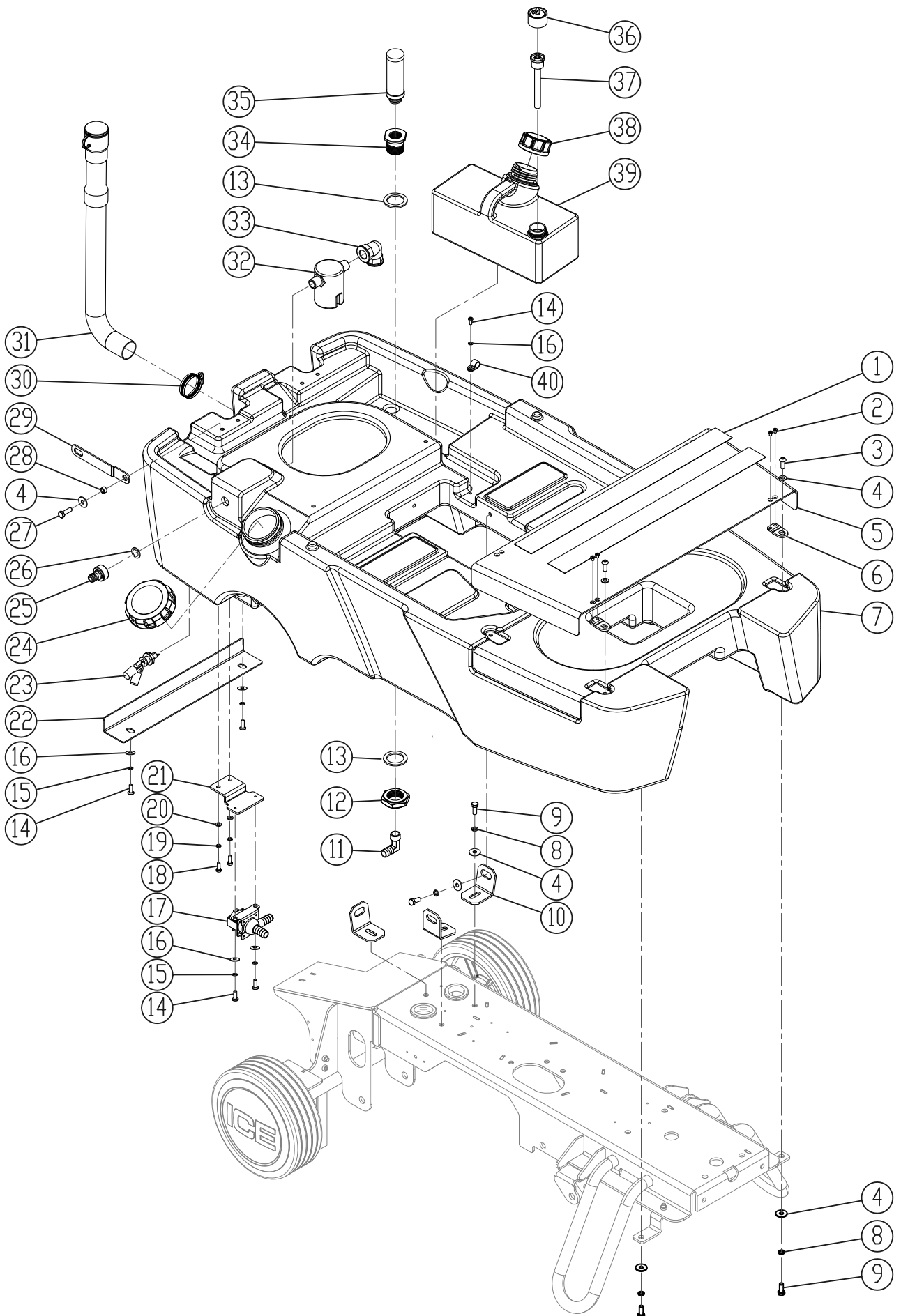

SOLUTION TANK GROUP

DIA NO.	PART NUMBER	DESCRIPTION	SERIAL NUMBER	NO REQ'D
1	8310132	NON-SLIT MAT		2
2	1222508	SCREW, M5x8		8
3	1512820	SCREW, HEX SOCKET M8x20		4
4	1421824	FLAT WASHER, M8x ϕ 24x2.0		13
5	8320102	FOOTREST PLATE		1
6	8310140	JUNCTION PLATE		4
7	8320101	SOLUTION TANK		1
8	1422821	SPRING LOCK WASHER, M8		8
9	1021820	BOLT, HEX HEAD, M8x20		8
10	8310130	BRACKET, SOLUTION TANK MNTG		3
11	8310124	ELBOW, G1/2		1
12	8310142	NUT, M36		1
13	8310141	SEALING		2
14	1221512	SCREW, PAN HEAD, M5x12		9
15	1422513	LOCK WASHER, M5		4
16	1421510	FLAT WASHER, M5x ϕ 10x1.0		9
17	8311310C	SOLENOID VALVE		1
18	1021616	BOLT, HEX HEAD, M6x16		2
19	1422616	LOCK WASHER M6		2
20	1421612	FLAT WASHER, M6x ϕ 12x1.6		2
21	8320105	BRACKET		1
22	8320128	BRACKET, PROTECTIVE		4
23	8310238A	SENSOR, SOLUTION LEVEL, KIT		1
24	8310125	CAP, SOLUTION TANK		1
25	8320123	QUICK CONNECTOR G1/2		1
26	8320127	GASKET		1
27	1021825	BOLT, HEX HEAD, M8x25		1
28	8310225	SLEEVE, ϕ 8.1x ϕ 12.7x7.8		1
29	8320104	ARM, RECOVERY TANK SUPPORT		1
30	1962050	CLAMP, 2 INCH		1
31	8011040	DRAIN HOSE, BLACK		1
	8011041	DRAIN HOSE, BLACK		
	8320106	DRAIN HOSE, TRANSPARENT, OPTION		
32	8320121	FLOAT VALVE		1
33	8320122	ELBOW, G1/2		1
34	8310123	ADAPTER, STRAINER ASSEMBLY		1
35	8310122	STRAINER		1
36	8310463	CAP ADAPTER		1
37	8310464	INSERT TUBE		1
38	8310462	CAP, BOTTLE		1
39	8320901	DETERGENT TANK		1
40	8113009	CLAMP, NYLON		5

NOTE:

- ① DIA NO.22 Bracket is deprecated for design requirements.
- ② DIA NO.31 P/N:8011040 Drain hose has replaced by P/N:8011041.

RECOVERY TANK GROUP

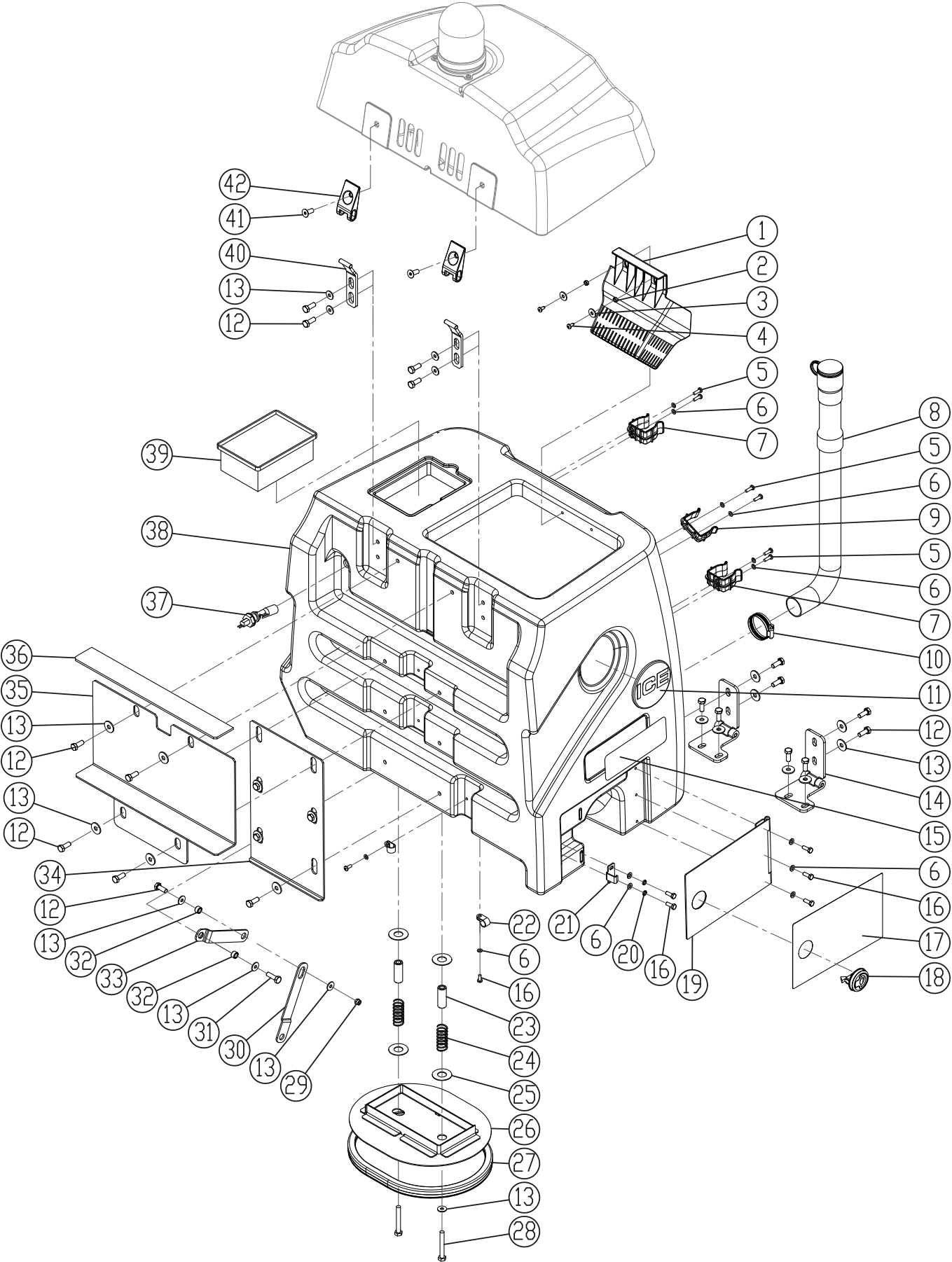

RECOVERY TANK GROUP

DIA NO.	PART NUMBER	DESCRIPTION	SERIAL NUMBER	NO REQ'D
1	8310250	DEBRIS COLLECTOR		1
2	8012008	BUSHING		2
3	1421618	FLAT WASHER, M6x ϕ 18x1.6		2
4	1321413	SELF-TAPPING, ST4.8 x 13		2
5	1221516	SCREW, PAN HEAD, M5X16		8
6	1421510	FLAT WASHER, M5x ϕ 10x1.0		21
7	6210111	CLAMP, HOSE		2
8	8011040	DRAIN HOSE,BLACK		1
	8011041	DRAIN HOSE,BLACK		
9	2310129	CLAMP, HOSE		2
10	1962050	CLAMP, 2 INCH		1
11	4010316	ICE LOGO		2
12	1021820	BOLT, HEX HEAD, M8x20		21
13	1421824	FLAT WASHER, M8x ϕ 24x2.0		25
14	8310126	HINGE ASSY.		2
15	8130099	DECAL, I-SYNERGY		2
16	1221512	SCREW, PAN HEAD, M5x12		13
17	8320903	DECAL, DETERGENT INSTRUCTION		1
18	8320211	LOCK WITH HINGE		1
19	8320210	COVER		1
20	1422513	LOCK WASHER, M5		4
21	8320224	HOOK, LOCK		1
22	8113009	CLAMP, NYLON		8
23	8310221	SPACER		2
24	8310220	COMPRESSION SPRING		2
25	8310222	FLAT WASHER, LARGE		4
26	8320220	COVER, SOLUTION TANK		1
27	8320223	SEALING STRIP		1
28	1022860	BOLT, HEX HEAD, M8x60		2
29	1123810	LOCK NUT, M8		1
30	8320104	ARM, RECOVERY TANK SUPPORT		1
31	1021825	BOLT, HEX HEAD,M8x25		1
32	8310225	SLEEVE, ϕ 8.1x ϕ 12.7x7.8		2
33	8320203	ARM, RCOVERY TANK SUPPORT		1
34	8310215	RECOVERY TANK SUPPORT		1
35	8310211	BRACKET, SUPPORT		1
36	8310214	SPACER, RUBBER		1
37	8310238A	SENSOR, SOLUTION LEVEL, KIT		1
38	8320201	RECOVERY TANK		1
39	8310237	FILTER, DUST		1
40	8310227	HINGE, WELDED		2
41	1513820	SCREW, HEX SOCKET, M8x20		2
42	8310226	HINGE, LEAF		2

RECOVERY TANK COVER GROUP

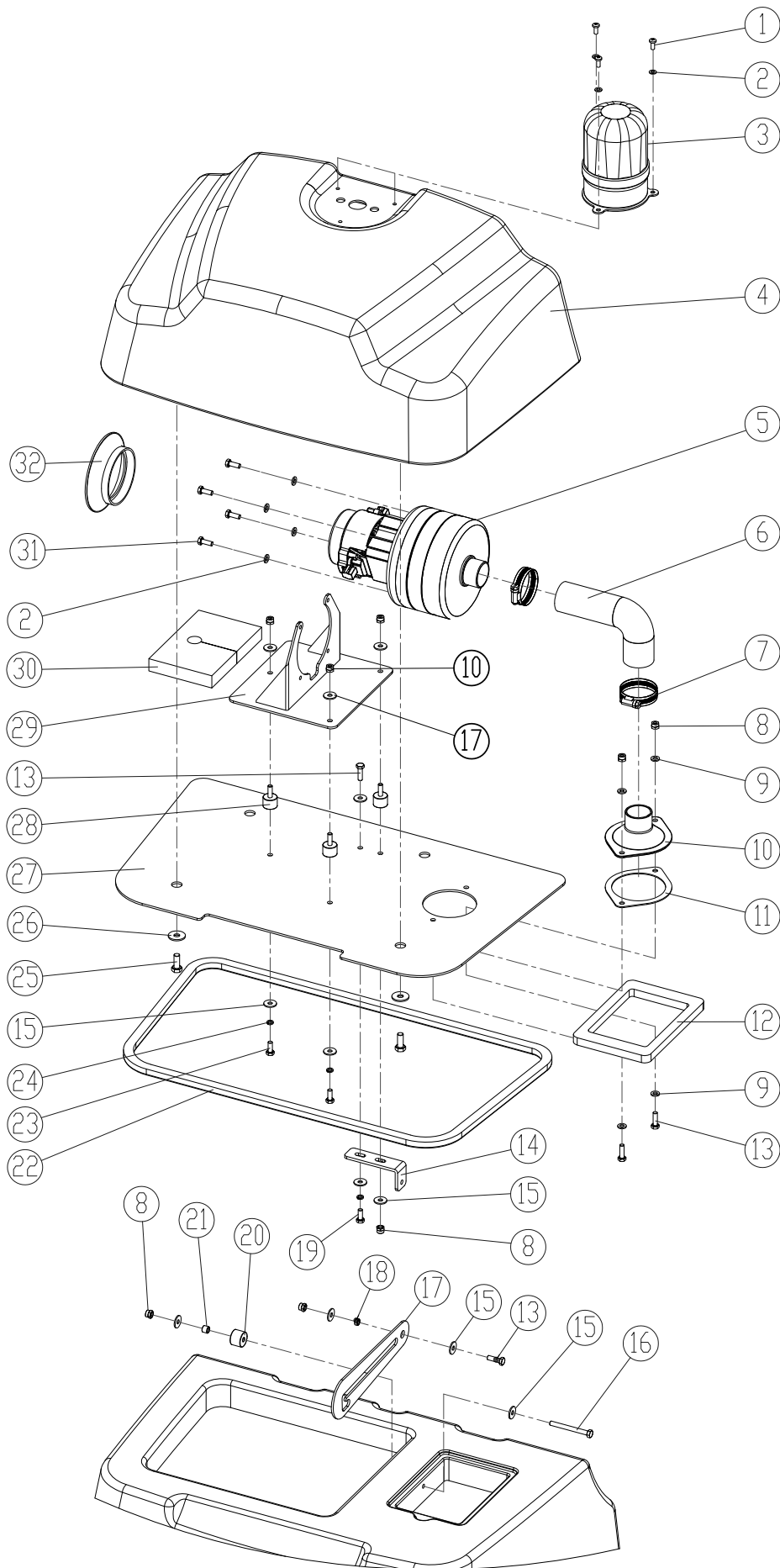

RECOVERY TANK COVER GROUP

DIA NO.	PART NUMBER	DESCRIPTION	SERIAL NUMBER	NO REQ'D
1	1221512	SCREW, PAN HEAD, M5x12		3
2	1421510	FLAT WASHER, M5xφ10x1.0		7
3	8310165A	CAUTION LIGHT, KIT		1
4	8310202	RECOVERY TANK COVER		1
5	8310210	VACUUM MOTOR, 3 STAGE, KIT		1
	8112008	CARBON BRUSH FOR 8310210		2
6	8310207	VACUUM HOSE		1
7	1962050	CLAMP, 2 INCH		2
8	1123608	LOCK NUT, M6		8
9	1421612	FLAT WASHER, M6xφ12x1.6		4
10	8310204	ADAPTER, VACUUM HOSE		1
11	8310205	GASKET, ADAPTER		1
12	8310230	GASKET, DUST FILTER		1
13	1021620	BOLT, HEX HEAD, M6x20		4
14	8310232	BRACKET		1
15	1421618	FLAT WASHER, M6xφ18x1.6		12
16	1022600	BOLT, HEX HEAD, M6x100		1
17	8310228	SUPPORT, RECOVERY TANK COVER		1
18	8310231	SLEEVE, φ6.4xφ9.5x4		1
19	1021616	BOLT, HEX HEAD, M6x16		1
20	8310236	SPACER, NYLON		1
21	8310235	SLEEVE, φ6.4xφ9.5x8		1
22	8310229	SEALING STRIP		1
23	1021610	BOLT, HEX HEAD, M6x10		2
24	1422616	LOCK WASHER, M6		3
25	1021820	BOLT, HEX HEAD, M8x20		4
26	1421824	FLAT WASHER, M8xφ24x2.0		4
27	8310203	PLATE, VACCUM MOTOR MNTG		1
28	8310208	ISOLATER, M6		3
29	8310209	BRACKET, VACCUM MOTOR		1
30	8310234	INSULATION		1
31	1311316	SCREW, SELF-TAPPING, ST4.8x16		4
32	8310206	SEAL, FAN		1

CONTROL PANEL GROUP

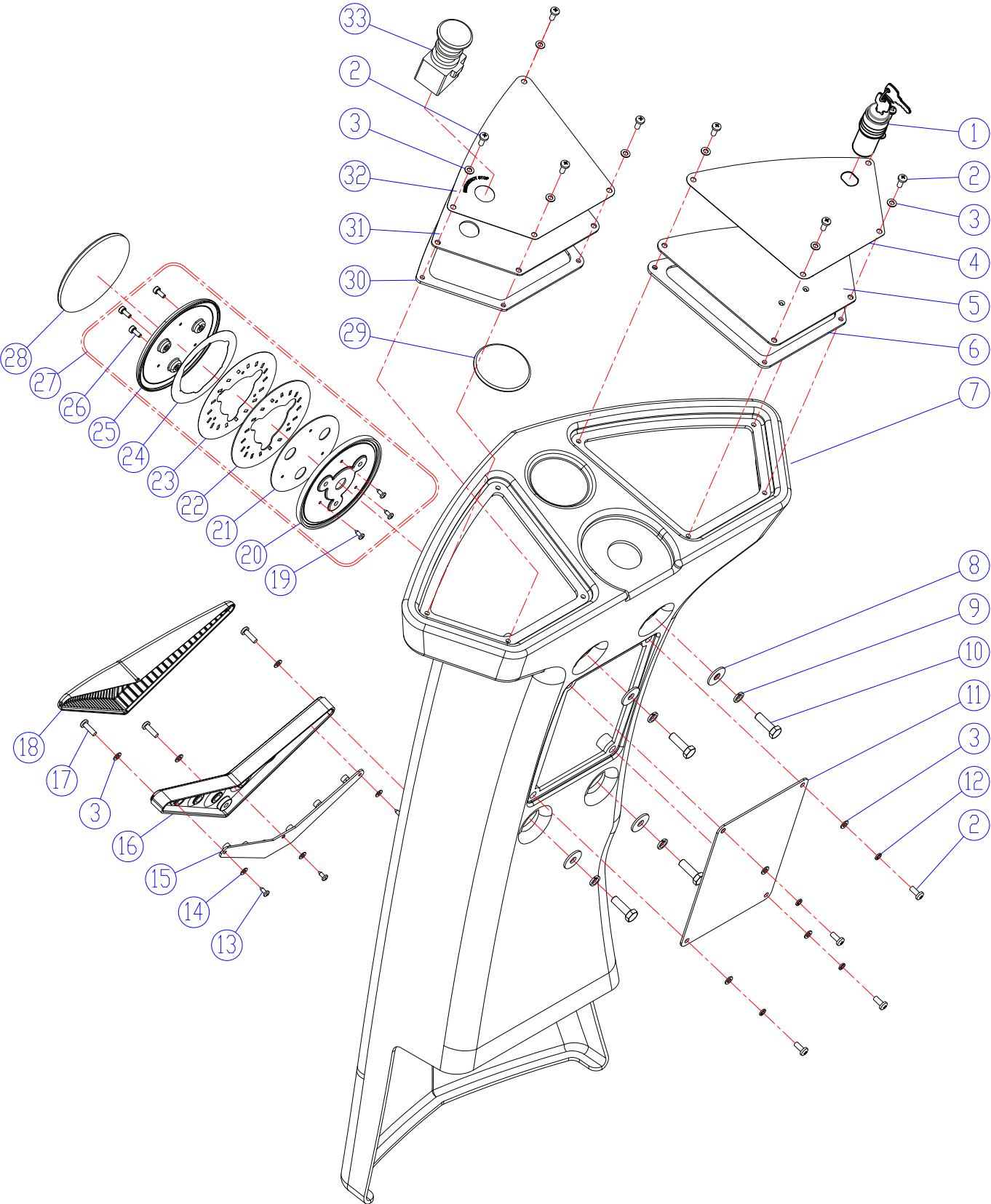

CONTROL PANEL GROUP

DIA NO.	PART NUMBER	DESCRIPTION	SERIAL NUMBER	NO REQ'D
1	8310706A	MAIN KEY SWITCH		1
2	1221512	SCREW, PAN HEAD, M5×12		12
3	1421510	FLAT WASHER, M5.3× ϕ 10×1.0		15
4	8313708	DECAL, CONTROL PANEL		1
5	8313706	PLATE, CONTROL PANEL		1
6	8310712	GASKET, CONTROL PANEL		1
7	8313730	CONROL HOUSING		1
8	1421824	FLAT WASHER, M8× ϕ 24×2.0		4
9	1422821	LOCK WASHER, M8		4
10	1021825	BOLT, HEX HEAD, M8×25		4
11	8313711	COVER		1
12	1422513	SPRING LOCK WASHER, M5		4
13	1321110	SCREW, SELF-TAPPING, ST3.5×10		3
14	1421409	FLAT WASHER, M4× ϕ 9×0.8		3
15	8133610	LED LIGHT, KIT		1
16	8133601	BASE, LED LIGHT		1
17	1221520	SCREW, PAN HEAD, M5×20		3
18	8133602	COVER, LED LIGHT		1
19	1311006	SELF-TAPPING CREW, ST3.0×6.0		3
20	8230401	BASD, LED LIGHT		1
21	8230403	LED PCB		1
22	8230405	LIGHT GUIDE PLATE		1
23	8230404	REFLECTOR		1
24	8230406	DISPERSE PIECE		1
25	8230402	COVER, LED LIGHT		1
26	1521410	SCREW, SOCKET HEAD, M4×10		3
27	8230400	LED LIGHT KIT		1
28	4010316	ICE LOGO		1
29	2010121	ICE LOGO, SMALL		1
30	8310755	GASKET, SWITCH PANEL		1
31	8313705	PLATE, LEFT SWITCH PANEL		1
32	8313707	DECAL, LEFT CONTROL PANEL		1
33	8310707	EMERGENCY STOP SWITCH		1

CONTROLLER GROUP

DIA NO.	PART NUMBER	DESCRIPTION	SERIAL NUMBER	NO REQ'D
1	1021616	SCREW, HEX HEAD, M6x16		12
2	1422616	LOCK WASHER, M6		20
3	1421618	FLAT WASHER, M6x ϕ 18x1.6		14
4	8310480	FUSE, 150A		1
5	8114705	INSULATOR		3
6	8310422	BRACKET, INSULATOR		2
7	8310133	RUBBER GROMMET		4
8	8310740	CIRCUIT BREAKER, 5A		2
9	1021820	BOLT, HEX HEAD, M8x20		4
10	1422821	SPRING LOCK WASHER, M8		9
11	1421828	FLAT WASHER, M8x ϕ 28x2.5		9
12	1123507	LOCK NUT, M5		4
13	1421510	FLAT WASHER, M5.3x ϕ 10x1.0		8
14	8320454	BRACKET, CHARGER		1
15	8210106A	ON BOARD BATTERY CHARGER, 25A		1
	8350525	BATTERY CHARGER, FOR Trojan BATTERIES	RS26+ 100204 ~ UP RS32+ 100261 ~ UP	1
16	1221520	SCREW, PAN HEAD, M5x20		4
17	8312060US	CHARGER POWER CORD, US		1
18	1211330	SCREW, PAN HEAD, M3x30		2
19	8310425	BRACKET		2
20	8320450	BRACKET, SCRUB HEAD LIFTING		1
21	1021825	BOLT, HEX HEAD, M8x25		5
22	1123305	LOCK NUT, M3		4
23	1434300	WASHER, TOOTH, M3		4
24	8310423	MICRO SWITCH		1
25	1421307	FLAT WASHER, M3x ϕ 7x0.5		2
26	1211320	SCREW, PAN HEAD, M3x20		2
27	8113020	CONNECTOR		1
28	1423612	FLAT WASHER M6x ϕ 12x1		10
29	1023612	HEX BOLT M6 x 12, COPPER		10
30	1421409	FLAT WASHER, M4x ϕ 9x0.8		4
31	1422411	LOCK WASHER, M4		4
32	1221416	SCREW, HEX HEAD, M4x16		4
33	8313421	CONNECT PLATE		1
34	8313420	RELAY, 24VDC 120A		2
35	8313400	MAIN CONTROLLER		1
36	8320453	BRACKET, MAIN CONTROLLER		1

SEAT GROUP

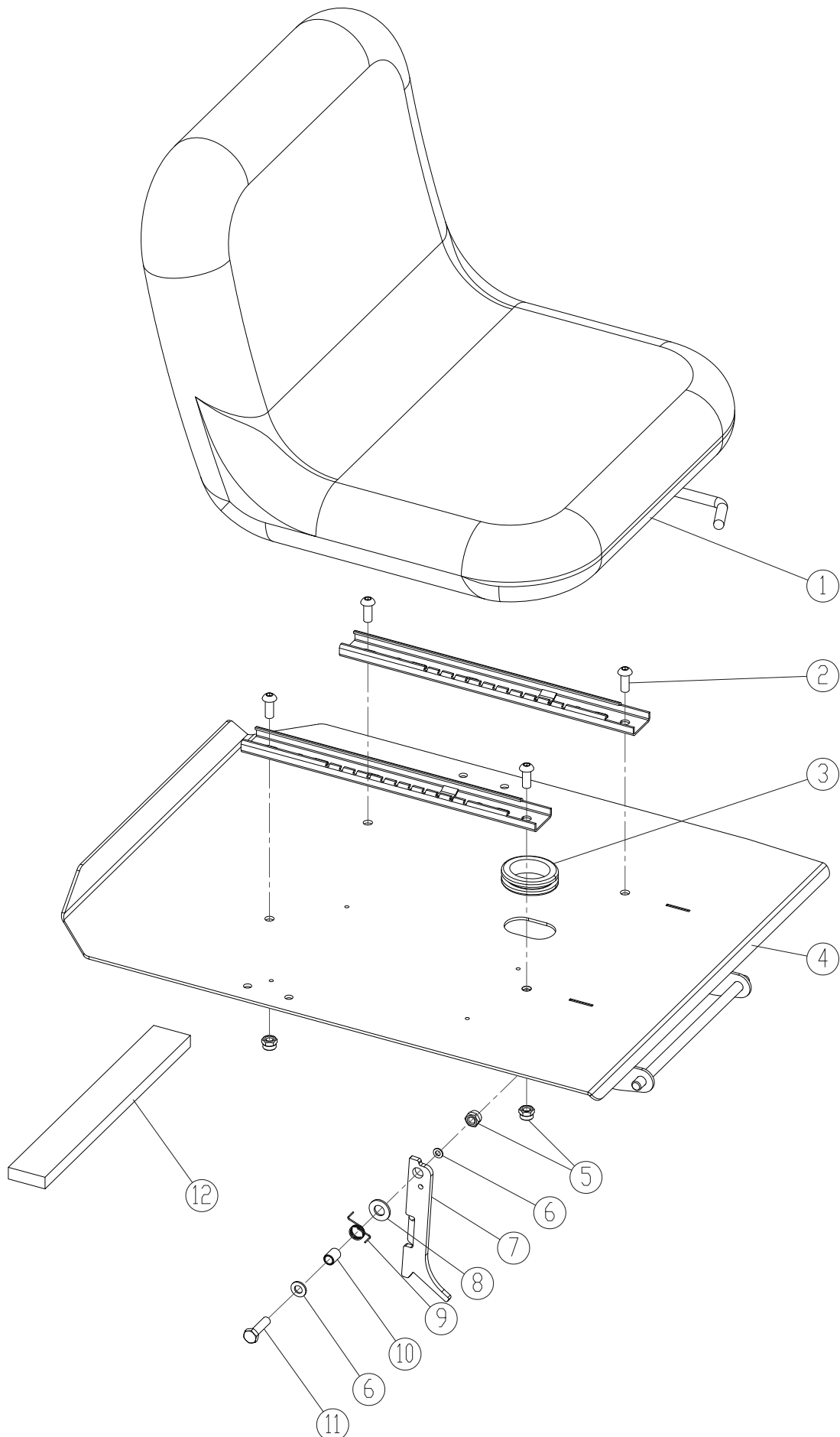

SEAT GROUP

DIA NO.	PART NUMBER	DESCRIPTION	SERIAL NUMBER	NO REQ'D
1	8310402K	SEAT, KIT		1
	8310402A	SAFTEY SEAT SWITCH		1
2	1512820	SCREW, HEX SOCKET, M8x20		4
3	8310133	RUBBER GROMMET		1
4	8310411	PLATE, SEAT MNTG		1
5	1123810	LOCK NUT M8		5
6	1421816	FLAT WASHER, M8x ϕ 16x1.0		2
7	8310413	SUPPORT, SEAT		1
8	8117007	NYLON SPACER		1
9	8310415	TORSION SPRING		1
10	8310414	SLEEVE, ϕ 8.2x ϕ 11x15		1
11	1031830	BOLT, HEX HEAD, M8x30		1
12	8310460	SPACER		1

BATTERY GROUP

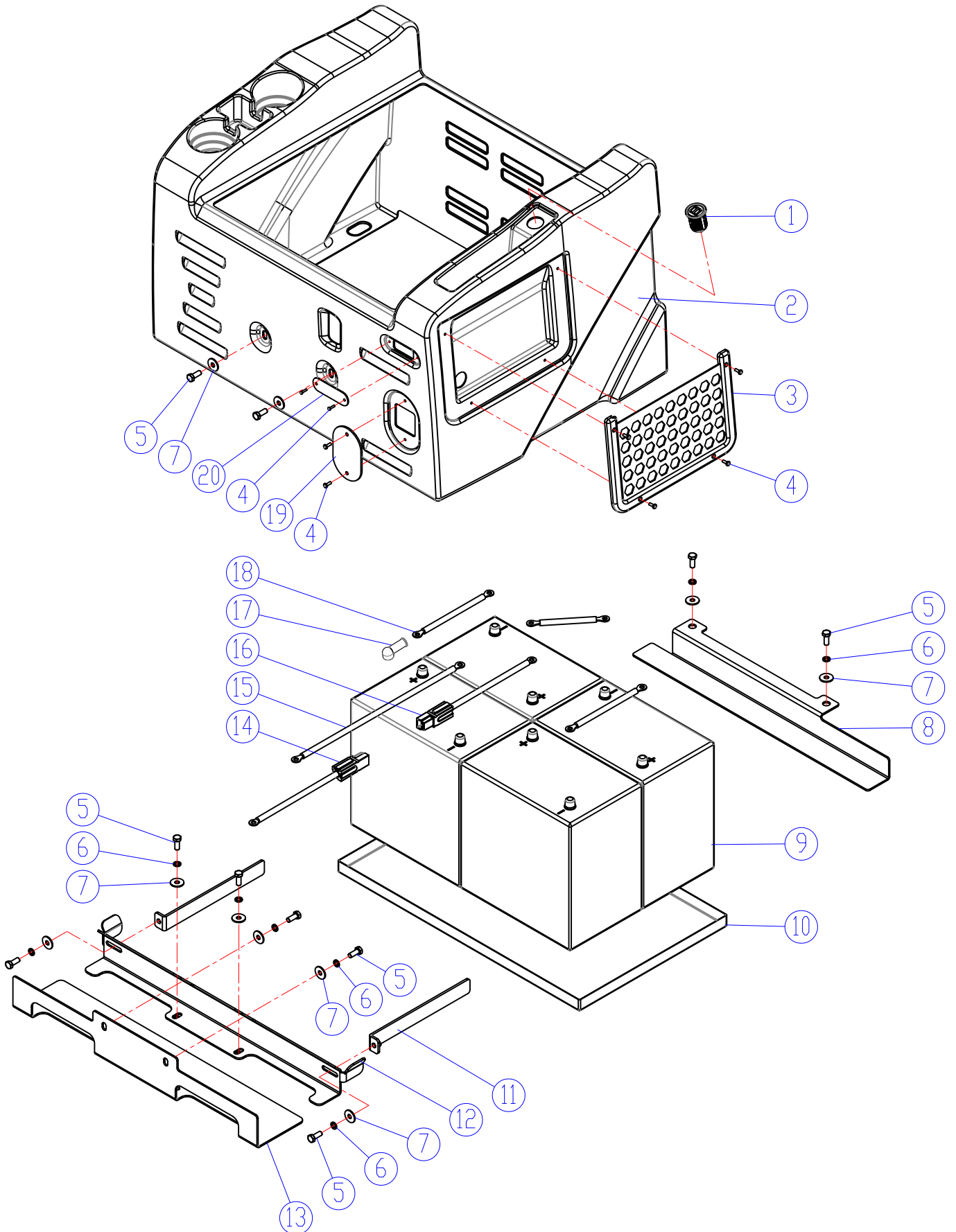

BATTERY GROUP

DIA NO.	PART NUMBER	DESCRIPTION	SERIAL NUMBER	NO REQ'D
1	8320420	USB CHARGE PORT		1
2	8320401	BOX, BATTERY		1
3	8320411	CARGO MESH		1
4	1221410	SCREW, PAN HEAD, M4x10		8
5	1021820	BOLT, HEX HEAD, M8x20		10
6	1422821	SPRING LOCK WASHER, M8		8
7	1421824	FLAT WASHER, M8xφ24x2.0		10
8	8320103	SUPPORT, BATTERY, REAR		1
9		BATTERY, 6V, FOR US MARKET *Please contact ICE(US) for part number.		4
10	8310135	TRAY, BATTERY		1
11	8310407	PLATE		2
12	8320452	SUPPORT, BATTERY, FRONT		1
13	8320451	FIXED BOARD, BATTERY		1
14	8310736	BATTERY CONNECT CABLE, RED		1
15	8310733	BATTERY CONNECT CABLE, BLACK		1
16	8310737	BATTERY CONNECT CABLE, RED		1
17	8114751	JACKET, BATTERY TERMINAL, BLACK		8
18	8210141	BATTERY CONNECT CABLE, BLACK		3
19	8210114	COVER		1
20	8134061	SCREEN, CHARGER		1
	8134069	SCREEN, CHARGER	60026100139~ 60031100161~	1

SCRUB HEAD LIFTING GROUP

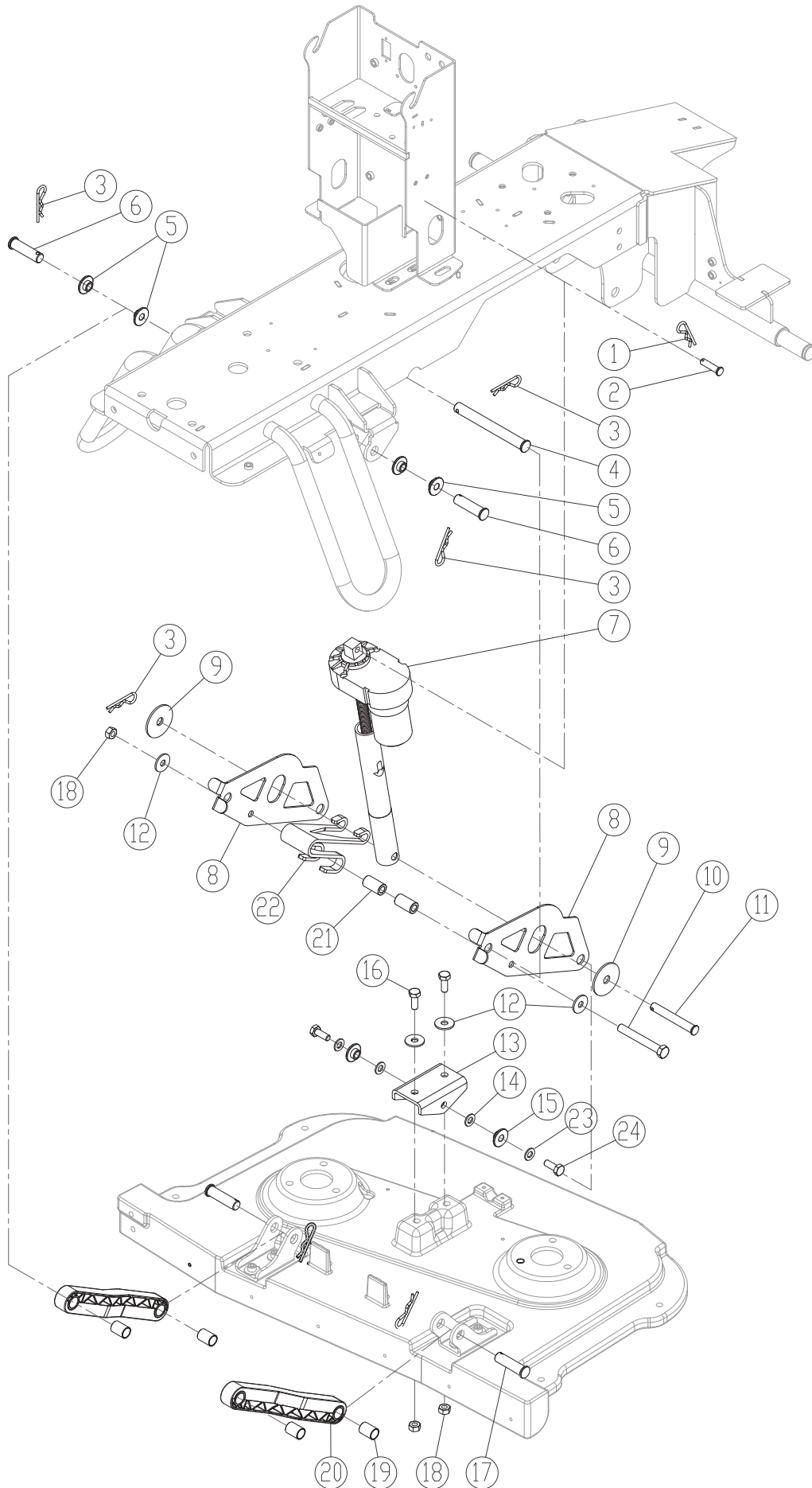

SCRUB HEAD LIFTING GROUP

DIA NO.	PART NUMBER	DESCRIPTION	SERIAL NUMBER	NO REQ'D
1	8310320	PIN, COTTER		1
2	8210301	PIN, $\phi 9.5 \times 38$		1
3	8210309	PIN, COTTER		6
4	8310311	PIN, $\phi 16 \times 150$		1
5	8320129	BUSHING		4
6	8320131	PIN, $\phi 16 \times 63$		4
7	8310303A	LINEAR ACTUATOR, KIT		1
8	8310305	PLATE, ARM, SCRUB HEAD LIFTING		2
9	8310314	FLAT WASHER, LARGE		2
10	1032090	BOLT, HEX HEAD, M10 \times 90		1
11	8310313	PIN, $\phi 12 \times 90$		1
12	1421030	FLAT WASHER, M10 \times $\phi 30 \times 2.5$		4
13	8310304	BRACKET, SCRUB HEAD LIFTING		1
14	1421020	FLAT WASHER, M10 \times $\phi 20 \times 2$		2
15	8310307	BUSHING, FLANGE		2
16	1011025	BOLT, HEX HEAD, M10 \times 25		4
17	8310312	PIN, $\phi 16 \times 57$		2
18	1123012	LOCK NUT, M10		3
19	8310144	SLEEVE, $\phi 16 \times \phi 18.6 \times 25.4$		4
20	8310118	ARM, SCRUB HEAD LIFTING		2
21	8310306	SLEEVE, $\phi 10.5 \times \phi 18.5 \times 34$		2
22	8310308	SPRING		1
23	1422026	LOCK WASHER M10	60026100196~ 60026100301~	2
24	1021030	BOLT, HEX HEAD, M10 \times 30		2

SCRUB HEAD GROUP

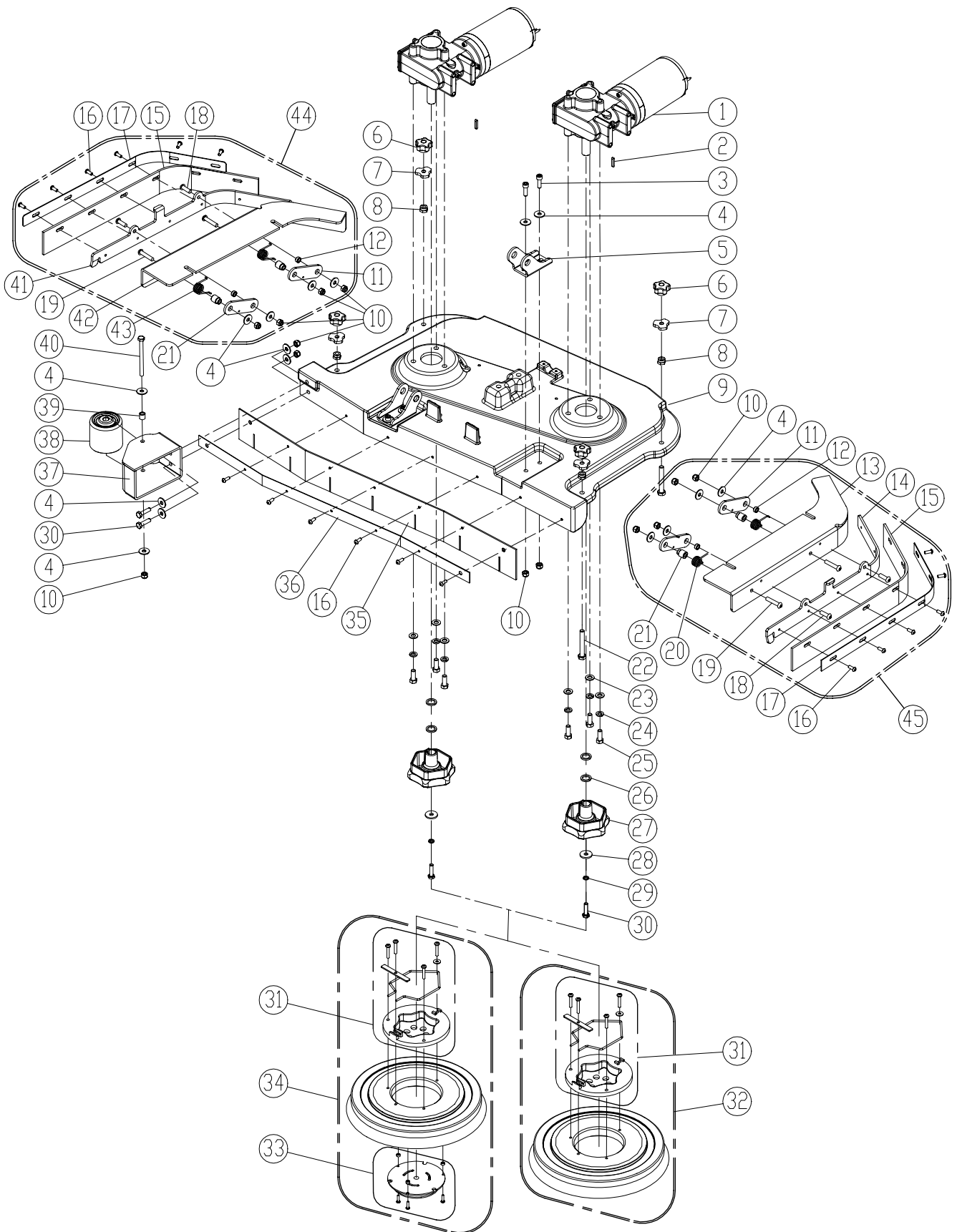

SCRUB HEAD GROUP

DIA NO.	PART NUMBER	DESCRIPTION	SERIAL NUMBER	NO REQ'D
1	8320309	BRUSH MOTOR, 24VDC 350W, KIT	60309100157~	2
2	1655025	KEY, 5x5x25		2
3	1021825	BOLT, HEX HEAD, M8x25		4
4	1421824	FLAT WASHER, M8x ϕ 24x2.0		18
5	8320307	BRACKET, SCRUB HEAD		2
6	8210532	KNOB, M10		4
7	8340516	KNOB M10		4
8	1113012	LOCK NUT, M10		4
9	8321301	SCRUB HEAD HOUSING, RS26+		1
	8320301	SCRUB HEAD HOUSING, RS32+		1
10	1123810	LOCK NUT, M8		15
11	8320355	LEVER		4
12	8320358	SLEEVE		4
13	8320351	LEFT BRACKET		1
14	8320352	BRACKET, LEFT SIDE SKIRT		1
15	8320354	BLADE, SIDE SKIRT, LINATEX		2
16	1514616	SCREW, SOCKET HEAD, M6x16		18
17	8320353	CLAMP, SIDE SKIRT		2
18	1512820	BOLT, SOCKET HEAD, M8x20		4
19	1512840	BOLT, SOCKET HEAD, M8x40		4
20	8320357	TORSION SPRING, LEFT ROTATED		2
21	8320356	SLEEVE		4
22	1021080	BOLT, HEX HEAD, M10X80		4
23	1421020	FLAT WASHER, M10x ϕ 20x2.0		6
24	1422010	LOCK WASHER, 3/8		6
25	1023010	BOLT, HEX HEAD, 3/8-16x1		6
26	8210804	SPACER		4
27	8210805	HUB, BRUSH DRIVER		2
28	1421828	FLAT WASHER, M8x ϕ 28x3.0		2
29	1422821	LOCK WASHER, M8		2
30	1021830	BOLT, HEX HEAD, M8x30		4
31	9000004	CLUCH, G-400S		2
32	9050013	BRUSH, 13 INCH, RS26+		2
	9050016	BRUSH, 16 INCH, RS32+		2
33	9000003	CENTER LOCK, #3		2
34	9040013	PAD DRIVER, 13 INCH, RS26+		2
	9040016	PAD DRIVER, 16 INCH, RS32+		2
35	8321302	FRONT SKIRT, RS26+		1
	8320302	FRONT SKIRT, RS32+		1
36	8321303	FRONT SKIRT CLAMP, RS26+		1
	8320303	RS32+ FRONT SKIRT CLAMP		1
37	8320305	BRACKET, BUMPER WHEEL		1
38	8310362	BUMPER WHEEL		1
39	8115404	SLEEVE, ϕ 8x ϕ 12.7x12.7		6
40	1022800	BOLT, HEX HEAD, M8x100		1
41	8320362	BRACKET, RIGHT SIDE SKIRT		1
42	8320361	RIGHT BRACKET		1
43	8320363	TORSION SPRING, RIGHT ROTATED		2
44	8320360	RIGHT SIDE SKIRT ASSEMBLY		1
45	8320350	LEFT SIDE SKIRT ASSEMBLY		1

SQUEEGEE GROUP

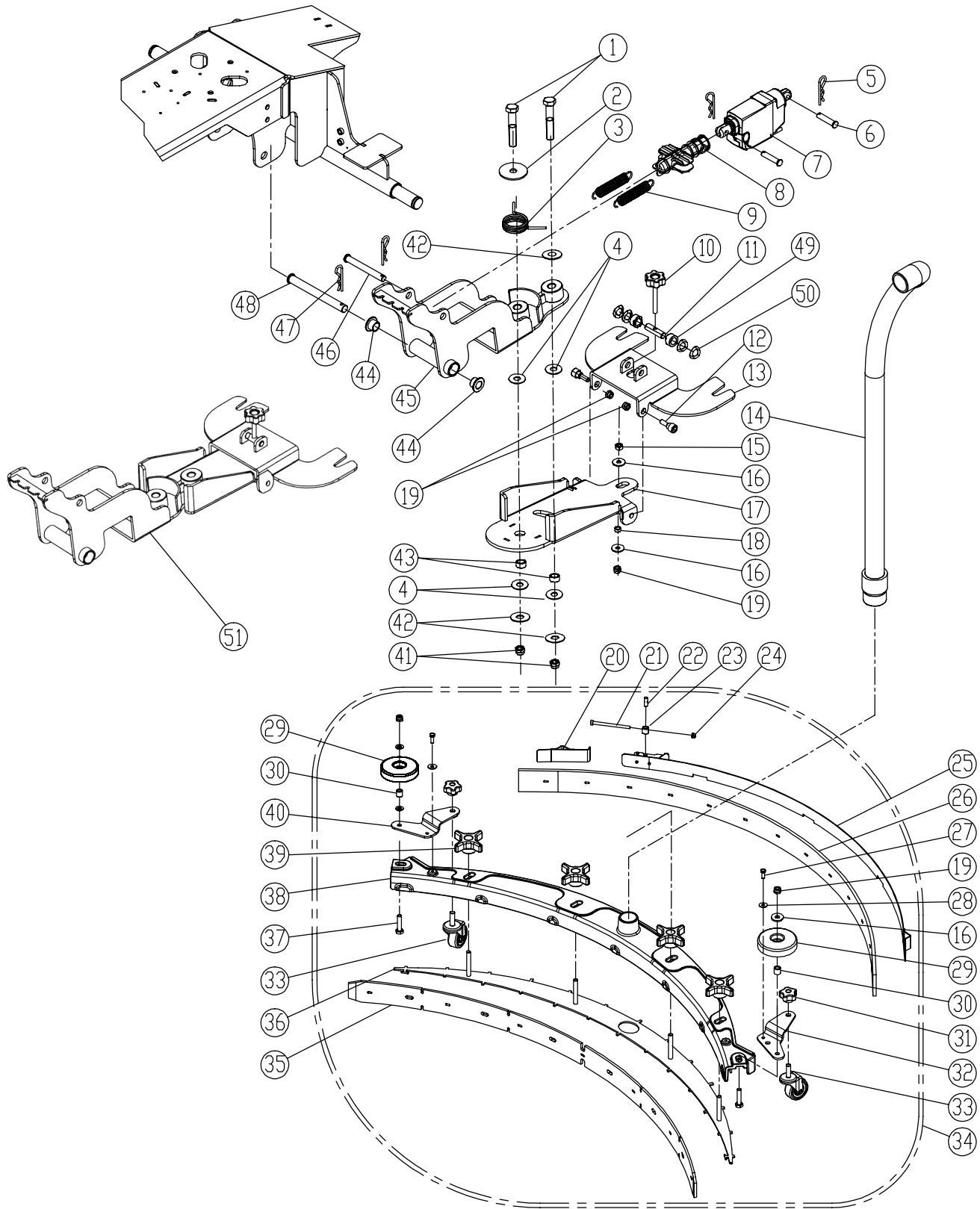

SQUEEGEE GROUP

DIA NO.	PART NUMBER	DESCRIPTION	SERIAL NUMBER	NO REQ'D
1	1021265	BOLT, HEX HEAD, M12×65		2
2	8310314	FLAT WASHER, M13×φ55×3		1
3	8320503	TORSION SPRING		1
4	8321516	PLASTIC WASHER φ 16.2× φ 30×1.5		4
5	8310320	PIN, COTTER		2
6	8310506	PIN, φ10×45		2
7	8320501	LINEAR, ACTUATOR		1
8	8310507	ADAPTER		1
9	8321513	EXTENSION SPRING		2
10	8701002	KNOB M8×70		1
11	8211506	SHAFT		1
12	8211504	SHOULDER BOLT		2
13	8321503	BRACKET, SQUEEGEE INSTALL		1
14	8310270	VACUUM HOSE		1
15	1123807	HEX NUT, M8		1
16	1421824	FLAT WASHER, M8×φ24×2.0		6
17	8321511	BRACKET, SQUEEGEE SWING		1
18	8211508	BUSHING		1
19	1123810	LOCK NUT M8		5
20	8210525	SHORT CLAMP ASSEMBLY		1
21	1221575	SCREW, PAN HEAD, M5×75		1
22	8118624	SHAFT		1
23	8118623	SPACER		1
24	1123507	LOCK NUT, M5		1
25	8311514	CLAMP ASSEMBLY, RS26+		1
	8310514	CLAMP ASSEMBLY, RS32+		1
26	8311531	REAR BLADE, LINATEX, RS26+		1
	8310531	REAR BLADE, LINATEX, RS32+		1
	8311541	REAR BLADE, PU, RS26+, OPTION		1
	8310541	REAR BLADE, PU, RS32+, OPTION		1
27	1021616	BOLT, HEX HEAD, M6×16		2
28	1421612	FLAT WASHER, M6×φ12×1.6		2
29	8116009	PROTECTIVE WHEEL		2
30	8115404	SLEEVE, φ8×φ12.7×12.7		2

SQUEEGEE GROUP

DIA NO.	PART NUMBER	DESCRIPTION	SERIAL NUMBER	NO REQ'D
31	8210532	KNOB, M10		2
32	8118200	LEFT BRACKET		1
33	8310550	CASTER, 2 INCH		2
34	8311570	SQUEEGEE ASSEMBLY, RS26+		1
	8310580	SQUEEGEE ASSEMBLY, RS32+		1
35	8311534	FRONT BLADE, LINATEX, RS26+		1
	8310534	FRONT BLADE, LINATEX, RS32+		1
	8311544	FRONT BLADE, PU, RS26+, OPTION		1
	8310544	FRONT BLADE, PU, RS32+, OPTION		1
36	8311562	RETAINER, SQUEEGEE, RS26+		1
	8310562	RETAINER, SQUEEGEE, RS32+		1
37	1021835	BOLT, HEX HEAD, M8x35		2
38	8311561	SQUEEGEE HOSING, RS26+		1
	8310561	SQUEEGEE HOSING, RS32+		1
39	8210518	KNOB, M8		4
40	8118300	RIGHT BRACKET		1
41	1123115	LOCK NUT, M12		2
42	1421132	FLAT WASHER ϕ 13x ϕ 32x1.5		3
43	8321514	SLEEVE, ϕ 12x ϕ 16x8.5		2
44	8320507	BUSHING		2
45	8321512	BRACKET, SQUEEGEE		1
46	8310508	PIN, ϕ 12x100		1
47	8210309	PIN, COTTER		2
48	8310311	PIN, ϕ 16x150		1
49	8118085	BUSHING		2
50	1435013	WAVE WASHER ϕ 13x ϕ 24x0.5mm		4
51	8321510	SQUEEGEE BRACKET KIT		1

SOLUTION & DETERGENT SYSTEM

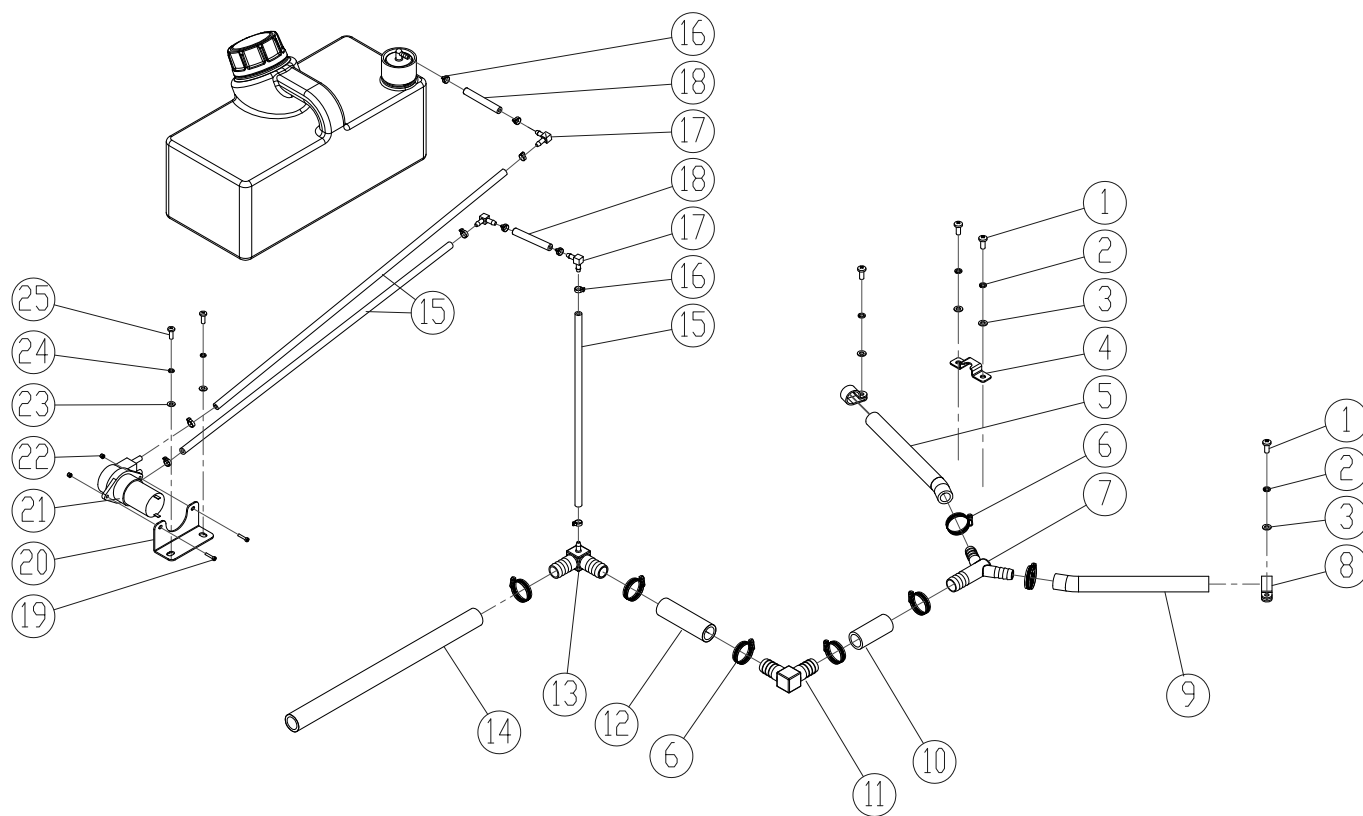

SOLUTION & DETERGENT SYSTEM

DIA NO.	PART NUMBER	DESCRIPTION	SERIAL NUMBER	NO REQ'D
1	1221512	SCREW, PAN HEAD, M5x12		4
2	1422513	SPRING LOCK WASHER, M5		4
3	1421510	FLAT WASHER, M5.3x ϕ 10x1.0		4
4	8320306	CLAMP		1
5	8310903	TUBING, ID=12MM, L=175MM		1
6	1962025	CLAMP, 16-25MM		8
7	8310374	FITTING, PLASTIC		1
8	8146305	PLASTIC CLAMP		2
9	8310904	TUBING, ID=12MM L=210MM		1
10	8310902	TUBING, ID=16MM L=40MM		1
11	8310376	ELBOW		1
12	8310911	TUBING, ID=16MM L=80MM		1
13	8310375	ELBOW WITH CONNECTOR		1
14	8310901	TUBING, ID=16MM L=500MM		1
15	8310905	TUBING, ID=4MM L=330MM		3
16	1914080	TIE, 3x80MM		10
17	8310467	FITTING		3
18	8310910	TUBING, ID=4MM L=100MM		2
19	1221310	SCREW, PAN HEAD, M3x10		2
20	8320911	BRACKET, PUMP		1
21	8320910K	DETERGENT PUMP, KIT		1
22	1123305	LOCK NUT M3		2
23	1421409	FLAT WASHER, M4x ϕ 9x0.8		2
24	1422411	LOCK WASHER, M4		2
25	1221412	SCREW, PAN HEAD, M4x12		2

WEAR AND TEAR PARTS

DIA NO.	PART NUMBER	DESCRIPTION	NO REQ'D
1	8310119	10" WHEEL, PU TIRE	2
2	8116009	PROTECTIVE WHEEL	2
3	8310362	PROTECTIVE WHEEL	1
4	8311531	REAR BLADE, LINATEX, RS26+	1
	8310531	REAR BLADE, LINATEX, RS32+	1
5	8311534	FRONT BLADE, LINATEX, RS26+	1
	8310534	FRONT BLADE, LINATEX, RS32+	1
6	9050013	BRUSH, 13 INCH, RS26+	2
	9050016	BRUSH, 16 INCH, RS32+	2
7	9040013	PAD DRIVER, 13 INCH, RS26+	2
	9040016	PAD DRIVER, 16 INCH, RS32+	2
8	8320130	WATER FILLING HOSE	1



CONNECTOR DIAGRAM

DIA NO.	PART NUMBER	DESCRIPTION	NO REQ'D
1	1883036	CLIP FOR CONNECTOR HOUSING	2
2	1883041	RUBBER GROMMENT	4
3	1883039	FEMALE PIN	2
4	1883037	CONNECTOR HOUSING	1
5	1883038	CONNECTOR HOUSING	1
6	1883040	MALE PIN	2

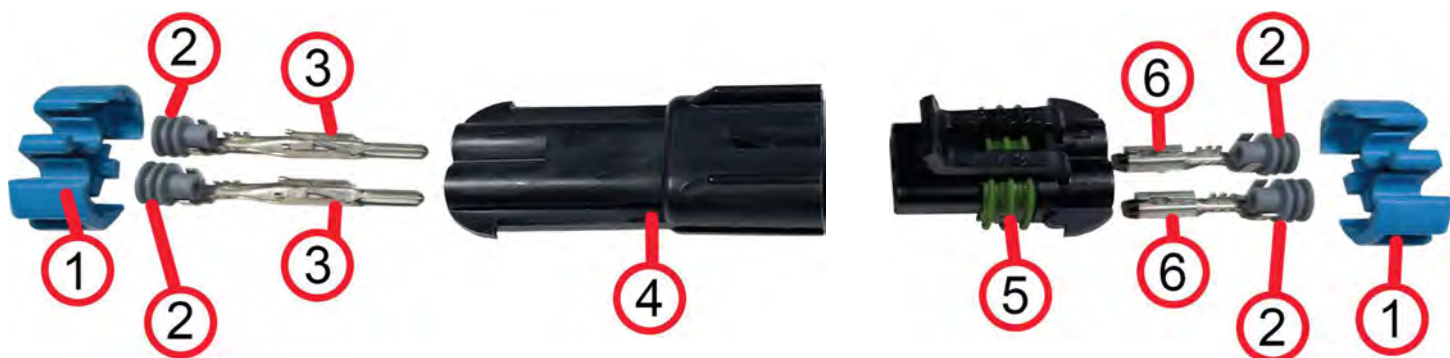

CONNECTOR DIAGRAM

DIA NO.	PART NUMBER	DESCRIPTION	NO REQ'D
1	1883072	CLIP FOR CONNECTOR HOUSING	2
2	1883062	RUBBER GROMMENT	4
3	1883073	MALE PIN	2
4	1883071	CONNECTOR HOUSING	1
5	1883078	CONNECTOR HOUSING	1
6	1883079	FEMALE PIN	2



CONNECTOR DIAGRAM

DIA NO.	PART NUMBER	DESCRIPTION	NO REQ'D
1	1883046	CLIP FOR CONNECTOR HOUSING	2
2	1883052	FEMALE PIN	2
3	1883044	CONNECTOR HOUSING	1
4	1883045	CONNECTOR HOUSING	1
5	1883043	MALE PIN	2

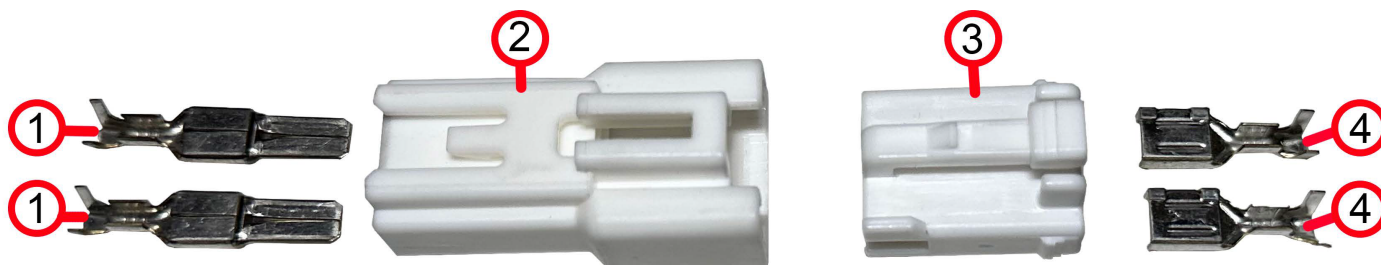

CONNECTOR DIAGRAM

DIA NO.	PART NUMBER	DESCRIPTION	NO REQ'D
1	1883014	MALE PIN	2
2	1883012	CONNECTOR HOUSING	2
3	1883013	CONNECTOR HOUSING	1
4	1883015	FEMALE PIN	1

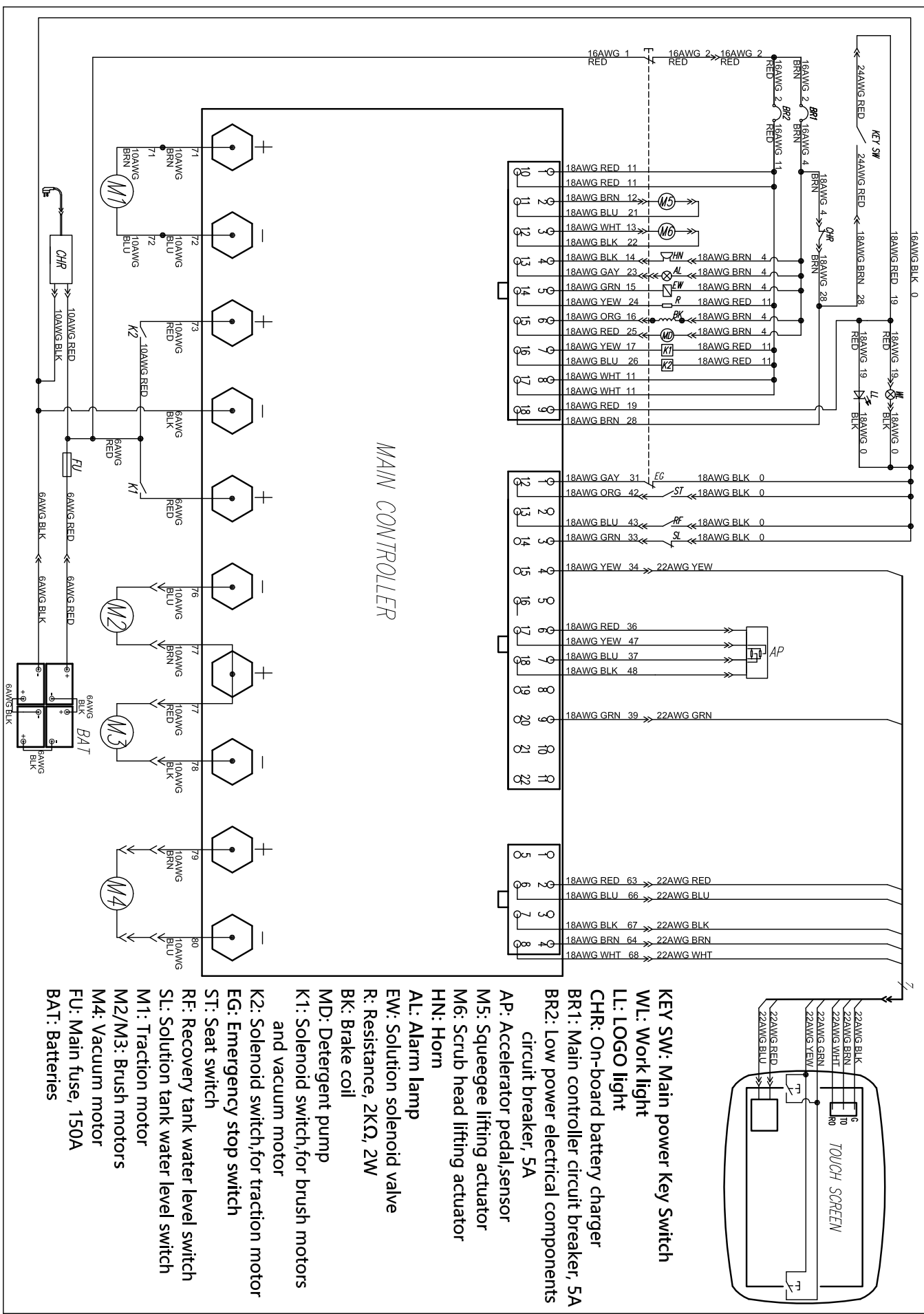

MAIN CONTROLLER

- KEY SW: Main power Key Switch
- WL: Work light
- LL: LOGO light
- CHR: On-board battery charger
- BR1: Main controller circuit breaker, 5A
- BR2: Low power electrical components circuit breaker, 5A
- AP: Accelerator pedal, sensor
- M5: Squeegee lifting actuator
- M6: Scrub head lifting actuator
- HN: Horn
- AL: Alarm lamp
- EW: Solution solenoid valve
- R: Resistance, 2KΩ, 2W
- BK: Brake coil
- MD: Detergent pump
- K1: Solenoid switch for brush motors and vacuum motor
- K2: Solenoid switch for traction motor
- EG: Emergency stop switch
- ST: Seat switch
- RF: Recovery tank water level switch
- SL: Solution tank water level switch
- M1: Traction motor
- M2/M3: Brush motors
- M4: Vacuum motor
- FU: Main fuse, 150A
- BAT: Batteries

