

ICE USA

A DIVISION OF ICE ROBOTICS

www.ice4usa.com



Operator & Parts Manual

Floor Burnisher



iB2000

5015012
REV.01(08-2016)



READ OPERATOR MANUAL CAREFULLY

IMPORTANT: To ensure full warranty protection, Please fill out & return your warranty card.

Please fill out at time of installation for future reference.

Model No. _____

Serial No. _____

Machine Options _____

Sales Rep. _____

Sales Rep. phone no. _____

Customer ID Number _____

Installation Date _____

HOW TO ORDER PARTS

Only use ICE Company supplied or equivalent parts. Parts and supplies may be ordered online, by phone, by fax or by mail.

1. Identify the machine model.
2. Identify the machine serial number from the data label.
3. Ensure the proper serial number is used from the parts list.
4. Identify the part number and quantity.

Do not order by page or reference numbers.

5. Provide your name, company name, customer ID number, billing and shipping address, phone number and purchase order number.



PROTECT THE ENVIRONMENT

Please dispose of packaging materials, old machine components such as batteries, hazardous fluids, including antifreeze and oil, in an environmentally safe way according to local waste disposal regulations. Always remember to recycle.



International Cleaning Equipment
XiangShi Road LiaoBu DongGuan GuangDong China
Tel: 0769-8186 9000
Fax: 0769-8186 3000

Specifications and parts are subject to change without notice.

TABLE OF CONTENTS

SAFETY PRECAUTIONS	4
MACHINE COMPONENTS	5
MACHINE OPERATING INSTRUCTIONS	6
MACHINE MAINTENANCE & STORAGE	7
PARTS LIST	8-13
WEAR & TEAR PARTS	14
SPECIFICATIONS	14
WIRING DIAGRAM	15

SAFETY PRECAUTIONS



Carefully read and understand this manual before operating this machine.
This machine must be grounded!

This floor/finishing machine shall be grounded while in use to protect the operator from electric shock. Grounding provides a path of least resistance for electric current. This machine is equipped with a cord having an equipment-grounding conductor and grounding plug. The plug must be plugged into an appropriate outlet that is properly installed and grounded in accordance with all local codes and ordinances. Do not remove the ground pin under any circumstances.

This machine is for use on a nominal 120-volt circuit and has a grounding plug that resembles the plug illustrated in Figure. Make sure that the machine is connected to an outlet having the same configuration as the plug. No adapter should be used with this machine.

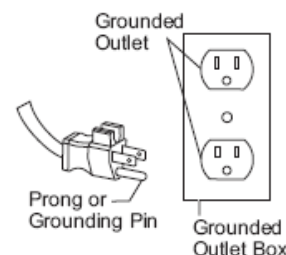

This machine is intended for commercial use. It is constructed for use in an indoor environment and is not intended for any other use. Use only recommended accessories.

1. Do not operate machine:

- Unless trained and authorized.
- In flammable or explosive areas.
- With a damaged cord or plug.
- If not in proper operating condition.
- Without bag / filters in place.
- Unless you have read and understand the operators manual.
- With the use of extension cords.
- In outdoor areas and standing water.

2. Before operating machine:

- Make sure all safety devices are in place and operating properly.

3. When using machine:

- Only use approved burnishing pads.
- Do not pull machine by cord or plug.
- Do not stretch cord.
- Ensure the dust collection bag is in place and is tightly sealed to the machine.
- Turn power switch to “off “ prior to unplugging machine.
- Report machine damage or faulty operation immediately.
- Do not run machine over cord.
- Do not pull cord around sharp edges or corner.
- Do not unplug by pulling on the cord.
- Do not handle plug with wet hands.
- Keep cord away from heated surfaces.
- Do not pick up burning or smoking debris such as cigarettes, matches or hot ashes.

4. Before leaving or servicing machine:

- Turn off machine.
- Unplug cord from outlet.

5. When servicing machine:

- Unplug cord from outlet.
- Use manufacturer supplied or approved replacement parts.



To avoid electrical shock, please replace the power cord immediately if any damage is being detected. The replacement must be performed only by an authorized person or by our customer service center.

MACHINE COMPONENTS

Machine Description

- New structure design
- 20" Housing
- 20" Pad brush
- Engineering plastics
- Drive belt
- Handle foldable structure
- Safety lock-out switch
- Security protection in an upright
- Use twist spring adjustment pad pressure
- 50' Cord

Machine Structure

- | | |
|---------------------------|--------------------|
| 1. Brush assy | 2. Housing |
| 3. Wheel | 4. Foldable handle |
| 5. Safety lock-out switch | 6. Trigger |
| 7. Leveling rod | 8. Handle |
| 9. Motor cover | 10. Cover dust bag |
| 11. Twist spring | 12. Lock washer |
| 13. Pad holder 20" | |

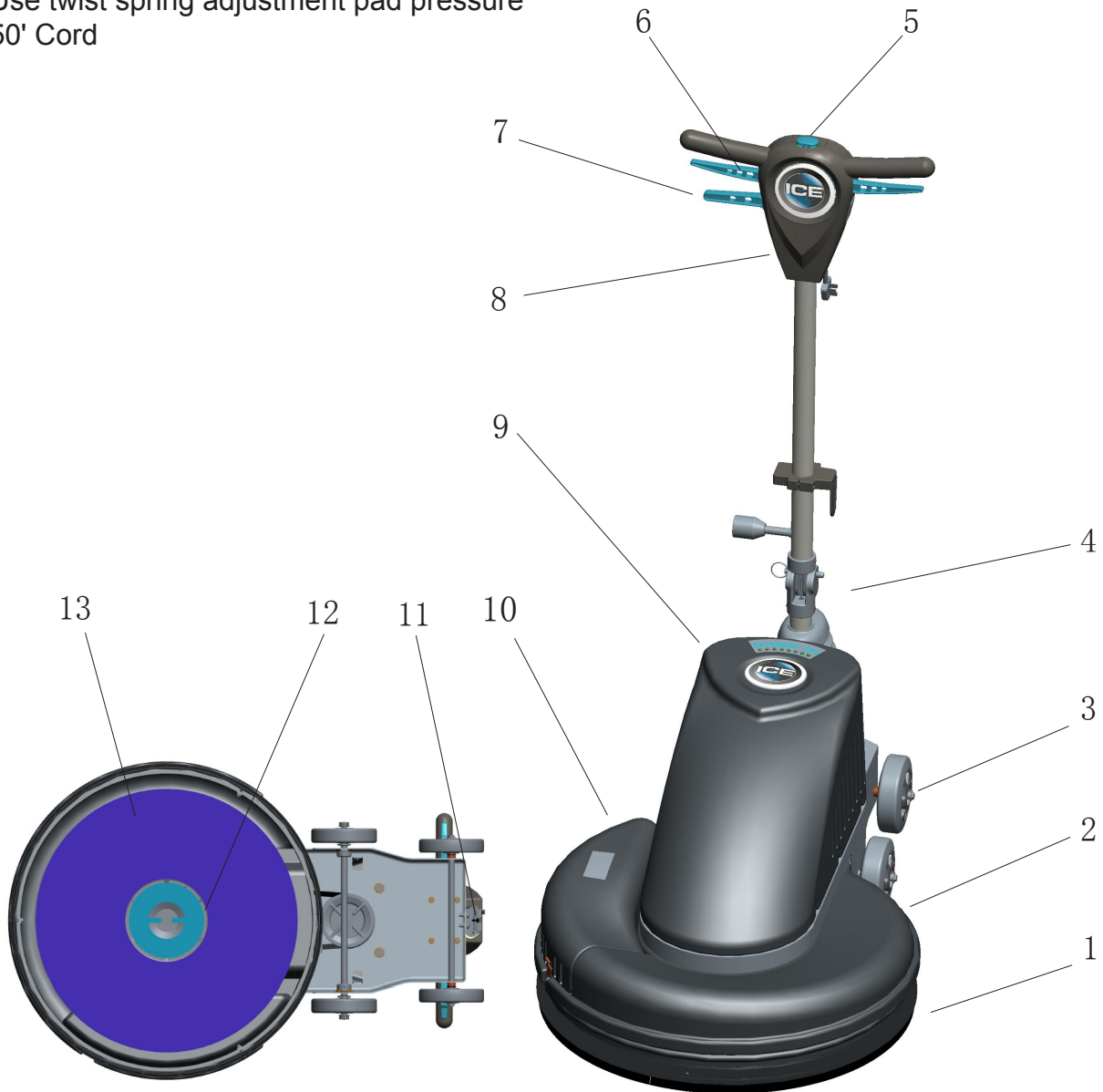

OPERATION OF HIGH SPEED FLOOR MACHINE



THIS IS A SPECIALIZED MACHINE WHICH REQUIRES THE OPERATOR TO UTILIZE A ICE APPROVED PAD, AND MUST BE ADJUSTED PROPERLY TO ENSURE THE HIGHEST POSSIBLE PERFORMANCE AND PRODUCTIVITY.



Read operators manual thoroughly prior to operating or servicing this machine.

General Use:

- 1) Remove any obstructions or other obstacles in the area which is to be cleaned.
- 2) Remove dust recovery bag and empty it out in a trash receptacle. Replace dust recovery bag on machine, ensuring it is sealed tightly to the machine.
- 3) Place handle in upright position and tilt machine back until handle rests on the floor.



Be sure the machine is not plugged into an outlet.

- 4) Remove the pad center gripping device by unscrewing the thumbscrews.
- 5) Place a "ICE approved" burnishing pad on the pad driver and re-attach the center gripping device. (check with your ICE distributor for approved pads)
- 6) Place machine back into its upright position.
- 7) Plug power cord into grounded outlet.



Do not use an extension cord in conjunction with the standard power cord.

- 8) Adjust the handle (switch housing) height to a comfortable operating position.
- 9) To start the machine, push on the Blue safety button of the top of upper switch housing and squeeze either of the switch levers.
- 10) When the machine is in operation, both hands should be placed on the handle (switch housing).
- 11) Once the machine has reached operating speed, look at the digital pad pressure meter located on the top of the motor cover. There are 3 light colors which will help you determine optimal pad pressure for operating the machine. **YELLOW LIGHT(left):** If one yellow light is illuminated, adjustment front wheels position(forward) to increase the pad pressure. **RED LIGHT(right):** If one or both red lights are illuminated, adjustment front wheels position(backward) to reduce the pad pressure. If above two situations can not change, please replace the twist spring. **GREEN LIGHT(S):** If one, two, three, four or five green lights are illuminated, the machine is running at the optimal pad pressure and you may begin working.
- 12) When the machine is in operating, both hands should be gripping the hand.
- 13) To stop the machine at any time, simply release the switch lever, and the machine will stop automatically.



MAINTENANCE

To keep the machine performing well for many years, please follow the following maintenance procedures.



Always confirm that the machine is unplugged prior to performing any maintenance or repairs.

1. Unplug machine as soon as you are done using it.
2. Remove dust recovery bag and empty contents into a trash receptacle. inspect dust recovery bag for any damage prior to replacing it on the machine.
3. Clean the outside of the machine with a mild cleaner.
4. Check power cord for any damage. If any damage is detected, replace the cord immediately.
5. Lubricate wheels with a water resistant lubricant once a month.
6. Check machine for loose or missing nuts and bolts, and replace as necessary.
7. If the machine is used in a dusty environment, you may remove the motor cover and blow the motor clean with compressed air. This will allow for good ventilation and help the motor run cooler.



The motor is computer controlled, and utilizes computer circuitry. Do not allow this circuitry to get wet! Never store a low speed machine with the pad driver or brush mounted

STORAGE

- 1) Unplug machine from power source and wrap cord on handle.
- 2) Store in upright position in a dry area.

iB2000 HANDLE ASSEMBLY

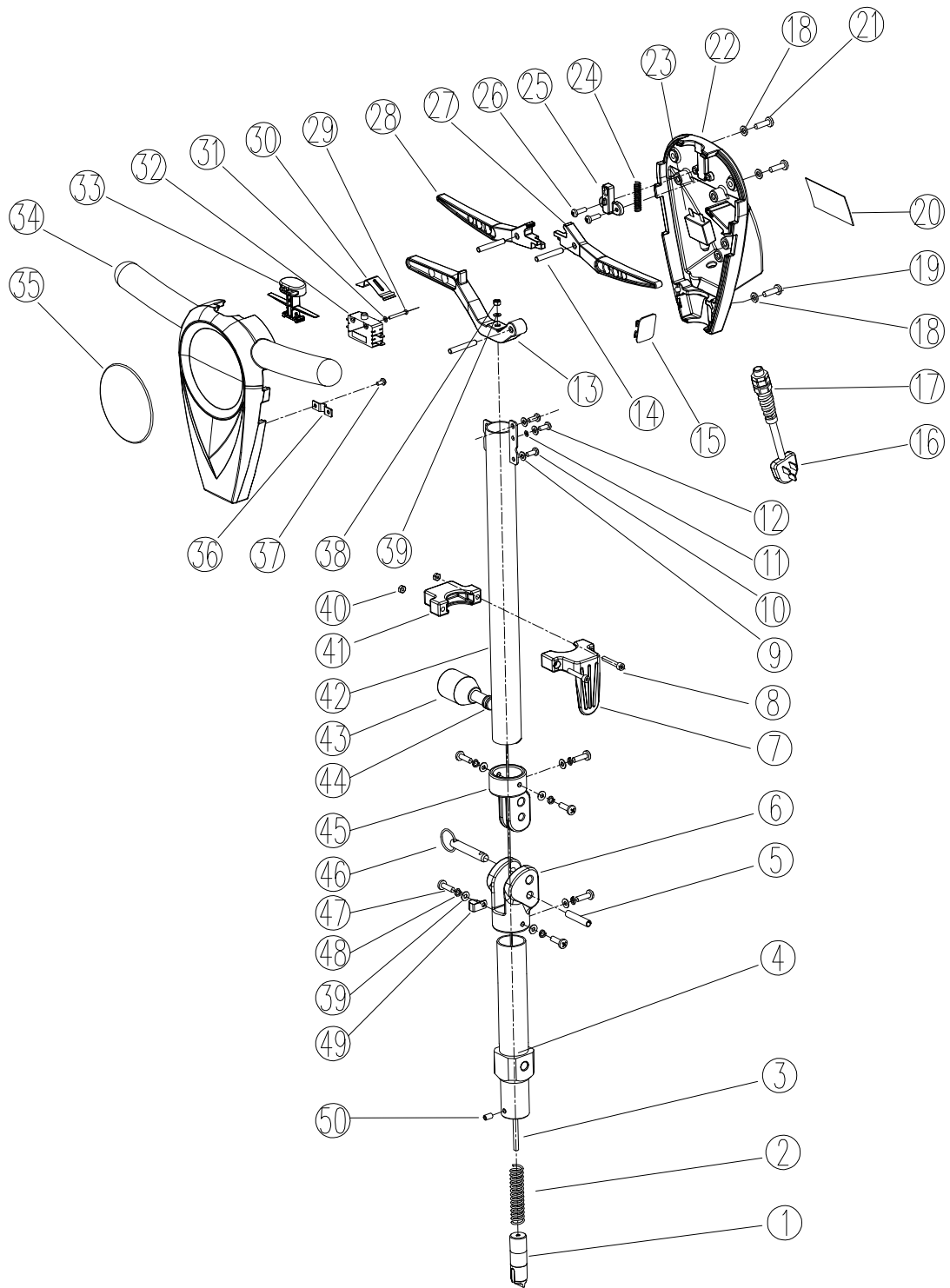

HANDLE ASSEMBLY PARTS LIST

DIA NO	PART NUMBER	DESCRIPTION	NO REQ'D
1	5020112	INSERT	1
2	4010208	SPRING LEVELING	1
3	5020120	ROD LEVELING	1
4	5020109	TUBING BOTTOM BRACKET	1
5	1647845	PIN	1
6	5011019	TUBING BOTTON BASE	1
7	4010405	HOOK CABLE	1
8	1511540	SCREW M5 X 40 HEX SOCKET	2
9	1434500	TOOTH WASHER $\Phi 5$	4
10	1211512	SCREW M5X12	4
11	1434400	TOOTH WASHER $\Phi 4$	2
12	1221412	SCREW M4X12	1
13	5011017	LEVELING ROD	1
14	4010314	PIN	3
15	5011004	COVER	1
16	4010320	CORD POWER SUPPLY	1
17	4020310	STRAIN RELIEF CORD	1
18	1421616	WASHER PLAIN $\Phi 6$	4
19	1512635	SCREW M6 X 35	2
20	5015001U	SERIAL NUMBER	1
21	1512625	SCREW M6 X 25	2
22	4010312	REAR COVER	1
23	5013009	CIRCUIT BREAKER 20A	1
24	4010333	SPRING SAFETY	1
25	4010317	BALL BASE	1
26	1211408	SCREW M4X8	2
27	4010330	LEFT TRIGGER SWITCH	1
28	4010331	RIGHT TRIGGER SWITCH	1
29	1211325	SCREW M3X25	2
30	4010323	SPRING SWITCH	1
31	1434300	TOOTH WASHER	2
32	4010308	SWITCH	1
33	4010307	SAFETY BOTTOM	1
34	4010301	FRONT COVER	1
35	4010316	ICE LOGO	1
36	4010311	CLAMP CORE	1

HANDLE ASSEMBLY PARTS LIST

DIA NO	PART NUMBER	DESCRIPTION	NO REQ'D
37	1221406	SCREW M4X6	2
38	1123608	NUT LOCK M6	1
39	1421612	WASHER Ø6	6
40	1113507	NUTLOCKM5	2
41	4010403	CLAMP HOOK	1
42	5020119	TUBING TOP BRACKET	1
43	4010215	CORD HANDLE	1
44	4010213	GROMMET	1
45	5011018	TUBING TOP BASE	1
46	1644045	PIN	1
47	1221620	SCREW M6X20	6
48	1422616	WASHER LOCK Φ6	6
49	6150712	WIRE CLIP	1
50	1535610	SCREW M6x10	1

IB2000 BASE ASSEMBLY

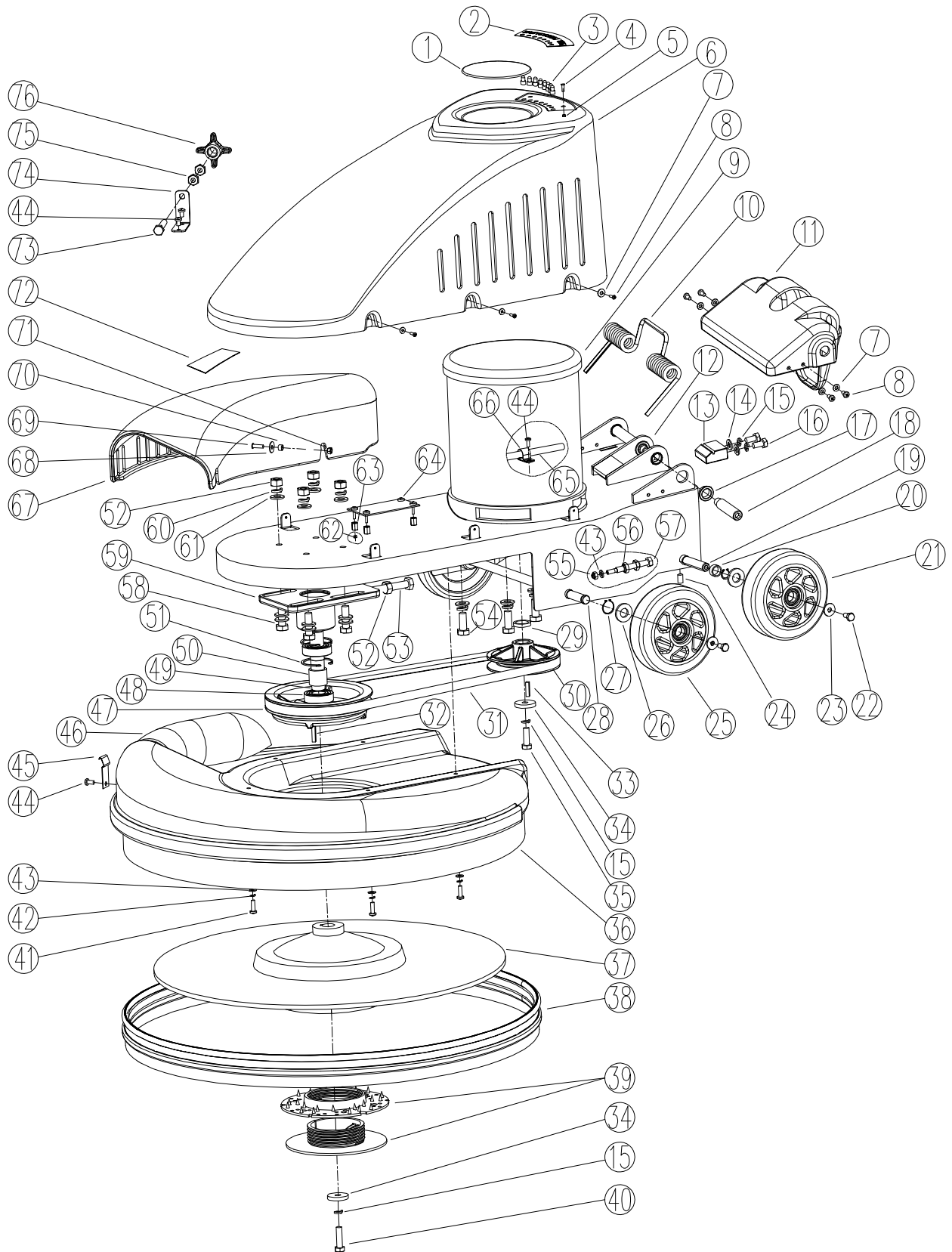

BASE ASSEMBLY PARTS LIST

DIA NO	PART NUMBER	DESCRIPTION	NO REQ'D
1	4010316	ICE LOGO	1
2	5015006	BRUSH ADJUSTMENT DECAL	1
3	5013010U	PCB ASSEMBLY120V	1
4	1222416	SCREW M4x16	2
5	1123406	NUT LOCK M4	4
6	5012414	COVER MOTOR	1
7	1421409	WASHER PLAIN $\Phi 4 \times \Phi 9 \times 0.8$	14
8	1221410	SCREW M4x10 PH	10
9	5012304U	MOTOR 1.5KW 120v	1
	5012310-1	CARBON BRUSH ASSEMBLY	1
	6210423	RECTIFIER 50A/1000V	1
10	5020108	TWIST SPRING	1
11	5020117	TWIST SPRING COVER	1
12	5020100	HOUSING	1
13	5020113	POSITION PLATE	1
14	1421816	WASHER PLAIN $\Phi 8 \times \Phi 16 \times 1$	2
15	1422821	WASHERLOCK $\Phi 8$	4
16	1021816	SCREW M8x16 HEX	2
17	5020106	SPACER	4
18	5020107	SCREW ROD	2
19	5012407	REAR AXLE	1
20	5012408	SPACER WHEEL AXLE	2
21	4210115	WHEEL 6"	2
22	4010111	HEX SCREW M6x12.7	4
23	1421618	WASHER PLAIN $\Phi 6.4 \times \Phi 18 \times 1.6$	4
24	1534608	SCREW M6x8	2
25	4210116	WHEEL 5"	2
26	1421625	WASHER PLAIN $\Phi 12.5 \times \Phi 25 \times 1.5$	4
27	1436012	RETAINING RING EXTERNAL $\Phi 12$	4
28	5012426	FRONT AXLE	1
29	5012305	SPACER	1
30	5012308	DRIVING PULLEY	1
31	5012603	VEE BELT	1
32	5012205	KEY DRIVEN SHAFT	1
33	5012306	KEY MOTOR	1
34	5012303	WASHER PLAIN $\Phi 8 \times \Phi 30 \times 5$	2
35	1021825	SCREW M8x25 HEX	1
36	5012101	HOUSING	1
37	9060020	PAD HOLDER 20"	1
38	5012112	FLEXIBLE SKIRT	1

BASE ASSEMBLY PARTS LIST

DIA NO	PART NUMBER	DESCRIPTION	NO REQ'D
39	9000001	BIG MOUTH	1
40	1031830	SCREW M8x30 HEX	1
41	1521620	SCREW M6 X 20 HEX SOCKET	7
42	1422616	WASHER LOCK $\Phi 6$	7
43	1421612	WASHER PLAIN $\Phi 6 \times \Phi 12 \times 1.6$	9
44	1221512	SCREW M5X12	4
45	5012106	HOOK COVER DUST BAG	1
46	5012105	DUST COLLECTOR BAG	1
47	5012201	DRIVEN PULLEY	1
48	1612607	BEARING 6004LU TPI	2
49	5012203	DRIVEN SHAFT	1
50	5012204	SPACER BEARING	1
51	1437042	RETAINING RING INTERNAL $\Phi 42$	2
52	1111008	NUT M10	5
53	1021065	SCREW M10x65 HEX	1
54	1011016	SCREW M10x16 HEX	4
55	1123608	NUT LOCK M6	1
56	1111807	NUT M8	4
57	5012423	SCREW ROD M8	2
58	1031032	SCREW M10x32 HEX	4
59	5012202	MOUNTING PLATE DRIVEN SHAFT	1
60	1432026	WASHER LOCK $\Phi 10$	8
61	1421020	WASHER PLAIN $\Phi 10$	16
62	1123305	NUTLOCKM3	4
63	1143315	NUT M3x15	4
64	1221306	SCREW M3X6	4
65	5013004	MOTOR POWER CORD	1
66	6150712	WIRE CLIP	1
67	5012102	COVER DUST BAG	1
68	1421516	WASHER PLAIN $\Phi 5 \times \Phi 16 \times 1$	1
69	1221515	SCREW M5X15	1
70	5014006	SPACER	1
71	1113507	NUTLOCK M5	1
72	5015004	WARNING DECALL	1
73	1031845	SCREW M8x45 HEX	1
74	5012113	COVER DUST BAG BRACKET	1
75	1123810	NUT LOCK M8	2
76	8118003	HANDLE	1

WEAR & TEAR PARTS

DIA NO	PART NUMBER	DESCRIPTION	NO REQ'D
1	4210115	WHEEL 6"	2
2	5012603	VEE BELT	1
3	4210116	WHEEL 5"	2

SPECIFICATIONS

Model	iB2000
Power	1.5HP
Voltage	120 V
Capacity	1.2 L
Working Width	20"(51cm)
Brush Speed	2000 rmp
Cable Length	15 m
Sound Level	62dB(A)
Weight	48.5Kg
Dimension LXWXH	96X62X128 cm

Wiring Diagram iB2000

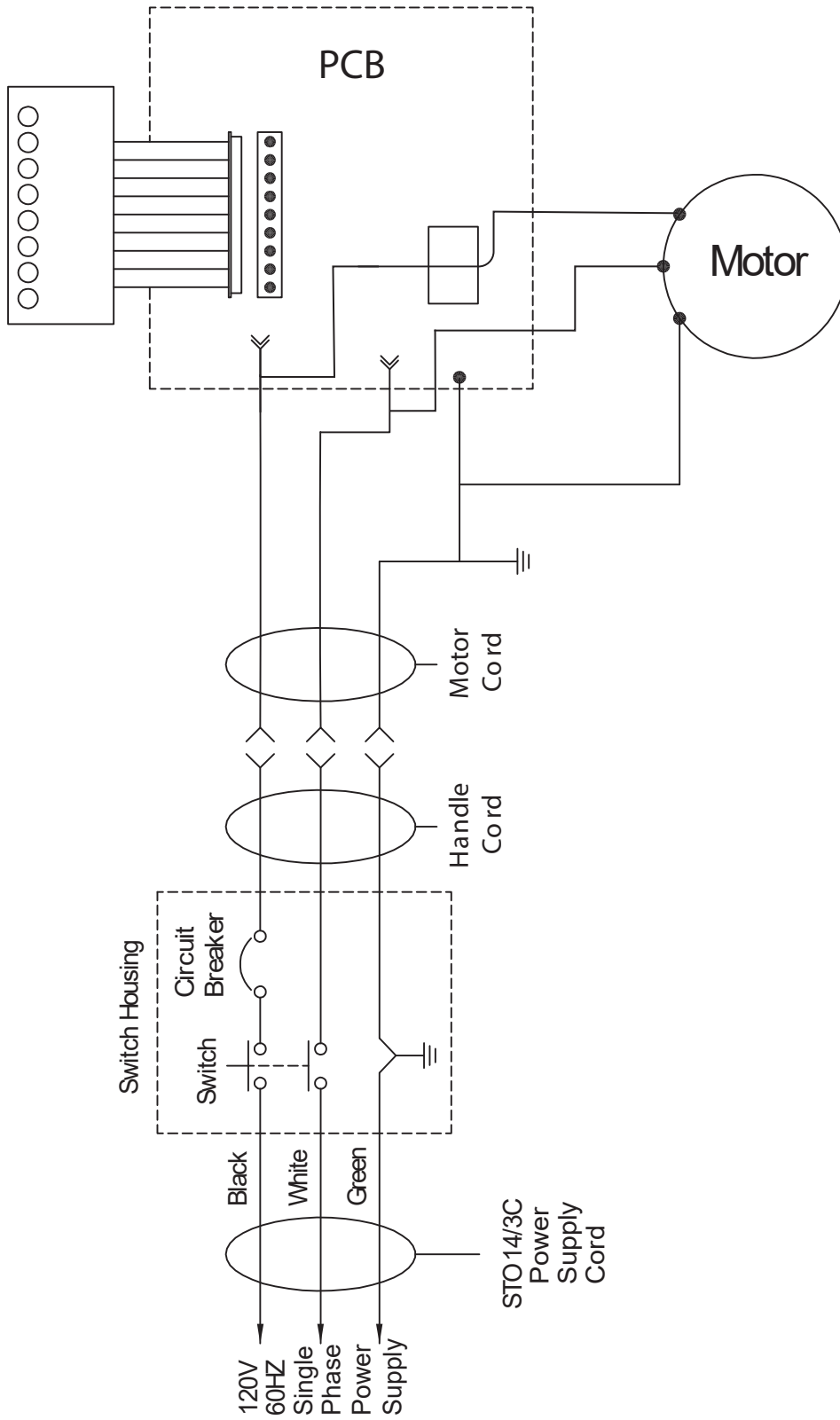

CERTIFICATE OF QUALIFIED

MODEL: _____

SERIAL NO.: _____

INSPECTOR: _____

DATE: _____

INTERNATIONAL CLEANING EQUIPMENT

TEL: (+86) 769 8186 9000

FAX: (+86) 769 8186 3000