



www.icecompanies.com

Operator & Parts Manual

Automatic Scrubber



i36BT
i36BT-CY

8230901
REV.01(01-2020)

INTELLIGENT CLEANING EQUIPMENT



READ OPERATOR MANUAL CAREFULLY!

IMPORTANT: To ensure full warranty protection, please fill out & return your warranty card.

Please fill out at time of installation for future reference.

Model No. _____

Serial No. _____

Machine Options _____

Sales Rep. _____

Sales Rep. Phone No. _____

Customer ID Number _____

Installation Date _____

HOW TO ORDER PARTS

Only use ICE Company supplied or equivalent parts. Parts and supplies may be ordered online, by phone, by fax or by mail.

1. Identify the machine model.
2. Identify the machine serial number from the data label.
3. Ensure the proper serial number is used from the parts list.
4. Identify the part number and quantity.
Do not order by page or reference numbers.
5. Provide your name, company name, customer ID number, billing and shipping address, phone number and purchase order number.



PROTECT THE ENVIRONMENT

Please dispose of packaging materials, old machine components such as batteries, hazardous fluids, including antifreeze and oil, in an environmentally safe way according to local waste disposal regulations.



Always remember to recycle.

ICE Company Limited
XiangShi Road LiaoBu DongGuan GuangDong China
Tel: 0769 - 81850061
Fax: 0769 - 81850001

Specifications and parts are subject to change without notice.

TABLE OF CONTENTS

SAFETY PROCATIONS.....	4
MACHINE COMPONENTS.....	5
MACHINE SETUP & INSTALLATION.....	6
MACHINE OPERATION.....	7
WHILE OPERATING MACHINE.....	7
TANK DRAINING.....	8
BATTERY CHARGING.....	9
PREVENTATIVE MAINTENANCE.....	9
CYLINDRICAL BRUSH MODEL.....	11
CYLINDRICAL ASSEMBLY INSTRUCTIONS.....	12-13
BASIC TROUBLESHOOTING.....	14
TECHNICAL SPECIFICATION.....	15
PARTS LIST.....	16-43
WEAR AND TEAR PARTS.....	44
WIRING DIAGRAM.....	45

SAFETY PRECAUTIONS

This machine is intended for commercial use. It is designed exclusively to scrub hard floors in an indoor environment and is not constructed for any other use. Only use recommended accessories.

All operators shall read, understand and exercise the following safety precautions:

1. Do not operate machine:

- Unless trained and authorized.
- Unless you have read and understand the operators manual.
- In flammable or explosive areas.
- If not in proper operating condition.
- In outdoors areas.

2. Before starting machine:

- Make sure all safety devices are in place and operate properly.

3. When using machine:

- Go slow on inclines and slippery surfaces.
- Follow all safety guidelines.
- Be very careful when using the machine in reverse.
- Reduce speed when turning.
- Report and fix any damage to machine prior to operating it.
- Never allow children to play on or around.
- Do not operate on inclines that exceed 5% (3°).

4. Before leaving or servicing machine:

- Stop on level surface.
- Turn off machine.

5. When servicing machine:

- Read operators manual thoroughly prior to operating or servicing this machine.
- Use manufacturer supplied or approved replacement parts.
- Secure machine with wheel blocks prior to jacking the machine up.
- Use approved jack or hoist to safely elevate the machine.
- Disconnect batteries prior to working on machine.
- Wear gloves when handling batteries or battery cables.

- Avoid any contact with battery acid
- Avoid moving parts. Do not wear loose fitting clothing while servicing machine.

 **WARNING: Batteries emit hydrogen gas. Explosion or fire can result from hydrogen gas. Keep sparks and open flames away! Keep battery compartment open when charging.**

 **WARNING: Flammable materials can cause an explosion or fire. Do not use flammable materials in tanks.**

 **WARNING: Flammable materials or reactive metals can cause explosion or fire. Do not pick up.**

MACHINE COMPONENTS

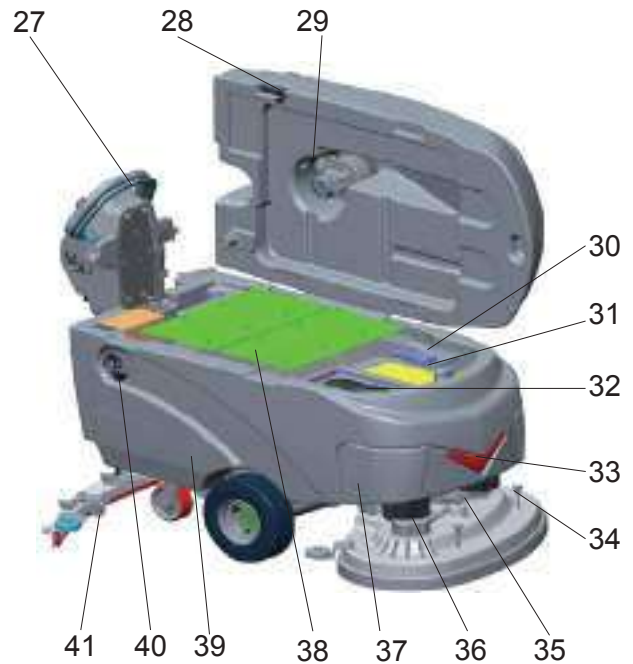
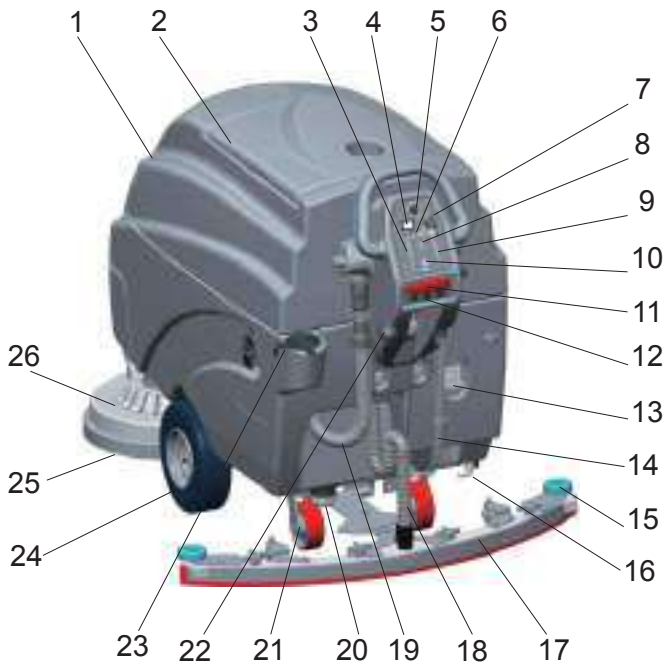

- 1. Recovery Tank
- 2. Recovery Tank Cover
- 3. Brush Pressure Adjusting Buttons & Indicator Light
 - Brush Pressure Increase Button
 - Brush Pressure Decrease Button
- 4. Hour Meter
- 5. Speed Control Knob
 - Slow Speed
 - Fast Speed
- 6. Battery Meter
- 7. Main Power Key Switch
- 8. 1-STEP Scrub Head Up/Down Switch & Indicator Light
- 9. Solution Flow Control Buttons & Indicator Light
 - Solution Flow Increase Button
 - Solution Flow Decrease Button
- 10. Vacuum Motor Switch & Indicator Light
- 11. Emergency Stop Button
- 12. Drive Motor Circuit Breaker
- 13. On-board Charger
- 14. Solution Tank Level / Drain Hose
- 15. Bumper Rollers
- 16. Ball Valve
- 17. Squeegee Assembly

- 18. Squeegee Vacuum Hose
- 19. Recovery Tank Drain Hose
- 20. Filter Assembly
- 21. Caster, 5 Inch
- 22. Squeegee Lift Lever
- 23. Hose Fill-port
- 24. Wheels, 12 Inch
- 25. Scrub Head Skirt
- 26. Disk Scrub Head
- 27. Control Handle Start Bail
 - Direction Decal
- 28. Recovery Tank Support Stand
- 29. Vacuum Motor, 36VDC
- 30. Vacuum Motor Circuit Breaker
- 31. Connector, 175A
- 32. Bucket Fill Port/ Clean-Out Port
- 33. Led Light
- 34. Brush & Pad Release Plunger
- 35. Scrub Head Adjusting Bolt
- 36. Brush Motor, 36VDC
- 37. Front Cover
- 38. Batteries
- 39. Solution Tank
- 40. Logo, ICE
- 41. Caster, 2 Inch, Squeegee

MACHINE SET UP & INSTALLATION

UNCRATING MACHINE

Be sure and check packing carton for any damage. Immediately report any damage to carrier. Check the contents of package to ensure that the following items are included:

- Machine
- 6-6V Batteries
- Squeegee assembly
- 2-Pad Drivers
- 2-Brushes

INSTALLING BATTERIES

The batteries are already in the machine upon delivery; However you will need to connect the cables to the battery posts.

⚠ WARNING: Batteries emit hydrogen gas. Explosion or fire can result from hydrogen gas. Keep sparks and open flames away! Keep battery compartment open when charging.

Recommended Battery spec:
6-6V, 260AH@20HR or 330AH@20HR deep cycle batteries.

Max. batteries dimensions :
590mm (L) X 534mm (W) X 365mm (H)

1. Turn the main power key switch off.
2. Open recovery tank to gain access to battery compartment.
3. Carefully place the batteries into the compartment as shown in figure below. Place the battery brace at the rear of the batteries.

DO NOT DROP BATTERIES INTO COMPARTMENT!

4. Connect battery cables to posts in numbered order as shown in drawing below.
RED to POSITIVE and BLACK to NEGATIVE.

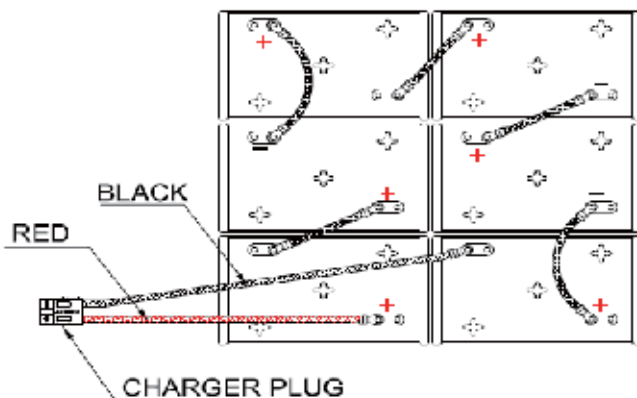

MACHINE SET UP

PRE-OPERATION CHECKS

1. Sweep or dust mop the surface to be cleaned.
2. Check battery meter to make sure batteries are fully charged. (See BATTERY CHARGING)
3. Check that squeegee is properly installed.
4. Check that brushes / pads is properly installed.

INSTALLING BRUSHES OR PADS

1. Turn off the 1-STEP Scrub head up/down switch (see machine components, item #8) and Raise the Scrub head off the floor, then stop machine on the level surface, remove the key and ensure the machine is turned off.
2. If using the Pad Driver, first attach the appropriate pad to the pad driver surface.
3. Align the pad driver or brush under the motor hub and push it upward to engage.



4. To remove the pad driver or brush, raise the scrub head and push the pad release plunger (see machine components, item #34) downward.

MOUNTING THE SQUEEGEE ASSEMBLY

1. Lift the squeegee lift lever (see machine components, item #22) to the upward position.
2. Mount the squeegee assembly to the squeegee pivot bracket. make sure the knobs are completely seated into the slots before securing knobs.
3. Connect the vacuum hose to the squeegee assembly. Loop the hose by using the hose clip provided.
4. Check the squeegee blades for proper adjustment.

FILLING THE SOLUTION TANK

The machine is equipped with a hose fill-port (see machine components, item #23) at the rear of the machine, and a bucket fill-port (see machine components, item #32) located under the recovery tank. Before accessing the bucket fill-port make sure that the recovery tank is empty.

Fill the solution tank to the "110L" level on the solution tank sight gauge. When using the bucket fill-port, stop filling when the level reaches the bottom edge of the fill-port.

NOTE: When filling the solution tank with a bucket, make sure that the bucket is clean. Do not use the same bucket for filling and draining the machine.

 **WARNING: Do not put any flammable materials into solution tank. this can cause an explosion or a fire. Only use recommended cleaning chemicals. Contact your janitorial supply distributor for recommendations on proper chemicals.**

MACHINE OPERATION

 **WARNING: Do not operate machine unless you have read and understand this manual.**

1. Turn the main power key switch(see machine components, item #7) to the on (I) position.
2. Check the battery level meter (see machine components, item #6), if the battery meter is in the red, **DO NOT** continue to operate the machine and recharge the batteries immediately.
3. Turn on the 1-STEP scrub head up/down switch (see machine components, #8) to lower the scrub head to the floor, the 1-STEP switch indicator is light.
4. Lower squeegee assembly to the floor by lowering the squeegee lift lever(see machine components, item #22).
5. Check the solution flow indicator (see machine components, item #9), adjust the solution flow control switch to a desired flow rate.

NOTE: Solution will not begin to flow until the control handle bail is pulled.

6. Turn on the vacuum motor switch(see machine components, item #10).
7. Pull the control handle bail (see machine components, item #27) backwards to start scrubbing .The machine will automatically propel forward. To reverse the machine, simply push the control handle bail forward.
NOTE: Raise squeegee when reversing machine.
8. The scrubbing speed can be adjusted, Adjust the speed control knob (see machine components, item #5) to a desired speed.
NOTE: 45-60 meters (150-200 ft)per minute is the recommended scrubbing speed.
simply press the pressure adjuting button to increase (+) or decrease (-) the brush pressure as needed.(see machine components, item #3)
10. To stop scrubbing, release the control handle bail, turn off the 1-STPE switch to raise the scrub head assembly, raise he squeegee assembly.

WHILE OPERATING MACHINE

 **WARNING: Fire Or Explosion Hazard. Do Not Pick Up Flammable Materials Or Reactive Metals.**

1. Go slow on inclines and slippery surfaces. Do not operate the machine on inclines that exceed 5% (3°).
2. Do not keep the machine in the same position with pad / brush spinning, keep the machine moving to prevent damage to floor finish.
3. If the squeegee assembly leaves streaks on the floor, raise the squeegee off the floor and wipe the blades down with a damp cloth. Pre-sweep the area to prevent leaving streaks on the floor.
4. Pour a recommended defoamer into the recovery tank if excessive foam appears.

 **WARNING: Do not allow foam to enter the float shut-off screen, vacuum motor damage will result. Foam will not activate the float shut-off screen.**

5. Occasionally check the battery level meter(see machine components, item #6). when meter is in the red, stop scrubbing and recharge the batteries.

 **WARNING: When battery meter is in the red, do not continue to operate the machine. Battery damage may result.**

6. When the solution tank runs empty, press the 1-STEP switch raise the brush head. Keep the squeegee down and continue to vacuum until all the dirty water is picked up.

NOTE: *Brush motors will not work when the scrub head assembly raised.*

NOTE: See **TANK DRAINING** section to learn how to drain recovery and solution tanks.

CIRCUIT BREAKER / FUSES

The machine is equipped with 2 resettable circuit breakers(see machine components, item #12, item# 30) to protect the drive motor and the vacuum motor from damage. If the circuit breakers should trip, it can't be reset immediately. You must first determine what caused the breaker to trip, and allow the motor to cool down and then you can manually reset the circuit breakers.

The machine is also equipped with a 50A current transformer to protect the brush motors from damage. When replacing a fuse never substitute a higher Amps rated fuse than specified.

HOURLY METER

The hour meter (see machine components, item #4) records the number of total hours the brush motor has been powered on. Use the hour meter to determine when to perform recommended maintenance procedures and to record service history.

EMERGENCY STOP BUTTON/ BRAKE

The machine is equipped with an Electromagnetic Brake Mechanism on the Transaxle. When in case of Emergency, release the Control Handle bail(see machine components, item #27) or strike the Emergency stop button (see machine components, item #11), the machine will be braked and then stop. Reset the emergency stop button, turn on the Main power key switch, and then pull the control handle bail, the machine will be restart.

NOTE: *The machine can not be moved unless the Main Power Key Switch and the Control Handle bail be turned on.*



WARNING: Do Not Change the Default Settings of the Electromagnetic Brake Mechanism unless Authorized, otherwise it may cause Machine Damage or Personal Injury. Contact the Authorized Service center for machine repairs.

TANK DRAINING

1. Turn the machine off.
2. With the squeegee and scrub head in their "up" position, transport machine to approved area for draining tank(s).

DRAINING THE RECOVERY TANK

Any time scrubbing is completed, or when refilling solution tank, the recovery tank should be drained and cleaned.

! WARNING: If the recovery tank is not drained when the solution tank has been refilled, foam or water may enter the filter screen and cause damage to the vacuum motor.

1. While holding the drain hose (see machine components, item #19) upward, remove the cap and lower hose to drain.
2. Open the recovery tank cover and rinse out the tank. Use a rag to remove any excess dirt.
3. Clean the filter screen located in the recovery tank .

DRAINING THE SOLUTION TANK

Any time scrubbing operation is completed, the solution tank should be drained and cleaned.

1. Pull the solution tank level hose(see machine components, item #14) off the hose fitting, this will allow the solution to flow freely into a bucket or floor drain.
2. Remove the cover of the filter assembly(see machine components, item #20) to drain the solution tank, check the filter screen and clean up it if necessary.
3. Rinse the solution tank with clean water after every use. This will help prevent chemical buildup and clogging of the solution lines.
4. After rinsing out the tank, securely reconnect the tank level hose to the hose fitting, replace the filter assembly cover and be sure the filter screen and the "O" ring is in the correct position.

BATTERY CHARGING



WARNING: Fire Or Explosion Hazard.

Batteries Emit Hydrogen Gas. Keep Sparks and Open Flame Away. Keep Battery Compartment Propped Open When Charging.

NOTE: Use only approved chargers with the following specifications:

- Automatic shut off circuit
- Deep cycle charging
- Output current of 20-30 Amps
- Output voltage of 36 volts

ON-BOARD BATTERY CHARGER

As standard configuration, the machine is equipped with the On-board battery charger (see machine components, item #13). The settings of On-board battery charger had been set for the recommended batteries type.



WARNING: The On-board battery charger setting's change are to be completed by authorized service centers only. Failure to properly set will result in the batteries or charger damage.

1. Transport the machine to a well ventilated area.
2. Turn the machine off.
3. If charging wet (lead acid) batteries check the fluid level before charging.
4. Prop up the recovery tank by the support stand (see machine components, item #28) for ventilation.
5. Connect the charger's AC power supply cord to a properly grounded receptable.
6. The charger will automatically begin to charge, once the charging cycle begins, the indicator lights will progress from red, yellow to green. when the green indicator light comes on, the charging cycle is done. Unplug the charger cord.

NOTE: The machine will can not operate when charging.

OFF-BOARD BATTERY CHARGER (OPTION)

1. Place charger and machine in a well ventilated area.
2. Turn the machine off.

3. If charging wet (lead acid) batteries check the fluid level before charging.
4. Prop up the recovery tank by the support stand (see machine components, item #28) for ventilation.
5. Connect the charger's AC power supply cord to a properly grounded receptable.
6. Connect the charger's DC cord into the machine's battery receptacle at the rear of the machine.
7. The charger will automatically begin to charge and will autoatically shut off once the batteries are fully charged.
8. Upon completion of charging, disconnect the AC power supply cord first, and then disconnect the charger from the machine.

PREVENTATIVE MAINTENANCE



WARNING: Before performing any maintenance on the machine, be sure that the power is turned off, or the batteries are disconnected!



WARNING: Repairs are to be completed by Authorized service centers only. Any repairs completed by unauthorized persons will avoid the warrenty.

DAILY MAINTENANCE

1. Remove pad driver/ brush and clean with approved cleaner.
2. Drain recovery and solution tanks completely and rinse out with clean water. Visually check the recovery tank for debris and clean out as necessary.
3. Open recovery tank cover, Remove the vacuum fan filter and rinse it out with low pressure water, if dirty.



OPERATOR MANUAL

4. Raise the squeegee assembly off floor and wipe it down with a damp towel. Be sure to store the squeegee in the up position.
5. Clean machine with an approved cleaner and a damp towel.
6. Recharge the batteries.
7. Check the condition of the squeegee blade wiping edge, rotate blade if worn.

MONTHLY MAINTENANCE

1. Clean the battery tops to prevent corrosion.
2. Check for loose battery cable connections.
3. Inspect and clean the recovery tank cover seal. Replace it if damaged.
4. Lubricate all grease points and pivot points with silicon spray and approved grease.
5. Check the machine for loose nuts and bolts.
6. Check the machine for leaks.

MOTOR MAINTENANCE

1. Contact your local Distributor for any motor maintenance.
2. Motor should have the brushes checked every 250 hours. Brushes should be replaced when they are worn to a length of 10 mm or less.

BATTERY MAINTENANCE

! WARNING: Batteries emit hydrogen gas and an explosion or fire can result. Keep sparks and fire away from batteries at all times.

! WARNING: Whenever servicing batteries, be sure to wear protective gloves. Avoid contact with battery acid at all times.

NOTE: For the best machine performance, keep batteries charged at all times. Do not let them sit in a discharged condition.

1. Always follow the battery charging directions as outlined in the BATTERY CHARGING section of this manual.
2. Keep battery tops and terminals free from corrosion. A strong solution of baking soda and water is the best way to keep the batteries corrosion free. DO NOT ALLOW THE BAKING SODA / WATER SOLUTION TO ENTER THE BATTERY CELLS.

3. Use a wire brush with the baking soda solution to properly clean the battery posts and connections.
4. Check battery connections for wear and loose terminals. replace if necessary.

MACHINE STORAGE

1. Always store the machine indoors.
2. Always store the machine in a dry area.
3. Always store the machine in its upright position.
4. Always store the machine with the pad driver/brush raised off the floor.
5. Always store the machine with the squeegee assembly raised off the floor.
6. If storing in an area which may reach freezing temperatures, be sure to drain all fluids from the machine prior to storage. Any damage caused by freezing temperatures will not be covered by the warranty.
7. Drain the recovery tank.
8. Drain the solution tank of all fluid.

PUSHING OR TOWING THE MACHINE

If the machine becomes disabled, it can be pushed from the front or rear, but only tow it from the rear.

! WARNING: When servicing machine, do not push or tow the machine on inclines with the brake disabled.

Before attempting to push or tow the machine, disengage the brake as described below. To disengage the brake, you can turn the electronic brake lever to the other side.



OPERATOR MANUAL

CYLINDRICAL BRUSH MODEL

Install brush:

1. Raise scrub head off the floor and turn off the power.(remove key)
2. Remove brush door from scrub head by loosening the knob.
3. Attach brush door to the brush end that has the double row of bristles to install brush.
4. Check the brushes to ensure they are properly adjusted.

Inspect the Brush Pattern:

After installing a new set of cylindrical brushes check the brush pattern to ensure proper brush adjustment.

1. Measure the distance from the front edge of the scrub head to the floor and from the back edge of the scrub head to the floor.The measurements should be the same.
2. To level the scrub head, loosen the lock nut and turn the leveling screw clockwise to lower the rear of the scrub head or counter--clockwise to lower the front.

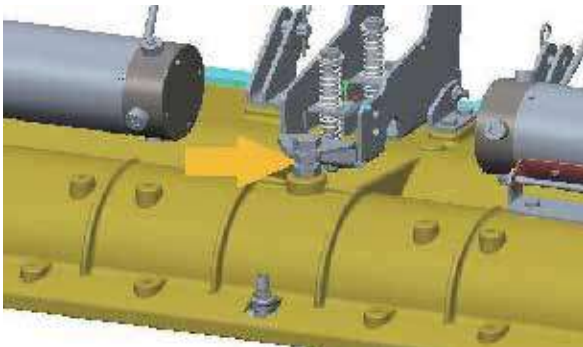

3. Position the machine on a dry dusty floor or apply a powdered substance, such as chalk.
- 4.Adjust the speed control knob to "zero"(🛑)
- 5.Shut off the solution flow.
- 6.Pull the control handle bail to create a brush pattern on the floor.
- 7.Raise the scrub head and pull the machine away.
- 8.Observe the brush pattern on floor. If the brush pattern is uneven or tapered, adjustment is required.

Correct Brush Pattern



To Adjust a Tapered Brush Pattern:

- 1.Remove the brush door from the brush.

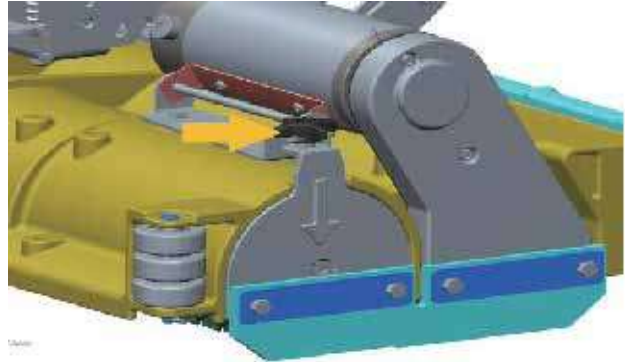

- 2.Hold the brush plug shaft with a wrench and loosen the 6mm hex screw.



- 3.To lower the brush end, turn the shaft clockwise for the front brush and counter--clockwise for the rear brush. Retighten hex screw.
 - 4.Recheck brush pattern.
- NOTE: Replace brushes when worn to 5/8" (15mm).

Cylindrical Assembly Instructions

Lower scrub head to the ground, then turn off the power (remove key).

STEP#1: Remove Front Cover

1. Remove knob (2) from solution tank.
2. Disconnect cable (1) of the led light.
3. Remove front cover from solution tank.

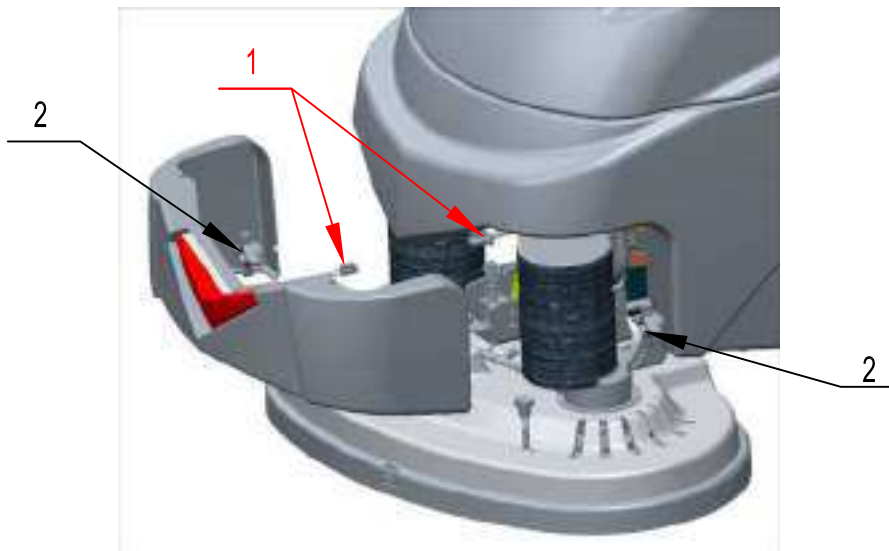

STEP#2: Remove Disc Scrub Head Assembly

1. Remove cotter pin and pins (5) from scrub head lift bracket, then remove cotter pin and pin (3) from spring bracket.
2. Remove lock nut and hex bolt (6) from roller guide (1).
3. Disconnect motor power cords (2).
4. Loosen clamp on the solenoid valve and remove tubing (4).
5. Remove scrub head assembly.

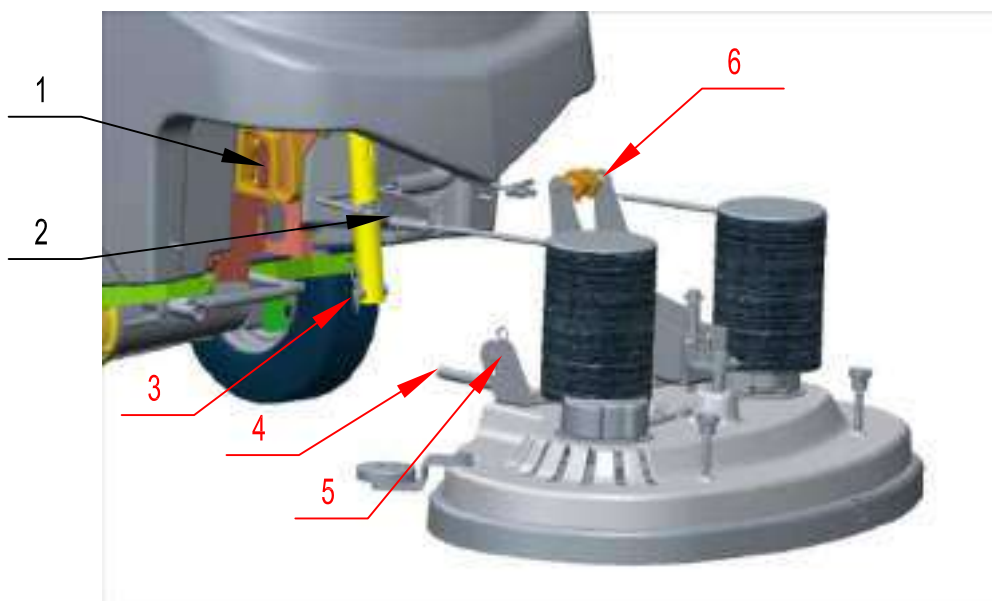

STEP#3: Assembly Cylindrical Scrub Head Group

1. Adjust initial position of sleeve nut(10) on the actuator(1) to right place(L) by rotating manually.
2. Place cylindrical scrub head under solution tank.
3. Connect tubing(3) and fasten clamp.
4. Insert pins into cylindrical scrub head lift bracket(4) through arm(9) installing on the frame, and place cotter pin into holes on the pin.
5. Insert pin into spring bracket(5) through sleeve nut installing on the actuator, and place cotter pin into holes on the pin(6).
6. Insert hex bolt into roller guide(8) through lifting bracket and fasten lock nut(2).
7. Connect motor power cords(7).

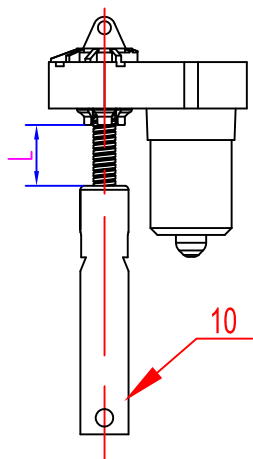

L=55±5MM

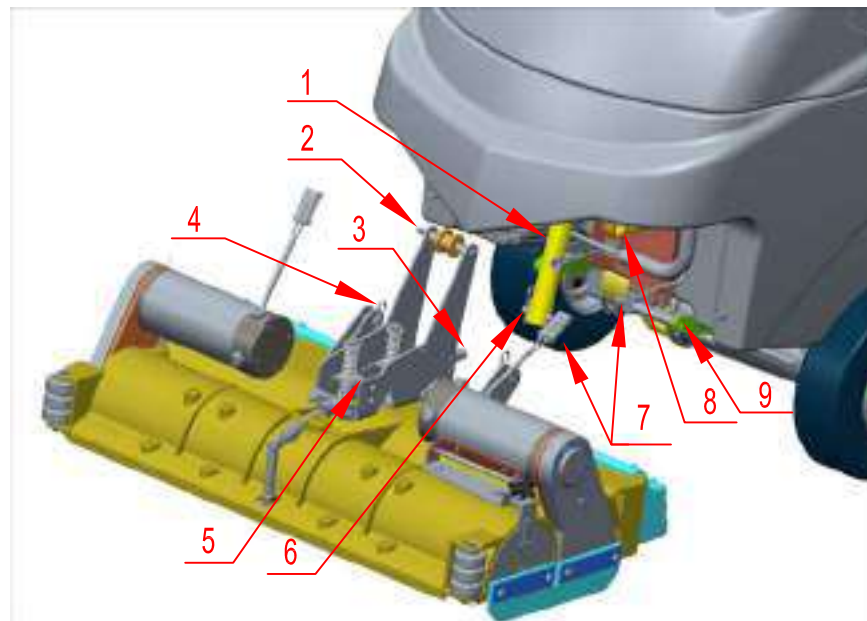

STEP#4: Assembly Front Cover

1. Connect cable of the led light(3).
2. Install front cover through stud fixing(1) on solution tank.
3. Fasten the knobs(2).

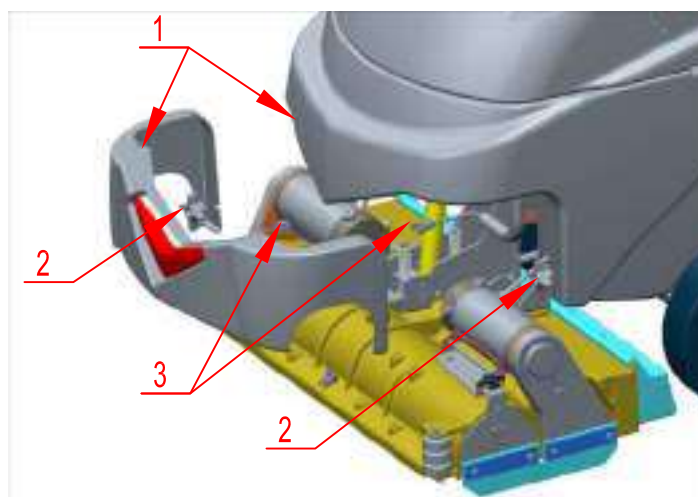

BASIC TROUBLESHOOTING

PROBLEM	CAUSE	SOLUTION
Machine will not operate	Control handle bail not pulled	Pull control handle bail
	Batteries need to be charged	Charge batteries
	Bad battery(s)	Replace battery(s)
	Loose battery cable	Tighten loose cable
	Emergency stop button activated	Reset Emergency stop button
	Main PCB fuse blown	Contact ICE service center
	Faulty key switch	Contact ICE service center
Brush motor will not operate	1-STEP scrub head up/down switch is off	Turn on the 1-STEP switch
	Battery meter lockout activated	Recharge batteries
	Brush motor fuse blown	Replace 50A current transformer
	Brush motors over load	Turn on / off the 1-STEP switch
	Faulty control handle bail switch	Contact ICE service center
	Faulty brush motor or wiring	Contact ICE service center
	Worn Motor carbon brushes	Contact ICE service center
	Bad solenoid	Contact ICE service center
Machine does not propel	The Main Power Key Switch be Turned off, the Control handle bail not pulled	Turn on the Key switch, Pull the control handle bail
	Tripped drive motor circuit breaker	Reset drive motor circuit breaker button
	Faulty transaxle motor or wiring	Contact ICE service center
	Worn Motor carbon brushes	Contact ICE service center
Vacuum motor will not operate	Recovery tank is full	Drain recovery tank
	Tripped vacuum motor circuit breaker	Reset vacuum circuit breaker button
	Faulty vacuum motor or wiring	Contact ICE service center
	Worn Motor carbon brushes	Contact ICE service center
Little or no solution flow	Ball valve set too low or shut off	Turn on the ball valve
	Solution flow control knob set too low or shut off	Adjust solution control flow knob
	Clogged solution tank filter or solution hose	Clean solution tank filter or flush out solution hose
	Clogged solution Solenoid valve	Remove valve and clean
Poor water pick up	Recovery tank is full	Drain recovery tank
	Loose drain hose cap	Tighten cap
	Clogged filter located in recovery tank cover	Clean filter
	Clogged squeegee assembly	Clean squeegee assembly
	Worn squeegee blades	Replace or rotate squeegee blades
	Incorrect squeegee blade deflection	Adjust squeegee blade height
	Loose vacuum hose connections	Secure hose connections
	Clogged vacuum hose	Remove clogged debris
	Damaged vacuum hose	Replace vacuum hose
	Recovery tank cover not in place	Properly position cover
	Damaged recovery tank cover seal	Replace seal
	Faulty vacuum motor	Contact ICE service center
Short run time	Low battery charge	Recharge batteries
	Low battery charge	Fully recharge batteries
	Defective batteries	Replace batteries
	Batteries need maintenance	See BATTERY MAINTENANCE
	Faulty battery charger	Repair or replace battery charger
	Down pressure lever is set for extra scrub head pressure	Lower down pressure lever

TECHNICAL SPECIFICATIONS

MODEL	i36BT
DIMENSIONS L X W X H	1650 X 865 X 1130 mm
WEIGHT	185Kg
WEIGHT WITH BATTERIES	440 Kg
SOLUTION TANK CAPACITY	118 L / 31Gal
RECOVERY TANK CAPACITY	120 L / 31.5 Gal
SQUEEGEE WIDTH	1185 mm / 46.5 in
CLEANING PATH WIDTH	800mm / 32 in
PRODUCTIVITY RATE	3250 m ² h
DRIVE SYSTEM	Transaxle, 36VDC, 350W
TRAVEL SPEED, MAXIMUM	Cleaning: 65m/Min Transporting: 72 m/Min
MINIMUM ALSLE TURN	1600mm
PAD/BRUSH PRESSURE	40kg / 65kg / 90kg
CYLINDRICAL PRESSURE	40kg
SOLUTION FLOW RATE	0 ~ 3200ml/Min
BRUSH MOTOR(S)	650WX2,36VDC
BRUSH DIAMETER-SPEED	406mmx2,200RPM
CYLINDRICAL BRUSH MOTOR(S)	560WX2, 36VDC
CYLINDRICAL (LXD)-SPEED	800X150mmX2,750RPM
VACUUM MOTOR	600W,36VDC
WATER LIFT - AIR FLOW	73 inch
BATTERIES	6 - 6V, 260AH optional 305AH @ 20 hr
RUN TIME PER CHARGE	4 or 4.5 Hours
VOLTAGE DC	36V
DECIBEL RATING AT OPERATOR'S EAR, INDOORS	68 dB(A)
GRADE LEVEL, MAX	10% (6°)

RECOVERY TANK GROUP

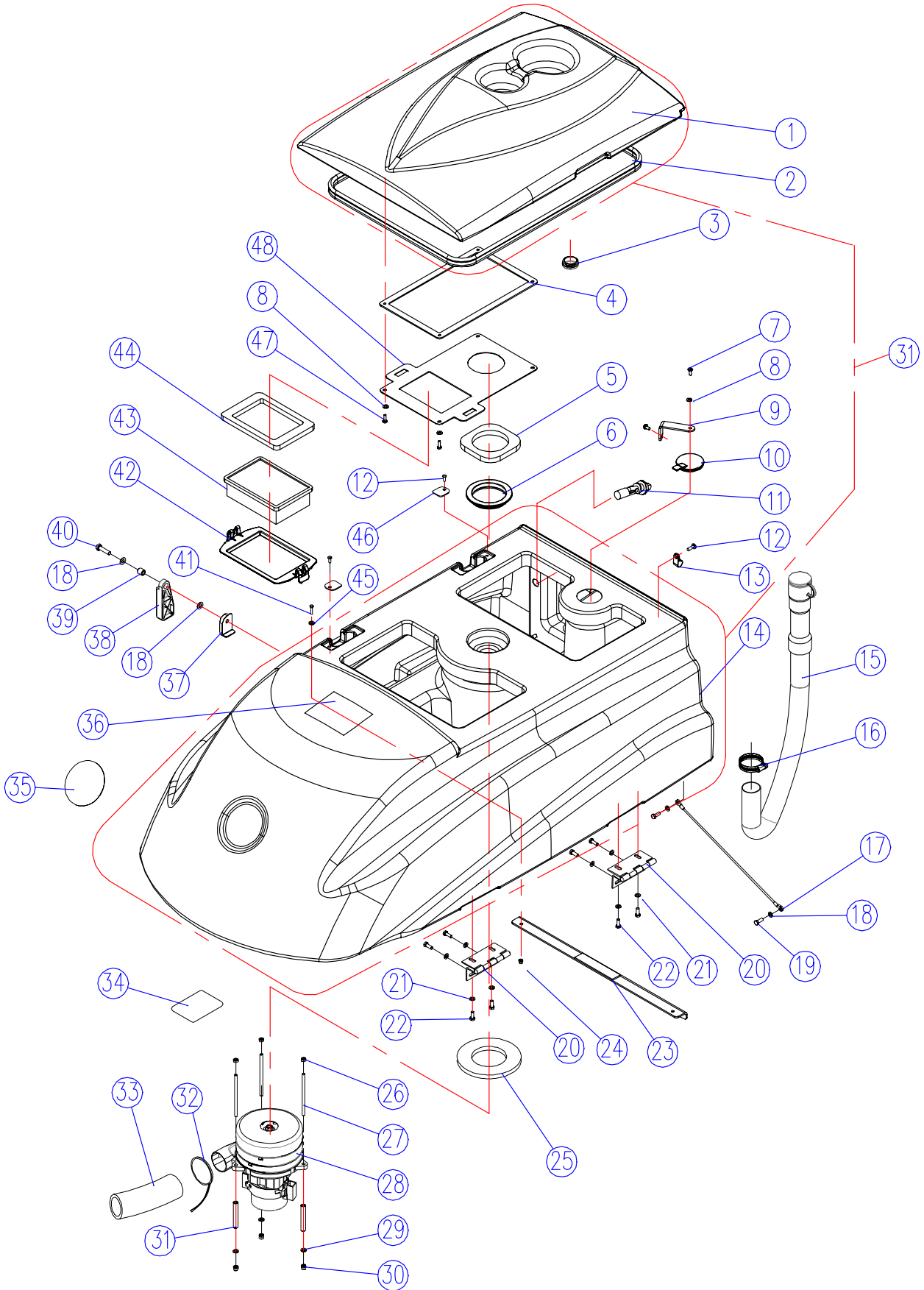

RECOVERY TANK GROUP

DIA NO.	PART NUMBER	SERIAL NUMBER	DESCRIPTION	NO. REQ'D
1	8230103	100175- for i36BT	RECOVERY TANK COVER	1
		- for i36BT-CY		
		-100174 for i36BT	RECOVERY TANK COVER(Before modification)	
		-100161 for i36BT-CY		
2	8230201A		SEAL	1
3	8011005		CAP	1
4	8230209		GASKET	1
5	8230208		GASKET, SCREEN	1
6	8230204		SCREEN	1
7	1321213		SELF-TAPPING SCREW,ST4.2 X 13	2
8	1421510		WASHER,M5 X 10 X 1	9
9	8113007		STRIP	1
10	8131003		CAP	1
11	8310238		SENSOR, LEVEL, LIQUID,	1
12	1221512		SCREW,M5X12	3
13	8113009		CLAMP	1
14	8230102	100175- for i36BT	RECOVERY TANK	1
		- for i36BT-CY		
		-100174 for i36BT	RECOVERY TANK(Before modification)	
		-100161 for i36BT-CY		
15	8131030		DRAIN HOSE	1
16	1962050		CLAMP	1
17	8230205		CABLE	1
18	1421816		FLAT WASHER,M8 X 16 X 1.6	4
19	1021820		HEX BOLT,M8 X 20	2
20	8111300		HINGE ASSEMBLY	2
21	1421618		FLAT WASHER,M 6 X 18 X 1.6	8
22	1021616		HEX BOLT,M6 X 16	8
23	8230135	100143- for i36BT	BRACKET,RECOVERY TANK	1
		100159- for i36BT-CY		
24	1123507		LOCK NUT,M5	2
25	8112005		GASKET, VACUUM MOTOR	1
26	1121605		HEX NUT,M6	3
27	8210209		STUD,M6 X 110	3
28	8230200		3 STAGE VACUUM MOTOR,36VDC,640W,KIT	1
29	1421612		FLAT WASHER,M6 X 12 X 1.6	5
30	1123608		LOCK NUT,M6	3
31	8230110		KIT,RECOVERY TANK(Replace the old version)	1

PARTS LIST

RECOVERY TANK GROUP

DIA NO.	PART NUMBER	SERIAL NUMBER	DESCRIPTION	NO. REQ'D
31	8210216		BUSHING	3
32	1914300		TIE, NYLON, 5 X 300	1
33	8132007		MUFFLER, VACUUM MOTOR	1
34	8230126		LABEL, BATTERY INSTALLATION	1
35	4010316		ICE LOGO	1
36	8111022		WARNING LABEL	1
37	8111008		BRACKET	1
38	8111007		RECOVERY TANK SUPPORT	1
39	8115404		SLEEVE, P/M	1
40	1021830		HEX BOLT,M8 X 30	1
41	1221510		SCREW,M5 X 20	2
42	8230210		BRACKET,FILTER	1
43	8320237		FILTER,DUST	1
44	8310230		GASKET,FILTER	1
45	1421511		FLAT WASHER,M5 X 12 X 1	2
46	8111016		PLATE	2
47	1221510		SCREW,M5 X 10	6
48	8230207		PLATE	1

SOLUTION TANK GROUP

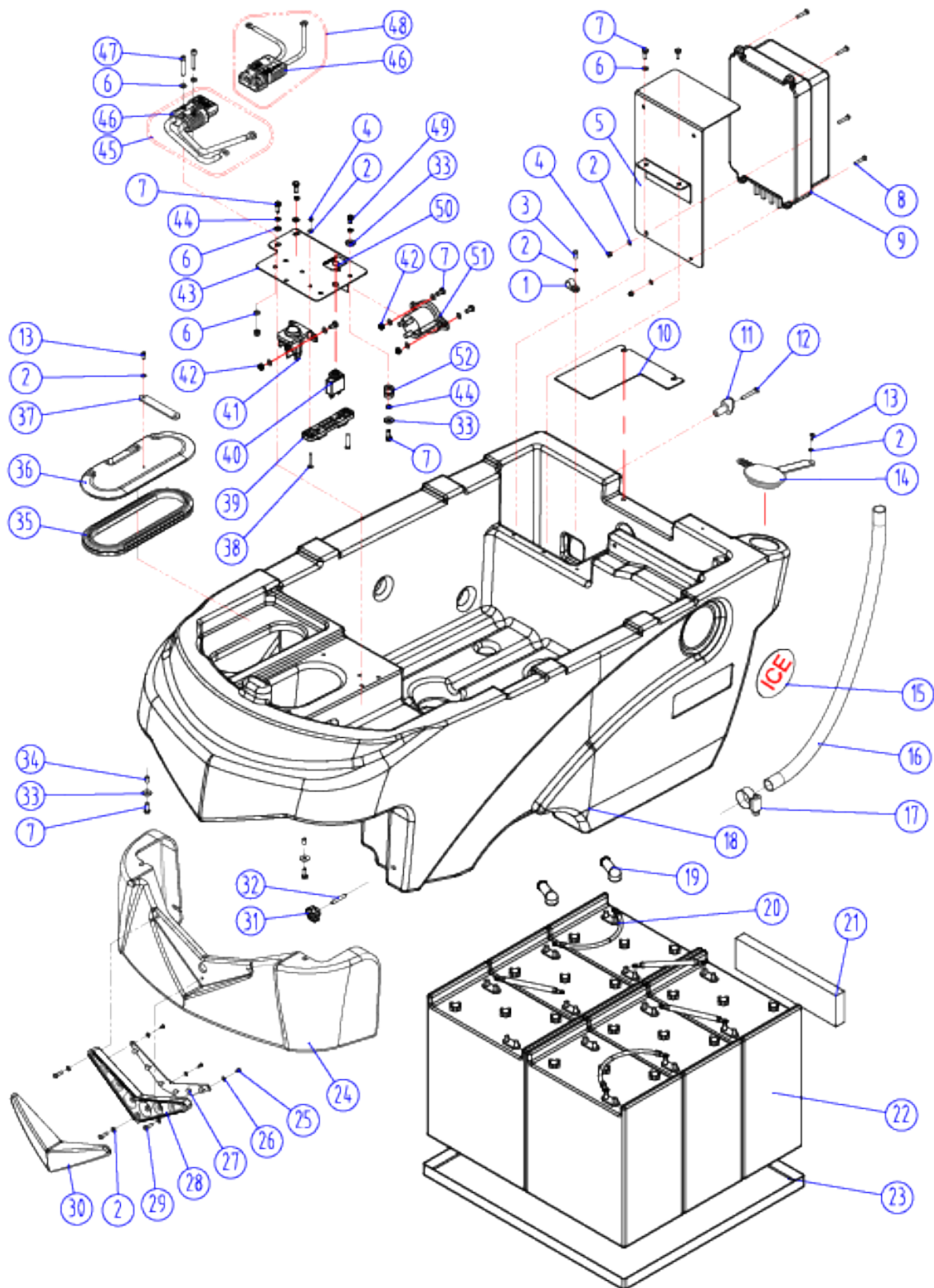

SOLUTION TANK GROUP

DIA NO.	PART NUMBER	SERIAL NUMBER	DESCRIPTION	NO. REQ'D
1	6210131		NYLON, CLAMP	6
2	1421510		FLAT WASHER,M5 X 10 X 1	20
3	1221512		SCREW,M5 X 12	9
4	1123507		LOCK NUT,M5	6
5	8230114		BRACKET, ON BOARD CHARGER	1
6	1421612		FLAT WASHER,M6 X 12 X 1.6	14
7	1021616		HEX BOLT,M6 X 16	12
8	1221525		SCREW,M5 X 25	4
9	8230117-US		ON BOARD CHARGER,36VDC,KIT [US]	1
	8230131-K		ON BOARD CHARGER,36VDC,KIT [EU]	1
	8230132		ON BOARD CHARGER,36VDC,KIT [UK]	1
10	8230127		PLATE	1
11	8210112		HOOK, CORD	2
12	1222641		SCREW,M6 X 40	2
13	1321213		SELF-TAPPING SCREW,ST4.2 X 13	2
14	8210113		CAP, SOLUTION FILL	1
15	4010316		ICE LOGO	2
16	8230134	100175- for i36BT	CLEAN TUBING	1
		- for i36BT-CY		
	8210145	-100174 for i36BT	CLEAN TUBING(OLD)	
		-100161 for i36BT-CY		
17	1962025		CLAMP,16 - 25mm	1
18	8230101		SOLUTION TANK	1
19	8114753		JACKET, BATTERY TERMINAL, BLACK	12
20	8230705		BATTERY CONNECT CABLE, BLACK	5
21	8113013		SPACER, BATTERY	4
22	8210105		BATTERY, 260AH @ 20Hr	6
	8230120		BATTERY, 305AH @ 20Hr (OPTIONAL)	6
23	8230121		BATTERY TRAY	1
24	8230104		COVER, FRONT	1
25	1321110		SELF-TAPPING SCREW,ST3.5 X 10	3
26	1421409		FLAT WASHER,M4 X 9 X 0.8	3
27	8230750		LED LIGHT,36V,KIT	1
28	8133601		LED LIGHT MOUNTING BASE	1
29	1221520		SCREW,M5 X 20	3
30	8133602		LED LIGHT COVER	1

PARTS LIST

SOLUTION TANK GROUP

DIA NO.	PART NUMBER	SERIAL NUMBER	DESCRIPTION	NO. REQ'D
31	8210518		KNOB, M8	2
32	1535830		SET SCREW,M8 X 30	2
33	1421618		PLAIN WASHER ,M6 X 18 X 1.6,SS	6
34	8113112		BUSHING	2
35	8113030		SEAL	1
36	8113002		COVER	1
37	8113007		STRAP	1
38	1221520		SCREW,M5 X 20	2
39	8230711		CURRENT TRANSFORMER, 50A	1
40	8114703		CIRCUIT BREAKER, 35A	1
41	8230708		SOLENOID SWITCH, 36VDC	1
42	1123608		LOCK NUT, M6	4
43	8230128		BRACKET, SOLENOID SWITCH	1
44	1422616		LOCK WASHER, M6	6
45	8230707		KIT, BATTERY CONNECT CABLE	1
46	8230714		CONNECTOR, SB175-GREY	2
47	1521635		SCREW, HEX SOCKET, M6 X 35	2
48	8230706		KIT, BATTERY CONNECT CABLE	1
49	1021610		HEX BOLT, M6 X 10	2
50	8144024		LABEL, CIRCUIT BREAKER	2
51	8230702		SOLENOID SWITCH, 36VDC	1
52	8114705		STAND-OFF, M6, RED	2

FRAME & DRIVE GROUP

DIA NO.	PART NUMBER	SERIAL NUMBER	DESCRIPTION	NO. REQ'D
1	8211505		SHOULDER BOLT,M12 X 30 X M10	1
2	1421312		FLAT WASHER,M12 X 32 X 1.5	1
3	8210508		SPIRNG	1
4	8135001		PLASTIC THRUST WASHER,M12 X 30 X 1.5	2
5	8211501		BRACKET, SQGE LIFT	1
6	1123810		LOCK NUT,M8	7
7	8211507		KNOB, M8	1
8	8211506		PIN	1
9	1123608		LOCK NUT,M6	5
10	1421618		FLAT WASHER,M6 X 18 X 1.6	2
11	8210503		BRACKET, SQGE MNTG	1
12	8114511		BALL JOINT,M6	1
13	8211504		SHOULDER BOLT,M12 X 7 X M8	4
14	1121807		NUT,M8	1
15	1421824		FLAT WASHER,M8 X 24 X 2	4
16	8211508		BUSHING	1
17	8230512		BRACKET, SWING	1
18	1421020		FLAT WASHER,M10 X 20 X 2	15
19	1021030		HEX BOLT,M10 X 30	8
20	1123012		LOCK NUT,M10	13
21	1124111		NUT,CAP	6
22	1123111		LOCK NUT,7/16"- 20UNF	6
23	1421120		FLAT WASHER,M12.1 X 20 X 2	6
24	8230129		WHEEL,12", FOAM FILL	2
	8230116		WHEEL,12", PNEUMATIC (OPTIONAL)	2
25	8230118		BRACKET, TRANSAXLE MOUNTING	2
26	8230810		TRANSAXLE, 36VDC,KIT	1
	8230811		ELECTRIC BRAKE KIT	1
27	8230119		5",CASTER	2
28	1022809		HEX BOLT,M8 X 90	1
29	1021820		HEX BOLT,M8 X 20	5
30	1422821		LOCK WASHER,M8	5

PARTS LIST

FRAME & DRIVE GROUP

DIA NO.	PART NUMBER	SERIAL NUMBER	DESCRIPTION	NO. REQ'D
31	1421828		FLAT WASHER,M8 X 28 X 2	5
32	8310144	100293- for i36BT	SLEEVE	4
		- for i36BT-CY		
33	8310118	100293- for i36BT	ARM, SCRUB HEAD LIFTING	2
		- for i36BT-CY		
	8210115	-100292 for i36BT	ARM, SCRUB HEAD LIFTING(OLD)	
		-100161 for i36BT-CY		
34	8230136	100293- for i36BT	T-BUSHING	2
		- for i36BT-CY		
35	1123012		LOCK NUT,M10	2
36	8230137	100293- for i36BT	BUSHING	2
		- for i36BT-CY		
	8210116	-100292 for i36BT	BUSHING(OLD)	
		-100161 for i36BT-CY		
37	1032090	100293- for i36BT	HEX BOLT,M10 X 90	2
		- for i36BT-CY		
38	8230140	100293- for i36BT	FRAME	1
		- for i36BT-CY		
	8230105	-100292 for i36BT	FRAME(OLD)	1
		-100161 for i36BT-CY		
39	1021025		HEX BOLT,M10 X 25	4

SCRUB HEAD GROUP

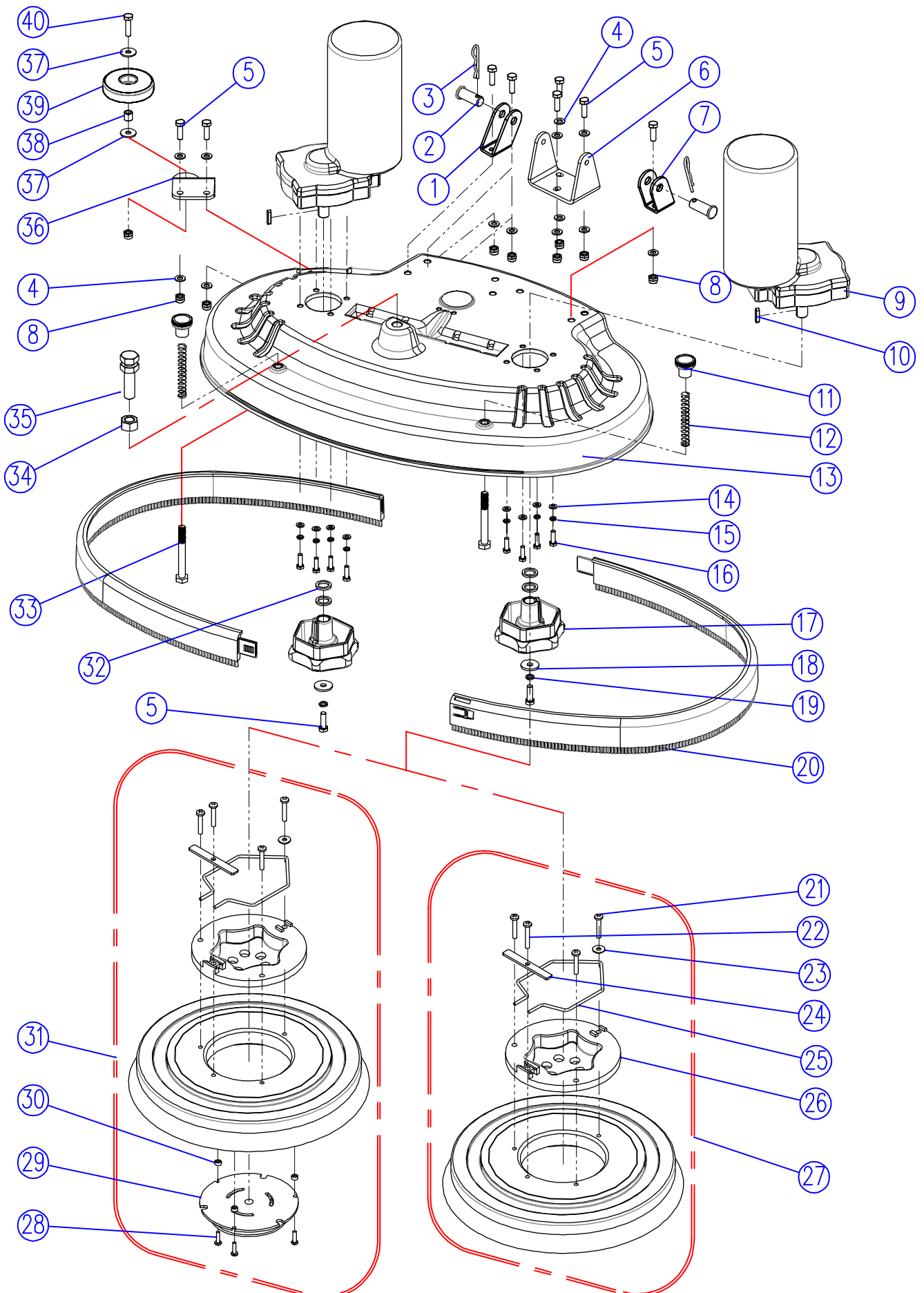

PARTS LIST

SCRUB HEAD GROUP

DIA NO.	PART NUMBER	SERIAL NUMBER	DESCRIPTION	NO. REQ'D
1	8230830	100293- for i36BT	BRACKET, SCRUB HEAD LIFT, RIGHT	1
	8210830	-100292 for i36BT	BRACKET, SCRUB HEAD LIFT, RIGHT(OLD)	1
2	8230138	100293- for i36BT	PIN	2
	8210807	-100292 for i36BT	PIN(OLD)	2
3	8210309		PIN, COTTER	2
4	1421816		FLAT WASHER,M8 X 16 X 1.6	14
5	1021825		HEX BOLT,M8 X 25	11
6	8210806		BRACKET, ACTUATOR MNTG	1
7	8230820	100293- for i36BT	BRACKET, SCRUB HEAD LIFT, LEFT	1
	8210820	-100292 for i36BT	BRACKET, SCRUB HEAD LIFT, LEFT(OLD)	1
8	1123810		LOCK NUT,M8	10
9	8230300		BRUSH MOTOR, 36VDC, 630W, KIT	2
10	1655025		KEY, 5 X 5 X 25	2
11	8210808		KNOB, M10	2
12	8210809		SPRING	2
13	8230139	100293- for i36BT	HOUSING, SCRUB HEAD,i36BT	1
	8230301	-100292 for i36BT	HOUSING, SCRUB HEAD,i36BT(OLD)	1
14	1421612		FLAT WASHER,M6 X 12 X 1.6	8
15	1422616		LOCK WASHER, M6	8
16	1021620		HEX BOLT,M6 X 20	8
17	8210805		HUB, BRUSH DRIVE	2
18	1421828		FLAT WASHER,M8 X 28 X 3.0	2
19	1422821		LOCK WASHER,M8	2
20	8218050		BUMPER, SCRUB HEAD	2
21	1221635		SCREW, M6 X 35	12
22	1221640		SCREW, M6 X 40	4
23	1421618		FLAT WASHER,M6 X 18 X 1.6	4
24	8210861		RETAINER BAR	4
25	8210862		SPRING, G-400S	4
26	9000004		CLUTCH, G-400S	4
27	9050016		BRUSH ASSEMBLY, 16 INCH	2
28	1321325		SELF-TAPPING SCREW,ST5 X 25	6
29	9000003		CENTER LOCK, #3	2
30	8116040		SPACER, 6.5 X 14.5 X 7.0	6
31	9040016		PAD DRIVER, 15 INCH	2
32	8210804		SPACER	4
33	1022090		HEX BOLT,M10 X 90	2
34	1111215		HEX NUT, M16	1
35	8210811		AJUSTMENT STUD, M16	1
36	8210810		BRACKET, ROLLER MNTG	1
37	1421824		FLAT WASHER,M8 X 24 X 2	2
38	8115404		SLEEVE, P/M	1
39	8116009		PROTECTIVE WHEEL	1
40	1021830		HEX BOLT,M8 X 30	1

SCRUB HEAD LIFT GROUP

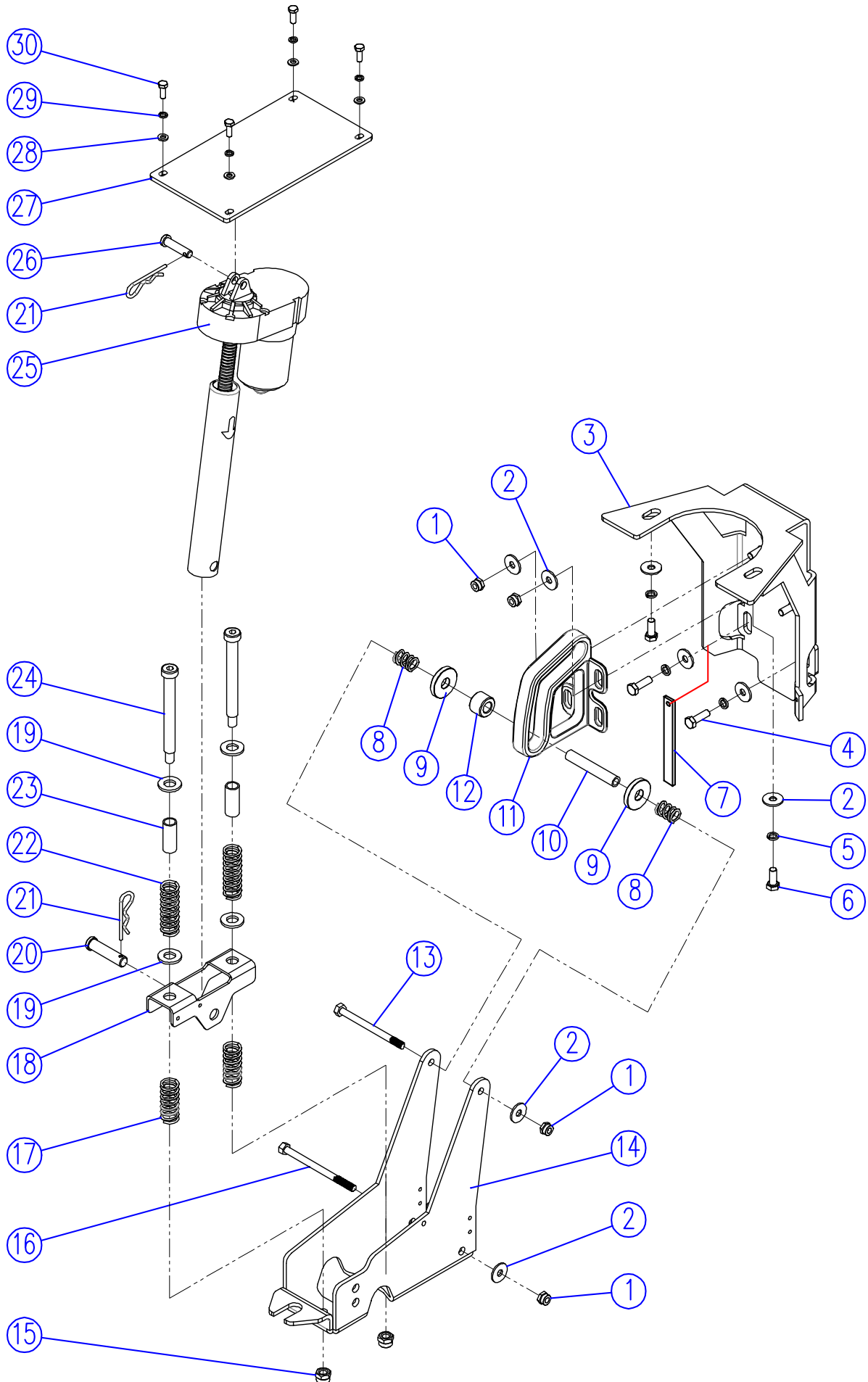

SCRUB HEAD LIFT GROUP

DIA NO.	PART NUMBER	SERIAL NUMBER	DESCRIPTION	NO. REQ'D
1	1123810		LOCK NUT,M8	6
2	1421824		FLAT WASHER,M8 X 24 X 2	10
3	8210306		BRACKET, GUIDE MNTG	1
4	1021825		HEX BOLT,M8 X 25	2
5	1422821		LOCK WASHER,M8	4
6	1021820		HEX BOLT,M8 X 20	2
7	8210118		STATIC STRAP	1
8	8210311		SPRING	2
9	8210312		WASHER, PM	2
10	8210314		SHAFT	1
11	8210310		GUIDE, ROLLER	1
12	8210313		ROLLER	1
13	1022800		HEX BOLT,M8 X 100	1
14	8210316		BRACKET, SCRUB LIFT	1
15	1123008		LOCK NUT,3/8	2
16	1022811		HEX BOLT,M8 X 110	1
17	8210319		SPRING	2
18	8210317		BRACKET, SPRING	1
19	1421132		FLAT WASHER,M 12 X 32 X 1.5	4
20	8210322		PIN	1
21	8210309		PIN, COTTER	2
22	8210318		SPRING	2
23	8230311		SLEEVE	2
24	8210321		BOLT, SHOULDER, 3/8	2
25	8230302		ACTUATOR, 36VDC	1
26	8210301		PIN	1
27	8210303		BRACKET, ACTUATOR MNTG	1
28	1421612		FLAT WASHER,M6 X 12 X 1.6	4
29	1422616		LOCK WASHER,M6	4
30	1021616		HEX BOLT,M6 X 16	4

SQUEEGEE GROUP (46.5 INCH STANDARD)

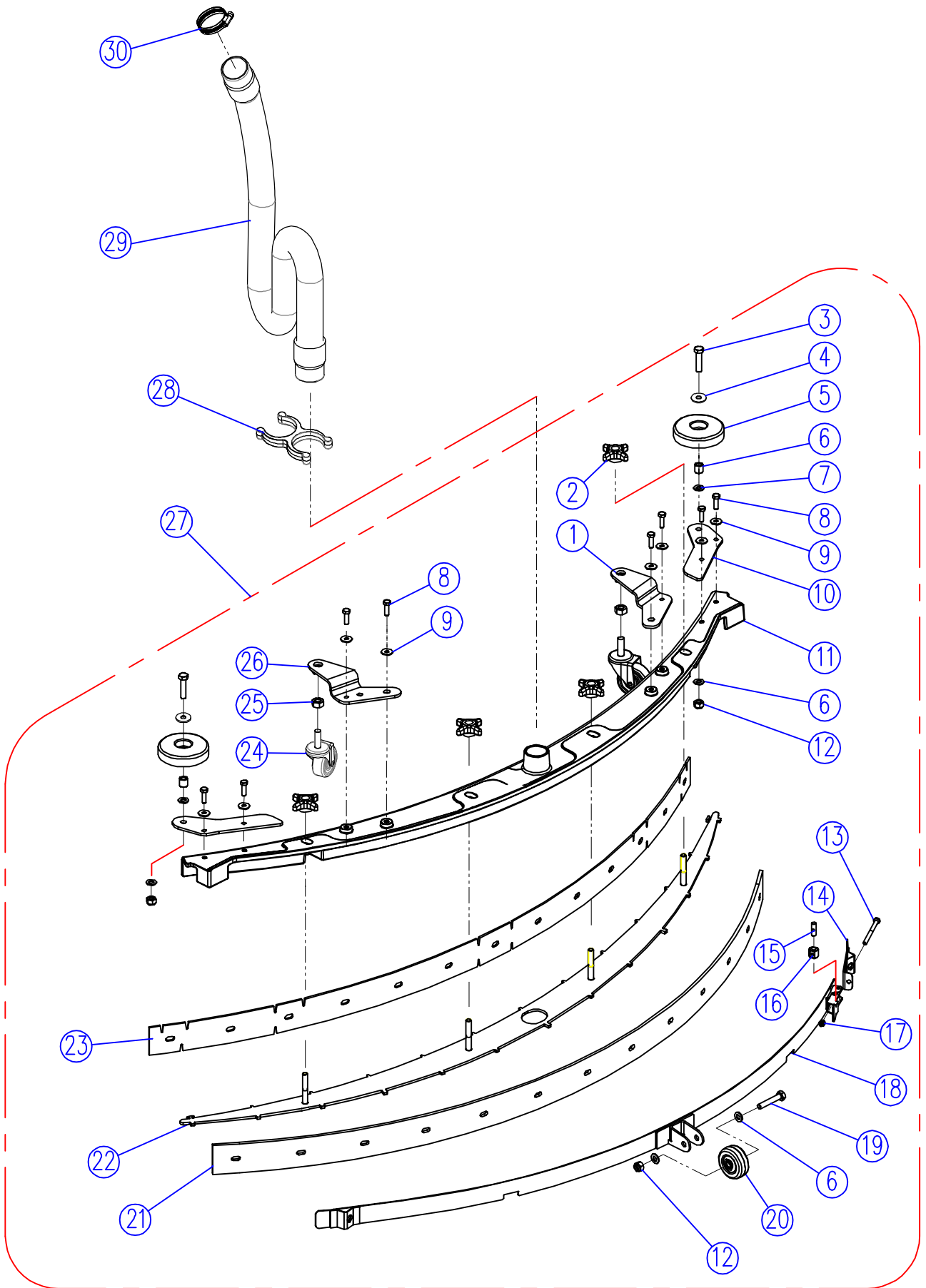

PARTS LIST

SQUEEGEE GROUP (46.5 INCH STANDARD)

DIA NO.	PART NUMBER	SERIAL NUMBER	DESCRIPTION	NO. REQ'D
1	8118300		RIGHT BRACKET	1
2	8210518		STAR KNOB,M8	4
3	1021835		HEX BOLT,M8 X 35	2
4	1421824		FLAT WASHER,M8 X 24 X 2.0	2
5	8116009		PROTECTIVE WHEEL	2
6	8115404		BEARING, JOURNAL	2
7	1421816		FLAT WASHER,M8 X 16 X1 .6	6
8	1021616		HEX BOLT,M6 X 16	8
9	1421618		FLAT WASHER,M6 X 18 X 1.6	8
10	8210515		BRACKET, ROLLER MNTG	2
11	8230501		SQUEEGEE HOUSING	1
12	1123810		LOCK NUT,M8	2
13	1221575		SCREW,M5 X 75	1
14	8210525		SHORT CLAMP ASSEMBLY	1
15	8118624		SHAFT	1
16	8118623		SPACER	1
17	1123507		LOCK NUT,M5	1
18	8210520		CLAMP ASSEMBLY, SQUEEGEE	1
	8211520		CLAMP ASSEMBLY, WITHOUT WHEEL(OP)	1
19	1022845		HEX BOLT,M8 X 45	1
20	8210527		WHEEL, 2 INCH	1
21	8230504		SQUEEGEE BLADE, REAR, LINATEX	1
	8230507		SQUEEGEE BLADE, REAR, PU (OPTIONAL)	1
22	8230502		RETAINER,SQUEEGEE	1
23	8230503		SQUEEGEE BLADE, FRONT, LINATEX	1
	8230506		SQUEEGEE BLADE, FRONT, PU (OPTIONAL)	1
24	8118400		CASTER, 2 INCH	2
25	1121008		HEX NUT,M10	2
26	8118200		LEFT BRACKET	1
27	8230500		SQUEEGEE ASSEMBLY	1
28	8118109		HOLDER VACUUM HOSE	1
29	8118015		VACUUM HOSE	1
30	1962050		CLAMP	1

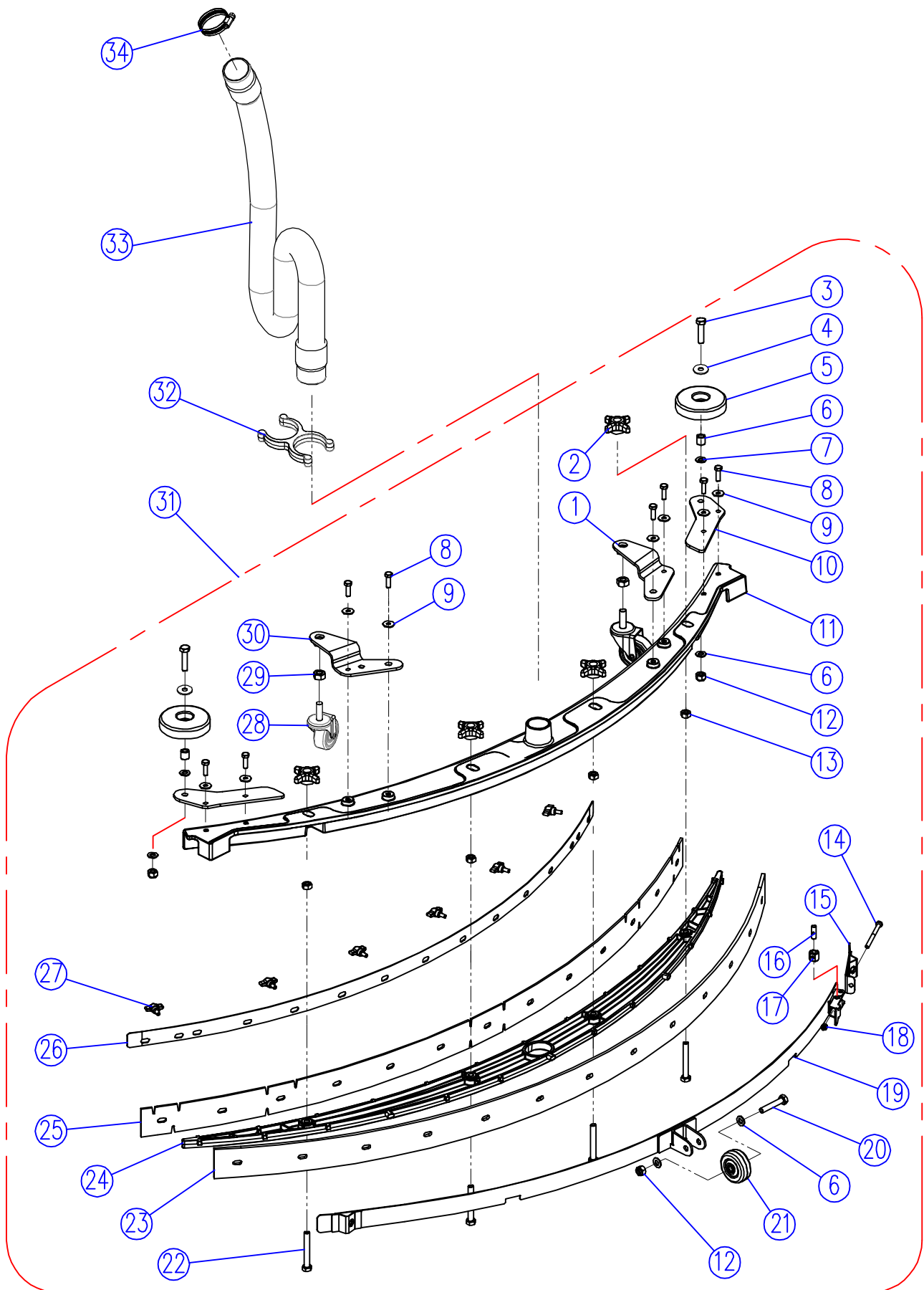
SQUEEGEE GROUP (OLD)

PARTS LIST

SQUEEGEE GROUP (OLD)

DIA NO.	PART NUMBER	SERIAL NUMBER	DESCRIPTION	NO. REQ'D
1	8118300		RIGHT BRACKET	1
2	8210518		STAR KNOB,M8	4
3	1021835		HEX BOLT,M8 X 35	2
4	1421824		FLAT WASHER,M8 X 24 X 2.0	2
5	8116009		PROTECTIVE WHEEL	2
6	8115404		BEARING, JOURNAL	2
7	1421816		FLAT WASHER,M8 X 16 X1 .6	6
8	1021616		HEX BOLT,M6 X 16	8
9	1421618		FLAT WASHER,M6 X 18 X 1.6	8
10	8210515		BRACKET, ROLLER MNTG	2
11	8210511		SQUEEGEE HOUSING	1
12	1123810		LOCK NUT,M8	2
13	1121807		HEX NUT,M8	4
14	1221575		SCREW,M5 X 75	1
15	8210525		SHORT CLAMP ASSEMBLY	1
16	8118624		SHAFT	1
17	8118623		SPACER	1
18	1123507		LOCK NUT,M5	1
19	8210520		CLAMP ASSEMBLY, SQUEEGEE	1
	8211520		CLAMP ASSEMBLY, WITHOUT WHEEL(OP)	1
20	1022845		HEX BOLT,M8 X 45	1
21	8210527		WHEEL, 2 INCH	1
22	1021860		HEX BOLT,M8 X 60	4
23	8210514		SQUEEGEE BLADE, REAR, LINATEX	1
	8210517		SQUEEGEE BLADE, REAR, PU (OPTIONAL)	1
24	8210512		RETAINER,SQUEEGEE	1
25	8210513		SQUEEGEE BLADE, FRONT, LINATEX	1
	8210516		SQUEEGEE BLADE, FRONT, PU (OPTIONAL)	1
26	8210519		CLAMP, FRONT BLADE	1
27	8210530		KNOB, M6	6
28	8118400		CASTER, 2 INCH	2
29	1121008		HEX NUT,M10	2
30	8118200		LEFT BRACKET	1
31	8210510		SQUEEGEE ASSEMBLY	1
32	8118109		HOLDER VACUUM HOSE	1
33	8118015		VACUUM HOSE	1
34	1962050		CLAMP	1

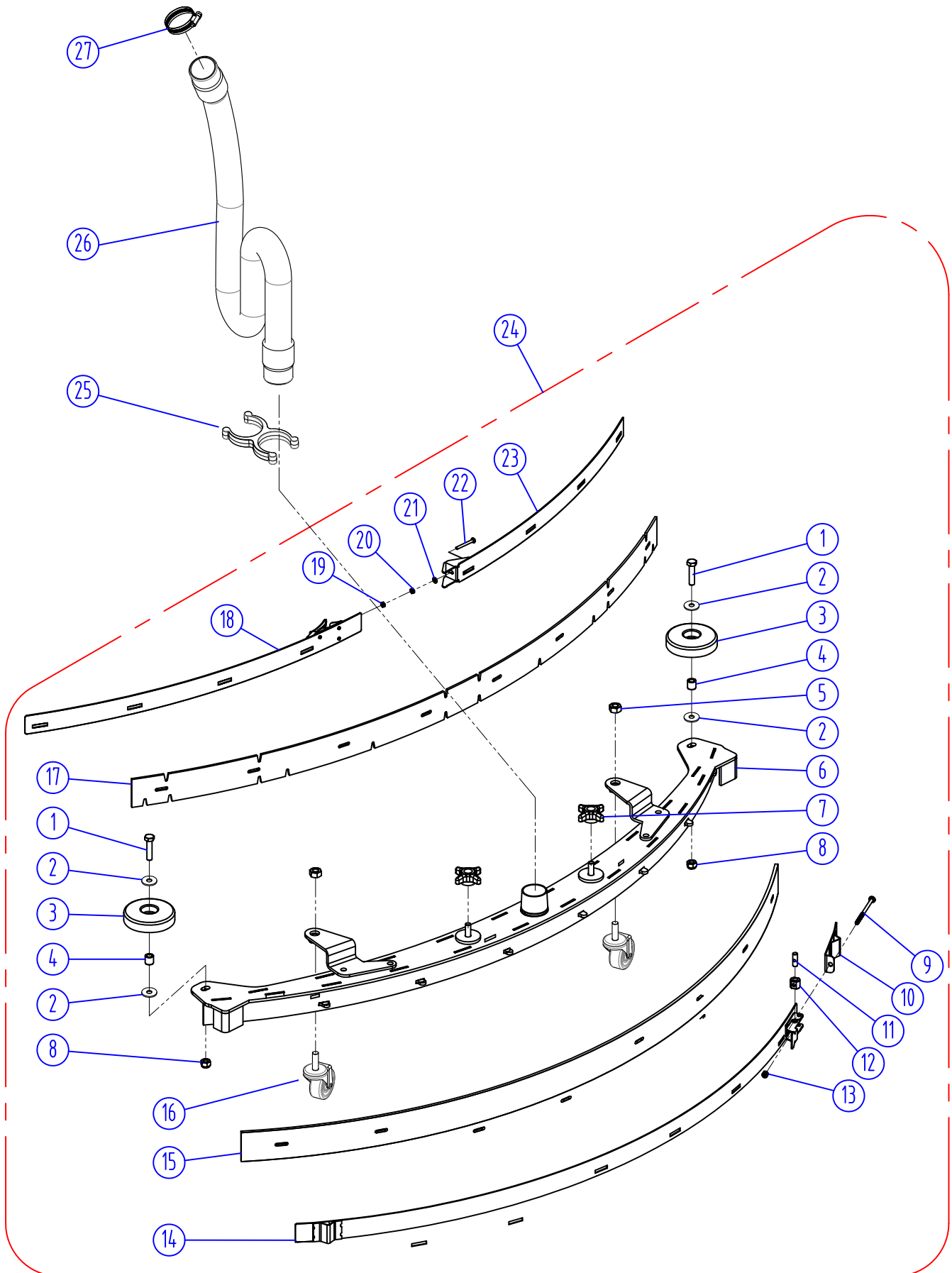
SQUEEGEE GROUP (44.5 INCH OPTIONAL)

PARTS LIST

SQUEEGEE GROUP (44.5 INCH OPTIONAL)

DIA NO.	PART NUMBER	SERIAL NUMBER	DESCRIPTION	NO. REQ'D
1	1021835		HEX BOLT,M8 X 35	2
2	1421824		FLAT WASHER,M8 X 24 X 2.0	2
3	8116009		PROTECTIVE WHEEL	2
4	8115404		BEARING, JOURNAL	2
5	1121008		HEX NUT,M10	2
6	8220501		SQUEEGEE HOUSING	1
7	8210518		STAR KNOB,M8	2
8	1123810		LOCK NUT,M8	2
9	1221575		SCREW,M5 X 75	1
10	8210525		SHORT CLAMP ASSEMBLY	1
11	8118624		SHAFT	1
12	8118623		SPACER	1
13	1123507		HEX NUT,M5	1
14	8220521		CLAMP ASSEMBLY, SQUEEGEE	1
15	8220513		SQUEEGEE BLADE, REAR, LINATEX	1
	8220523		SQUEEGEE BLADE, REAR, PU (OPTIONAL)	1
16	8118400		WHEEL, 2 INCH	2
17	8220514		SQUEEGEE BLADE, FRONT, LINATEX	1
	8220524		SQUEEGEE BLADE, FRONT, PU (OPTIONAL)	1
18	8220518		FRONT CLAMP,LEFT	1
19	1121403		HEX NUT,M4	1
20	1123406		LOCK NUT,M4	1
21	1421409		FLAT WASHER,M4 X 9 X 0.5	1
22	1211435		SCREW,M4 X 35	1
23	8220515		FRONT CLAMP,RIGHT	1
24	8220500		SQUEEGEE ASSEMBLY	1
25	8118109		HOLDER VACUUM HOSE	1
26	8118006		VACUUM HOSE	1
27	1962050		CLAMP	1

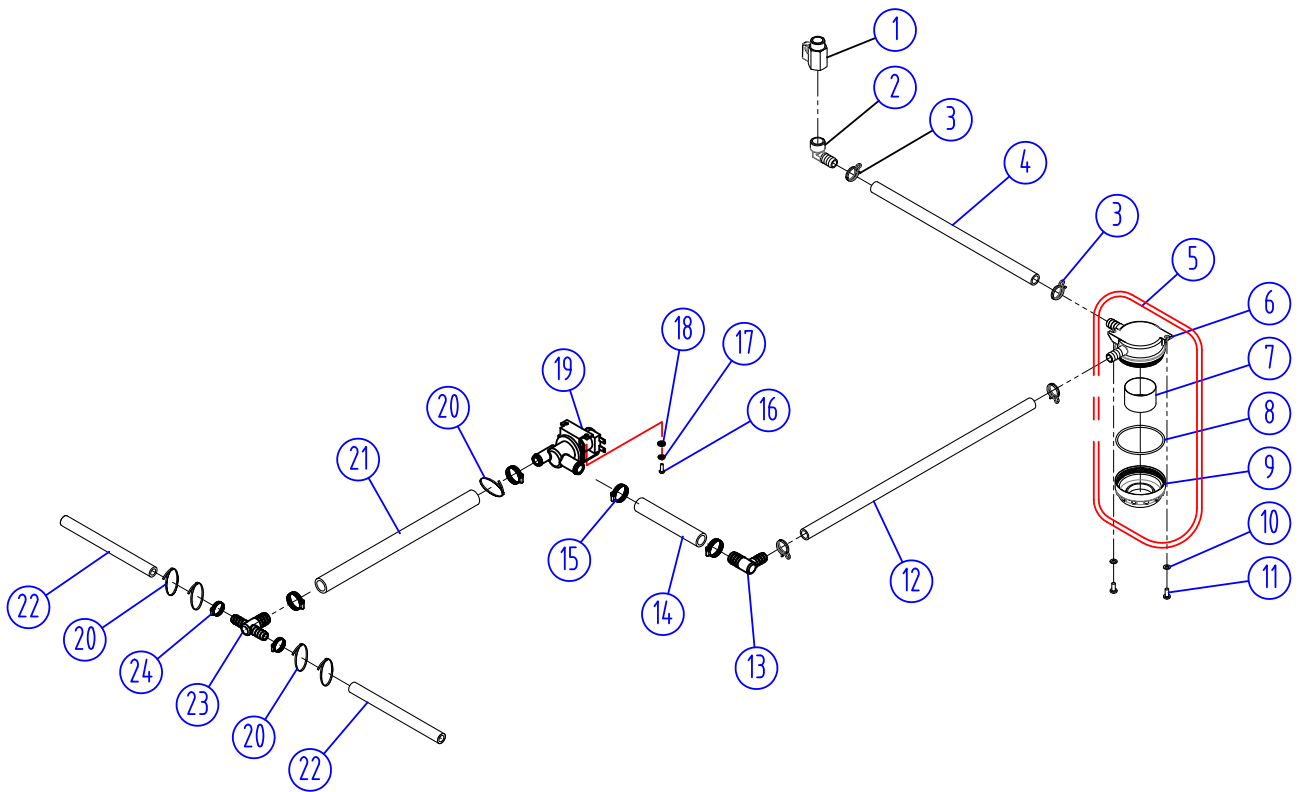
SOLUTION GROUP

PARTS LIST

SOLUTION GROUP

DIA NO.	PART NUMBER	SERIAL NUMBER	DESCRIPTION	NO. REQ'D
1	8119005		BALL VALVE, G1/2	1
2	8119007		ELBOW,G1/2	1
3	8119006		CLAMP	4
4	8230304		TUB NG, 0=12 X 365MM	1
5	8119100		F LTER ASSEMBLY	1
6	8119101		BASE, F LTER ASSEMBLY	1
7	8119103		SCREEN, F LTER, 70 MESH	1
	8119105		SCREEN, F LTER, 40 MESH (OPT ONAL)	1
8	1622063		"O" R NG	1
9	8119102		CAP, F LTER ASSEMBLY	1
10	1421510		FLAT WASHER,M5 X 10 X 1	2
11	1221512		SCREW ,M5 X 12	2
12	8230305		TUB NG, 0=12 X 560MM	1
13	8230309		ELBOW, TUB NG BARB	1
14	8230306		TUB NG, 0=16 X 120MM	1
15	1962025		CLAMP, 16-25mm	4
16	1221512		SCREW ,M5 X 12	2
17	1422513		LOCK WASHER,M5	2
18	1421512		FLAT WASHER,M5 X 10 X 1	2
19	8230122		SOLENO 0 VALVE,36V0C	1
20	1914300		T E, NYLON, 5X300	5
21	8230307		TUB NG, 0=16 X 300MM	1
22	8310903		TUB NG, 0=12 X 175MM	2
23	8230308		F TT NG, PLAST C, TEE	1
24	1962016		CLAMP, 10-16mm	2

CONTROL CONSOLE GROUP

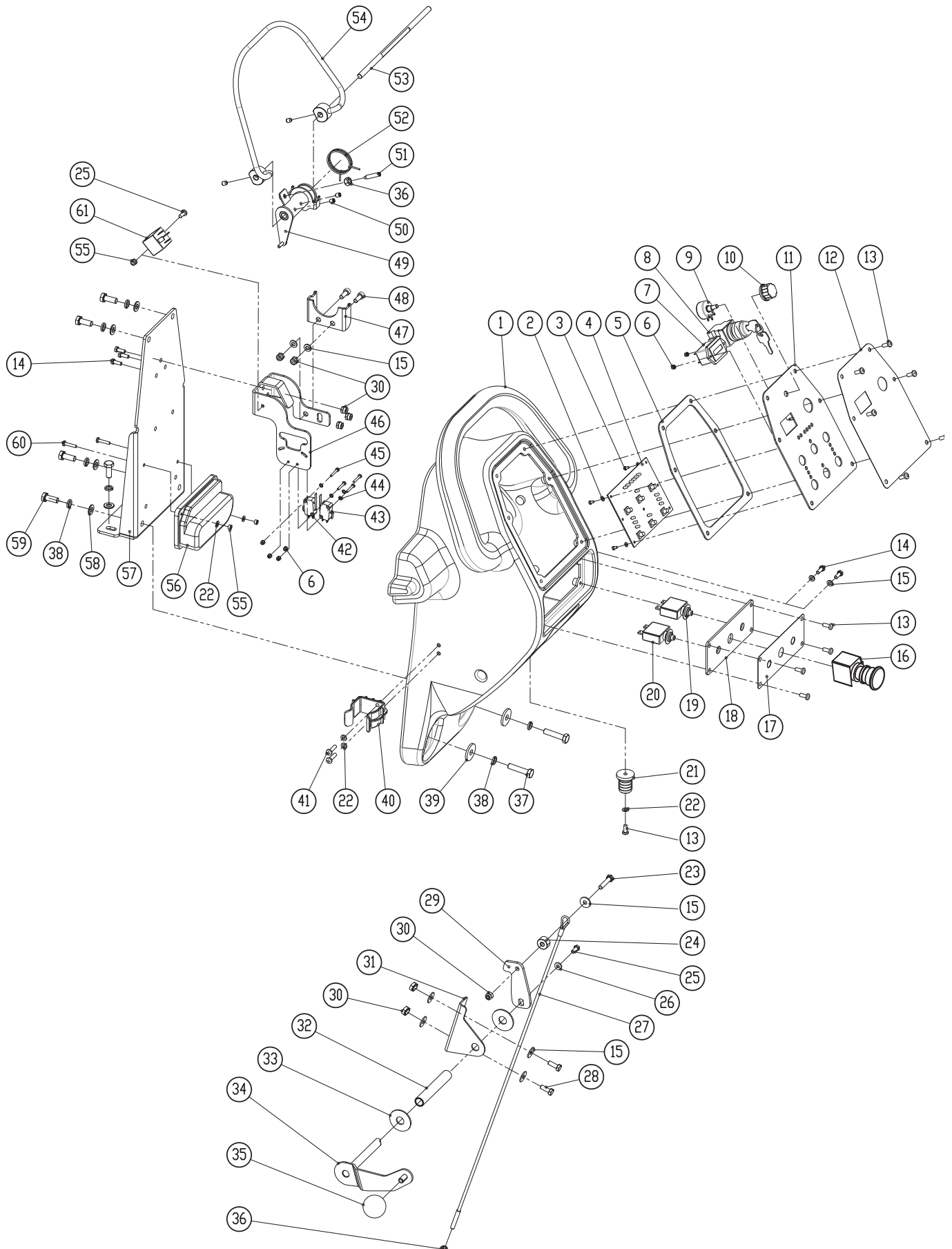

PARTS LIST

CONTROL CONSOLE GROUP

DIA NO.	PART NUMBER	SERIAL NUMBER	DESCRIPTION	NO. REQ'D
1	8134001		CONTROL CONSOLE HOUSING	1
2	1421307		FLAT WASHER M3×7×0.5	5
3	1221306		SCREW M3×6	5
4	8210401		PCB ASSEMBLY	1
5	8134015		GASKET	1
6	1123305		LOCK NUT M3	6
7	8114710		TIMER	1
8	8114709		KEY SWITCH	1
	8114752		KEY	1
9	8124717A		POTENTIOMETER, KIT	1
10	8124718		KNOB, POTENTIOMETER	1
11	8210410		CONTROL PANEL	1
12	8230710		CONTROL PANEL DECAL, i36BT	1
13	1221512		SCREW M5×12	12
14	1021616		HEX BOLT M6 X 16	5
15	1421618		PLAIN WASHER 6×18×1.6,SS	9
16	8310707		EMERGENCY STOP BUTTON	1
17	8144029		DECAL, EMERGENCY STOP	1
18	8134008		PLATE, EMERGENCY STOP MNTG	1
19	8114703		CIRCUIT BREAKER, 35A	1
20	8310740		CIRCUIT BREAKER, 5A	1
21	8114005		CONNECTOR	1
22	1421510		FLAT WASHER M5×10×1.0	5
23	1021630		HEX HEAD BOLT M6×30,SS	1
24	8014101		LIFTING ROPE SPACER	1
25	1021512		HEX HEAD BOLT M5×12,SS	2
26	1421515		FLAT WASHER M5×15×1.0	1
27	8210413		CABLE, SQGE LIFT	1
28	1021620		HEX HEAD BOLT, M6 ×20	2
29	8014012		BAFFLE	1
30	1123608		LOCK NUT M6	8
31	8134501		BRACKET	1
32	8134508		SLEEVE	1
33	1421132		FLAT WASHER 12×32×1.5	2
34	8014010		SQUEEGEE LIFTING HANDLE	1

PARTS LIST

CONTROL CONSOLE GROUP

DIA NO.	PART NUMBER	SERIAL NUMBER	DESCRIPTION	NO. REQ'D
35	8113104		BALL KNOB M8	1
36	1121605		HEX NUT M6	2
37	1021840		HEX BOLT M8×40	2
38	1422821		LOCK WASHER M8	8
39	1421828		FLAT WASHER M8×28×3	2
40	6210111		CLAMP, DRAIN HOSE	1
41	1221515		PH SCREW M5×15,SS	2
42	8124743		MICRO SWITCH	1
43	8114712		MICRO SWITCH	1
44	1434300		LOCK WASHER, TOOTH, M3	4
45	1021320		SCREW M3×20	4
46	8134022		BRACKET, SWITCH	1
47	8114402		BRACKET, SPRING	1
48	1521616		SCREW M6X16, HEX SCOKET	2
49	8114300		ACTUATOR	1
50	1534608		SET SCREW M6 ×8	4
51	1535630		SET SCREW M6 ×30	1
52	8114306		SPRING	1
53	8114101		SHAFT	1
54	8134300		LEVER, BAIL	1
55	1123507		LOCK NUT M5	3
56	8124501B		SPEED CONTROL BOARD	1
57	8134021		REAR PLATE, CONTROL CONSOLE	1
58	1421824		FLAT WASHER M8×24×2	6
59	1021820		HEX BOLT M8×20	6
60	1021535		SCREW, M5 × 35	2
61	8114707		RELAY, 40A	1

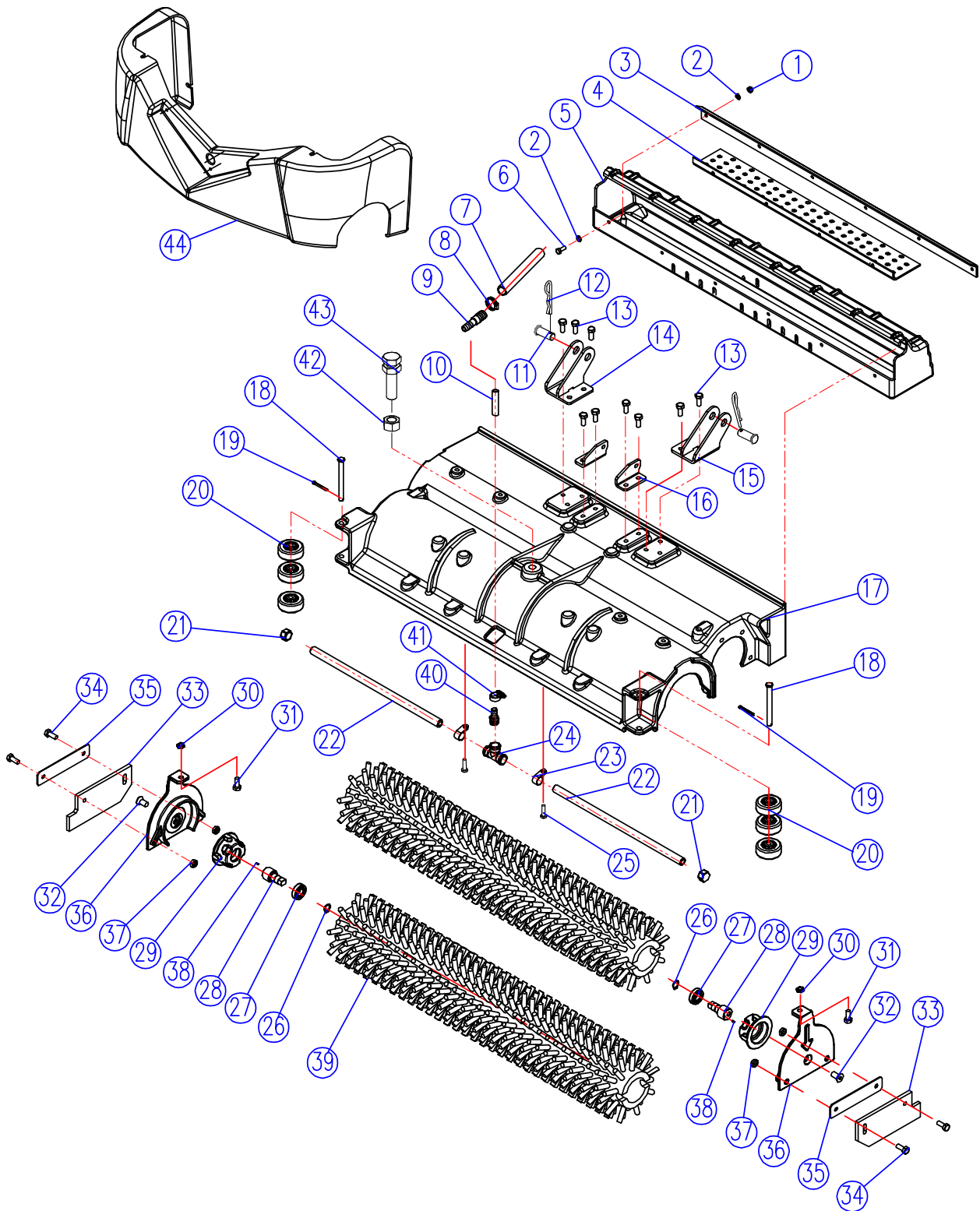
CYLINDRICAL SCRUB HEAD GROUP

PARTS LIST

CYLINDRICAL SCRUB HEAD GROUP

DIA NO.	PART NUMBER	SERIAL NUMBER	DESCRIPTION	NO. REQ'D
1	1123608		LOCK NUT,M6	6
2	1421612		FLAT WASHER,M6 X 12 X 1.6	12
3	8236019		LIP, HOPPER	1
4	8236020		STRIP, HOPPER	1
5	8236004		HOPPER	1
6	1021616		HEX BOLT,M6 X 16	6
7	8236038		TUBING,ID=16 X 450MM	1
8	1962025		CLAMP ,16-25MM	1
9	8701034		ELBOW, TUBING BARB	1
10	8236030		TUBING,ID=12 X 70MM	1
11	8230138	- for i36BT-CY	PIN	2
	8210807	-100161 for i36BT-CY	PIN(OLD)	2
12	8210309		PIN, COTTER	2
13	1021820		SCREW, M8 X 20	10
14	8230850	- for i36BT-CY	BRACKET, SCRUB HEAD LIFT, LEFT	1
	8236032	-100161 for i36BT-CY	BRACKET, SCRUB HEAD LIFT, LEFT(OLD)	1
15	8230840	- for i36BT-CY	BRACKET, SCRUB HEAD LIFT, RIGHT	1
	8236031	-100161 for i36BT-CY	BRACKET, SCRUB HEAD LIFT, RIGHT(OLD)	1
16	8236033		BRACKET, ACTUATOR MOUNTING	2
17	8236001		HOUSING CYLINDRICAL	1
18	8236011		PIN,M9.5X96	2
19	1645324		PIN, COTTER, M3.2 X 24	2
20	8236026		WHEEL,2"	6
21	8146303		END CAP,3/8"	2
22	8236035		PVC TUBING	2
23	8146305		PLASTIC CLAMP	4
24	8146301		TEE FITTING,3/8"	1
25	1221512		SCREW, M5 X 12	4
26	1436015		RING RETAINING, M15	2
27	1612602		BEARING, 6002LLU	2
28	8236009		SHAFT,IDLER	2
29	8236008		PLUG,IDLER,BRUSH	2
30	1121804		NUT,M8	2
31	1021840		SCREW, M8 X 40	2
32	1513020		COUNTERSUNK HEX SCREW,M10X20	2
33	8236013		SKIRT,CYLINDRICAL	2
34	1021816		SCREW, M8 X 16	4
35	8236014		CLAMP,SKIRT	2
36	8236002		DOOR,BRUSH	2
37	1123810		LOCK NUT,M8	4
38	1644206		PIN,M2.5X6	2
39	8236005		BRUSH,CYLINDRICAL	2
40	8013007		TUBING FITTING	1
41	1962016		CLAMP ,16MM	2
42	1111215		HEX NUT, M16	1
43	8210811		AJUSTMENT STUD, M16	1
44	8236003		FRONT COVER	1

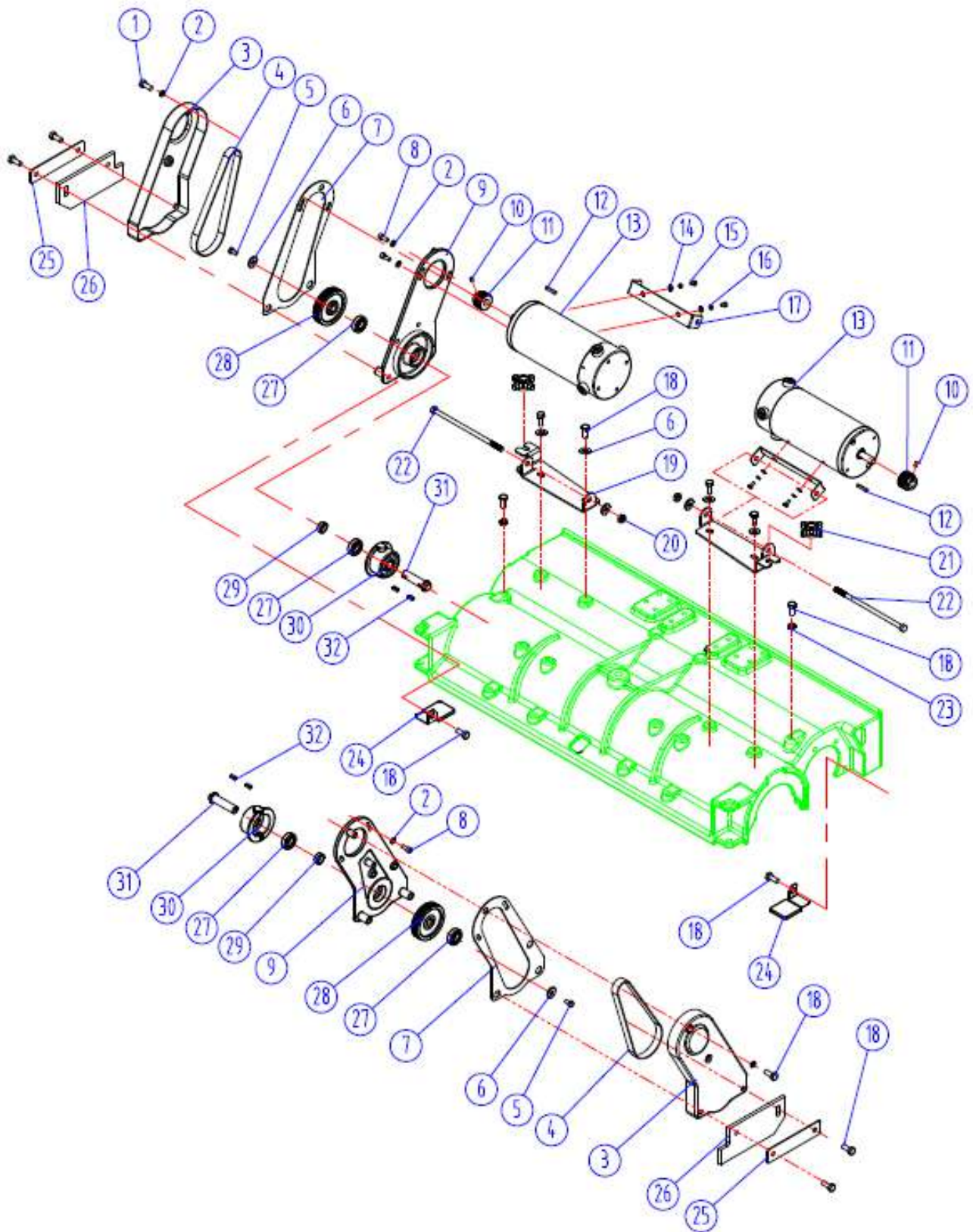
SOLUTION GROUP

PARTS LIST

SOLUTION GROUP

DIA NO.	PART NUMBER	SERIAL NUMBER	DESCRIPTION	NO. REQ'D
1	1521612		HEX SOCKET SCREW,M6 X 12	4
2	1421612		FLAT WASHER,M6 X 12 X 1.6	8
3	8236018		COVER,BELT	2
4	8236027		BELT,DRIVE,6PJ 508MM	2
5	1021816		HEX BOLT,M8 X 16	2
6	1421824		FLAT WASHER,M8 X 24 X 2	8
7	8236029		GASKET,BELT	2
8	1521616		HEX SOCKET SCREW,M6 X 16	4
9	8236017		BRACKET, MOTOR MOUNTING	2
10	1534508		SCREW,M5 X 8	4
11	8236012		DRIVING PULLEY,6PJ	2
12	8236023		KEY,4 X 4 X 25	2
13	8236028A		KIT,MOTOR,36VDC,0.75HP	2
14	1421511		FLAT WASHER,M5 X 12 X 1	4
15	1021512		HEX BOLT,M5 X 12	4
16	1422513		WASHER,LOCK,M5 X 12 X 1	4
17	8236015		ANGLE BRACKET, MOTOR	2
18	1021820		HEX BOLT,M8 X 20	18
19	8236016		BRACKET, MOTOR	2
20	1123810		LOCK NUT,M8	2
21	8118003		STAR KNOB,M8	2
22	8236034		HEX BOLT,M8 X 185	2
23	1121804		NUT,M8	2
24	8236021		DEFLECTOR,WATER	2
25	8236014		CLAMP,SKIRT	4
26	8236013		SKIRT,CYLINDRICAL	4
27	1612602		BEARING, 6002LLU	4
28	8236007		DRIVEN PULLEY,6PJ	2
29	8236024		BUSHING	2
30	8236025		PLUG, DRIVE,BRUSH	2
31	8236010		SHAFT	2
32	1655015		KEY,5 X 5 X 15	4

WEAR & TEAR PARTS LIST

DIA NO	PART NUMBER	DESCRIPTION	NO REQ'D
1	8230116	WHEEL, 12 INCH	2
2	8116009	PROTECTIVE WHEEL	3
3	8230119	CASTER, 5 INCH	2
4	8210513	SQUEEGEE BLADE, FRONT, LINATEX	1
5	8210514	SQUEEGEE BLADE, REAR, LINATEX	1
6	9050016	16" BRUSH	2
7	9040016	16" PAD HOLDER	2
8	8236005	CYLINDRICAL BRUSH	2
9	8236013	CYLINDRICAL SKIRT	4

WIRING DIRGRAM

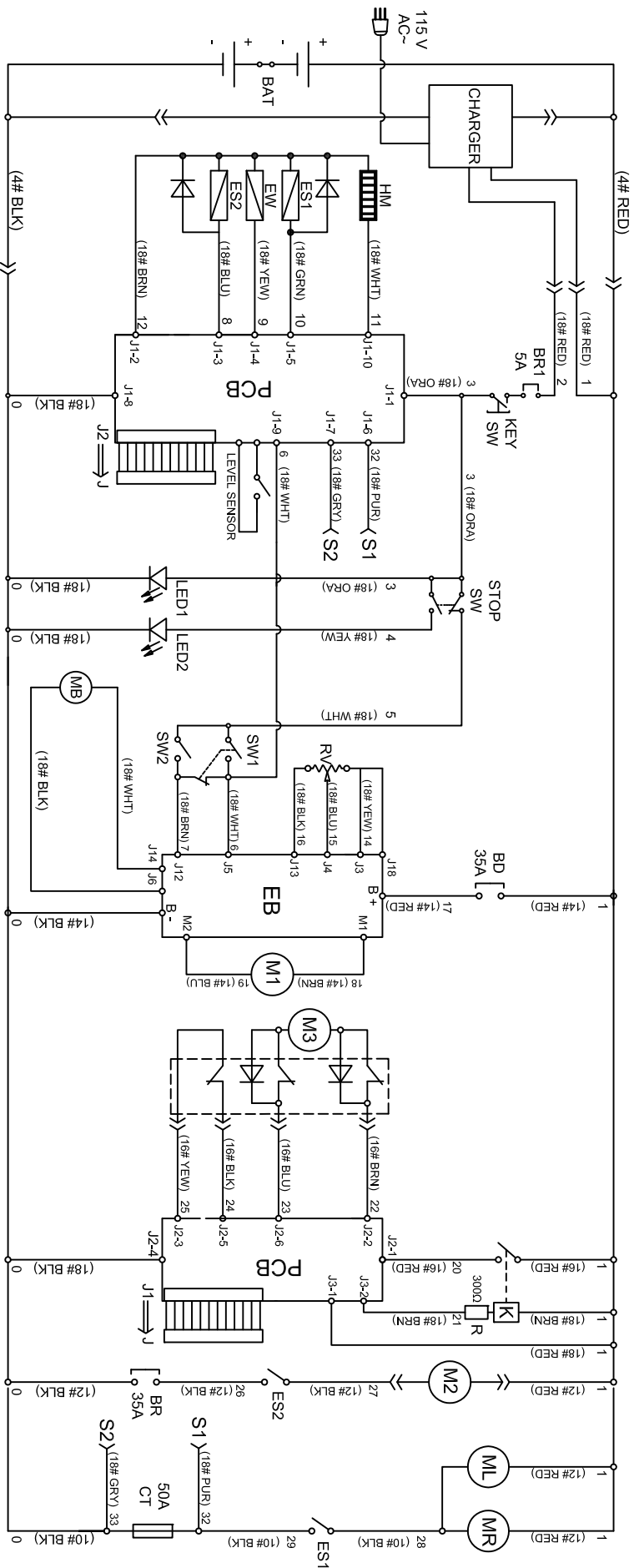

- BAT:6X6V Batteries
- CHARGER:On board charge
- KEY SW: Main power key switch
- HM:Hour meter
- ES1:Brush motor solenoid switch
- EW:Solution solenoid valve switch
- ES2:Vacuum motor solenoid switch
- PCB:Fuction electronic board
- STOP SW:Emergency stop switch
- MB:Electromagnetic brake
- LED1:Running lights
- LED2:Emergency stop lights
- MR:Brush motor ,right

- BD: Driver motor circuit breaker
- RV: Speed potentiometer
- SW1: Control switch,forward
- SW2: Control switch,backward
- EB:Speed control board
- M1:Traction motor
- K:Key
- M3:Scrub hend lifting motor
- BR:Vacuum motor circuit: breaker
- M2:Vacuum motor
- ML:Brush motor, left
- CT:Current transformer
- BR1: Brake circuit breaker

CERTIFICATE OF QUALIFIED

MODEL: _____

SERIAL NO.: _____

INSPECTOR: _____

DATE: _____

ICE Company Limited

TEL: (+86) 769 8186 9000

FAX: (+86) 769 8186 3000